

I.D. - I.D.

Reduces O.D. pipe of different sizes.

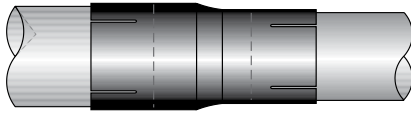

-- I.D. --	-- I.D. --	Length		Part	
in	mm	in	mm	Number	
2.50	64	2.00	51	6.00 152	P207382
2.75	70	2.50	64	6.00 152	P207385
3.00	76	2.50	64	6.00 152	P206313
		2.75	70	6.00 152	P207386
3.50	89	3.00	76	6.00 152	P206314
4.00	102	3.00	76	6.00 152	P206315
		3.50	89	8.00 203	P206316
5.00	127	4.00	102	6.00 152	P206317
6.00	152	5.00	127	8.00 203	P206318



I.D. - O.D.

Reduces larger O.D. pipe to smaller I.D. pipe. Also used as muffler bushing or manifold outlet.



-- I.D. --	-- O.D. --	Length		Part	
in	mm	in	mm	Number	
2.50	64	2.00	51	6.00 152	P207397
3.00	76	2.50	64	6.00 152	P206319
		2.75	70	6.00 152	P207401
3.50	89	3.00	76	6.00 152	P206320
4.00	102	3.00	76	6.00 152	P206321
		3.50	89	6.00 152	P206322
4.50	114	4.00	102	6.00 152	J190046
5.00	127	4.00	102	6.00 152	P206323
6.00	152	5.00	127	6.00 152	P207402



O.D. - I.D.

Reduces larger I.D. pipe to smaller O.D. pipe.

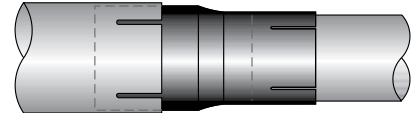

-- O.D. --	-- I.D. --	Length		Part	
in	mm	in	mm	Number	
2.50	64	2.00	51	6.00 152	P207389
2.50	64	2.25	57	4.00 102	J008942
3.00	76	2.50	64	6.00 152	P206324
3.50	89	3.00	76	6.00 152	P206325
4.00	102	3.00	76	6.00 152	P206326
		3.50	89	6.00 152	P206327
4.50	114	4.00	102	6.00 152	J190041
5.00	127	4.00	102	6.00 152	P206328
6.00	152	5.00	127	6.00 152	P207394



Connectors

I.D. - I.D.

Connects O.D. pipes of the same size.



--- I.D. ---	-- Length --		Part	
in	mm	in	mm	Number
2.00	51	6.00	152	P207405
2.50	64	6.00	152	P206371
3.00	76	6.00	152	P206372
3.50	89	6.00	152	P206373
4.00	102	6.00	152	P206374
5.00	127	6.00	152	P206375
6.00	152	6.00	152	P207408

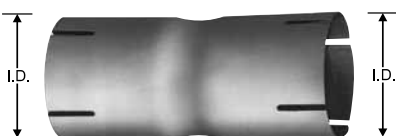

I.D. - O.D.

Connects O.D. and I.D. pipes of the same size.

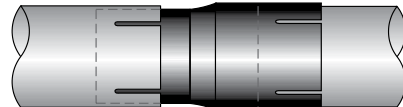

I.D.-O.D.	-- Length --		Part	
in	mm	in	mm	Number
2.00	51	6.00	152	P207411
2.50	64	6.00	152	P206366
2.75	70	6.00	152	P207413
3.00	76	6.00	152	P206367
3.50	89	6.00	152	P206368
4.00	102	8.00	203	P206369
5.00	127	8.00	203	P206370
6.00	152	6.00	152	P207414



O.D. - O.D.

Connects I.D. pipes of the same size. Also used on manifold outlet. Connector has tube stop.

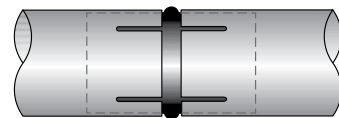

O.D.-O.D.	-- Length --		Part	
in	mm	in	mm	Number
2.50	64	6.00	152	P206361
3.00	76	6.00	152	P206362
3.50	89	6.00	152	P206363
4.00	102	8.00	203	P206364
5.00	127	8.00	203	P206365



O.D. - O.D.

Reduces I.D. pipe of different sizes.

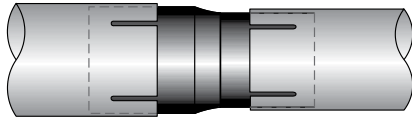

-- O.D. -- in mm	-- O.D. -- in mm	Length in mm	Part Number
3.00 76	2.50 64	6.00 152	J190042
3.50 89	3.00 76	6.00 152	J190044
4.00 102	3.00 76	6.00 152	J009648
	3.50 89	6.00 152	J190045
5.00 127	4.00 102	8.00 203	J009649
6.00 152	5.00 127	8.00 203	J009650



Tilt Cab Ball & Cone Connectors

- 16 gauge aluminized steel construction



Ball Connector
P205976 - 4" Pipe I.D. Diameter
P206300 - 5" Pipe I.D. Diameter



Cone Connector
P205979 - 4" Pipe O.D. Diameter
P206299 - 5" Pipe O.D. Diameter

Standard "Y" Adapter Pipe

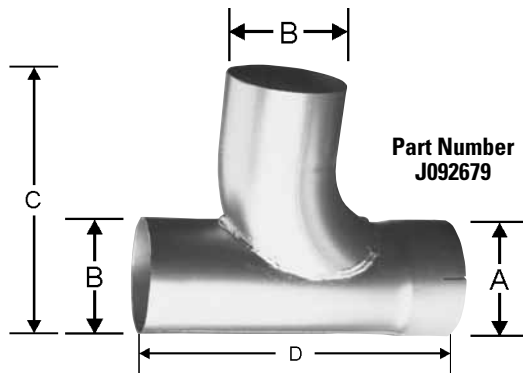

- A (I.D.) - in mm	- B (O.D.) - in mm	----- C ----- in mm	----- D ----- in mm	Part Number
4.00 102	4.00 102	9.00 229	14.00 356	J092679
5.00 127	5.00 127	10.50 267	15.00 381	J092689

Splitter Tee Adapter

- Converts single exhaust pipe to dual exhaust system
- 16 gauge aluminized steel

(A) in mm	(B) in mm	Truck ID (C) in mm	Leg OD (D) in mm	Part Number
17.50 445	12.00 305	4.00 102	4.00 102	P206297
26.00 660	14.00 356	5.00 127	5.00 127	P206298

Band width 1.5" (38mm)

