



Industrial Filters · Accumulators

Inline Filters

40 FLE 0020(C) - 0270(C)

40 FLEN 0160 - 1000

100 FLE 0020(C) - 0120(C)

100 FLEN 0160 - 0630



Filters for Inline installation

Designed for offline filtration

*Installation of environmental friendly
EPOPore Filter Elements with reusable
core (central tube)*

Large filter area

*Optimised flow characteristics
by 3D - computer aided design*

Low pressure drop

*Special high efficient
filter media*

Operating pressure: 40/100 bar

Connection up to SAE 4"



Quality assured!

Spare Parts List

100 FLE 0020(C) - 0120(C)
100 FLEN 0160 - 0630

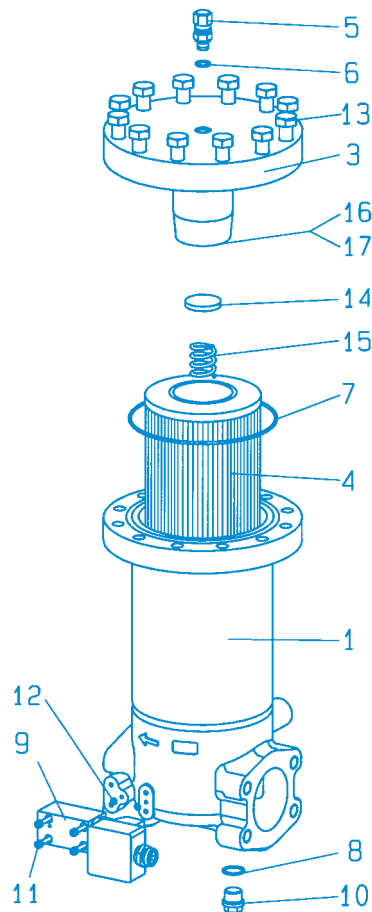

			Size FLE FLEN	0020(C) 0160	0030(C) 0250	0045(C)	0060(C) 0400	0095(C) 0630	00120(C)
Part	Quantity	Designation	Material	please indicate ordering information „Filter“					
1	1	Filter housing	various	please indicate ordering information „Filter“					
3	1	Filter head	various	please indicate ordering information „Filter“					
4	1	Filter element	various	please indicate ordering information „Filter Element“					
4.1	1	Core	St	only for ECOPore® „C“ indicate ordering information „Filter“					
5	1	Vent valve	Bronze	Part No. 848					
6	1	Seal ring	Soft iron	please indicate ordering information „Seal Kit“					
7	1	O-ring	Buna N	please indicate ordering information „Seal Kit“					
8	1	Seal ring	Soft iron	please indicate ordering information „Seal Kit“					
9	1	Maintenance indicator	various	please indicate ordering information „Maintenance indicator“					
10	1	Plug	St	Part No. 789					
11	4	Hexagon head cap screw	8.8	Part No. 633					
12	2	O-ring	Buna N	please indicate ordering information „Seal Kit“					
13	8	Hexagon screw	8.8	Part No. 602			-		
	12			-			Part No. 603		
14	1	Valve disk	various	please indicate ordering information „Filter“					
15	1	Valve disk	1.0600						
16	1	Valve spring	St						
17	1	Retaining ring	Spring steel						

Quality and Standardisation

The development, manufacture and assembly of EPE-industrial filters and filter elements is carried out within the framework of a certified quality management system in accordance with DIN EN ISO 9001.

The stability calculation and testing of the filters proceeds according to existing pressure vessel regulations, as well as in accordance with national and international norms.

Certification of the filters by accredited institutions (for example TÜV, GL, LRS, LRIS, ABS, BV, DNV, DRIRE, UDT etc.) is available on request.

Dimensions

40 FLE 0020(C) - 0120(C)
40 FLEN 0160 - 0630

40 FLE 0145(C) - 0270 (C)
40 FLEN 1000

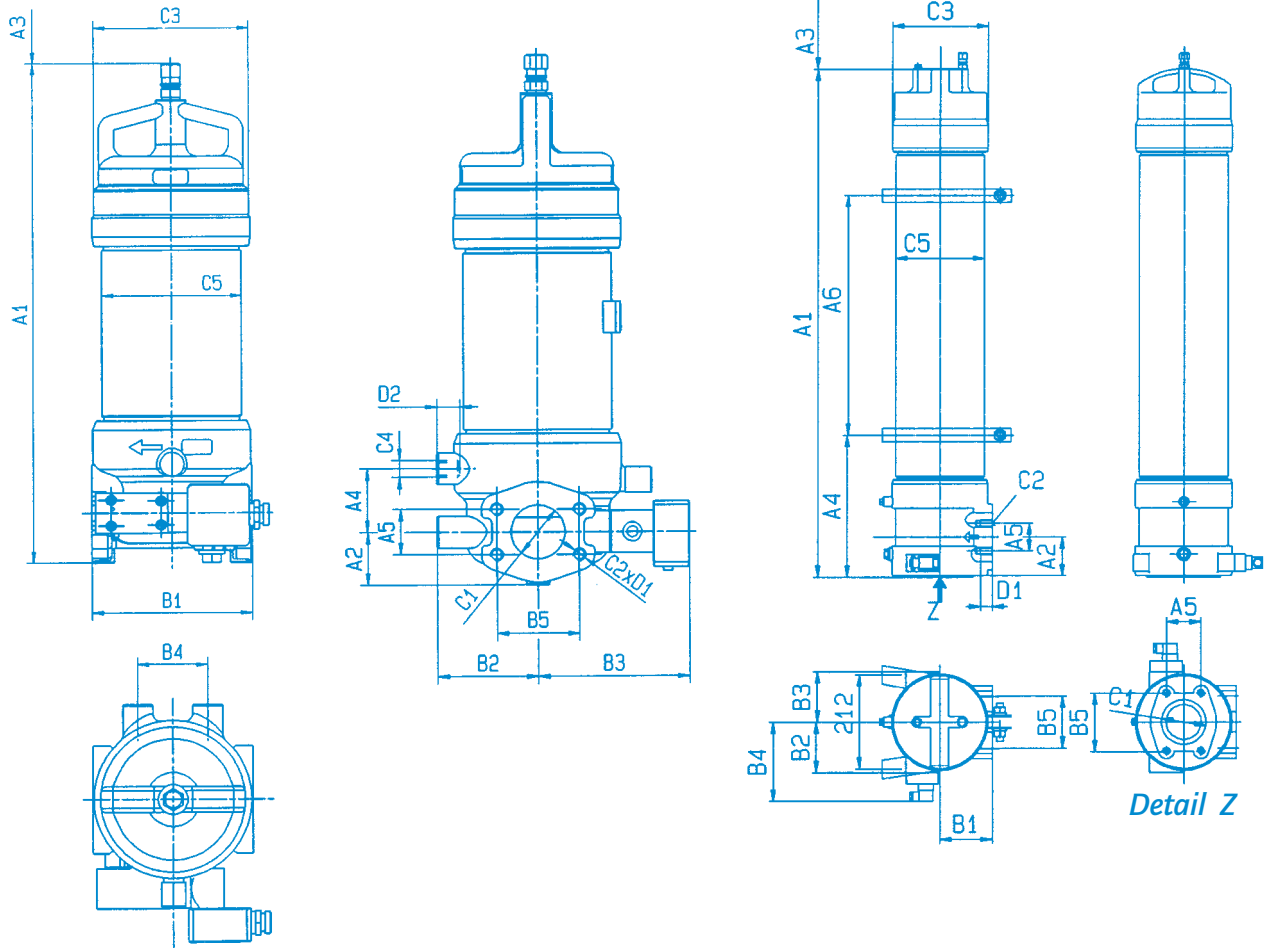

Filter housing for filter element in accordance with EPE standard

Type	Capacity in l	Weight in kg ¹⁾	A 1	A 2	A 3 ²⁾	A 4	A 5	A 6	B 1	B 2	B 3	B 4	B 5	C 1	C 2	C 3	C 4	C 5	D 1	D 2
40 FLE 0020 (C)	1,4	12	411		160									SAE2"						
40 FLE 0030 (C)	2,7	13,2	501	49,5	250	60	42,9		160	95	143	70	77,8	3000psi DN50	M12	Ø158		Ø140	20	
40 FLE 0045 (C)	4,8	19	651		400												M16			22
40 FLE 0060 (C)	4	19,5	543		250									SAE3"						
40 FLE 0095 (C)	7,1	21,9	693	61,5	400	70	61,9		195	105	155	90	106,4	3000psi DN80		Ø188		Ø170	30	
40 FLE 0120 (C)	14	27,4	1050		750										M16					
40 FLE 0145 (C)	12	50	553		400	260		65						SAE4"						
40 FLE 0200 (C)	22	60	911	90	758		77,8	310	118	113	113	183	130	3000psi DN100		Ø216	-	Ø200	26	-
40 FLE 0270 (C)	28	70	1145		992	320		540												

Filter housing for filter element in accordance with DIN 24550

Type	Capacity in l	Weight in kg ¹⁾	A 1	A 2	A 3 ²⁾	A 4	A 5	A 6	B 1	B 2	B 3	B 4	B 5	C 1	C 2	C 3	C 4	C 5	D 1	D 2
40 FLEN0160	1,4	12	411		160									SAE2"						
40 FLEN0250	2,7	13,2	501	49,5	250	60	42,9		160	95	143	70	77,8	SAE3000psi DN 50	M12	Ø 158		Ø 140	20	
40 FLEN0400	4	19,5	543		250									SAE3"						22
40 FLEN0630	7,1	21,9	693	61,5	400	70	61,9		195	105	155	90	106,4	SAE3000psi DN 80		Ø 188		Ø 170	30	
40 FLEN1000	12	50	553	90	400	260	77,8	65	118	113	113	183	130	SAE4" SAE3000psi DN100	M16	Ø 216	-	Ø 200	26	-

¹⁾ = Weight including standard filter element and maintenance indicator

²⁾ = Construction dimension for filter element change

Inline Filter

40/100 FLE 0020(C) - 0270(C)
 40 FLEN 0160 - 1000
 100 FLE 0020(C) - 0120(C)
 100 FLEN 0250 - 0630
 Operating pressure 40/100 bar
 Operating temperature -10°C bis +100°C
 Connection up to SAE 4"

Application

Filtration of pressurised liquids and lubricants.

Filtration of liquids and gases.
 Direct installation in pipelines. Direct wear protection of subsequent components and systems.

Offline filtration with high service time.

Design:

40 FLE 0020 (C) - 0270 (C) and
 40 FLEN 0160 - 1000

Modular design constructed out of three parts including filter bowl with inlet and outlet, filter body and threaded filter head.

100 FLE 0020 (C) - 0120 (C) and
 100 FLEN 0160 - 0630

Two part design out of filter housing with inlet and outlet and flange mounted filter cover.

Filter Element

Pleated design with optimised pleat density and various filter media. The filter element is the most important component of the filter in view of prolonged life and wear protection of the system.

Oil cleanliness, the initial pressure drop and the dirt holding capacity are the most important criteria for selection.

For further detailed information please refer our "Filter Elements" brochure.

A proper filter selection is enabled by our "EPE - FILTERSELECT" software.

Accessories

Maintenance Indicators

For monitoring the filter element's contamination status, optical and optical/electrical indicators, with one or two switching points are available.

Bypass Valve

To protect the filter element during start up and over pressurisation due to clogging.

Vent valve

For removing the air from the filter during starting and for safe de-pressurisation.

Performance Characteristics

Oil Viscosity 30 mm²/s
 Specific gravity: < 0,9 kg/dm³

Pressure drop curves for filter assemblies
 recommended initial Δp for filter selection

40 FLE/FLEN: 0,8 bar

100 FLE/FLEN: 1,5 bar

recommended max. velocity

40 FLE/FLEN: 3,5 m/s

100 FLE/FLEN: 4,0 m/s

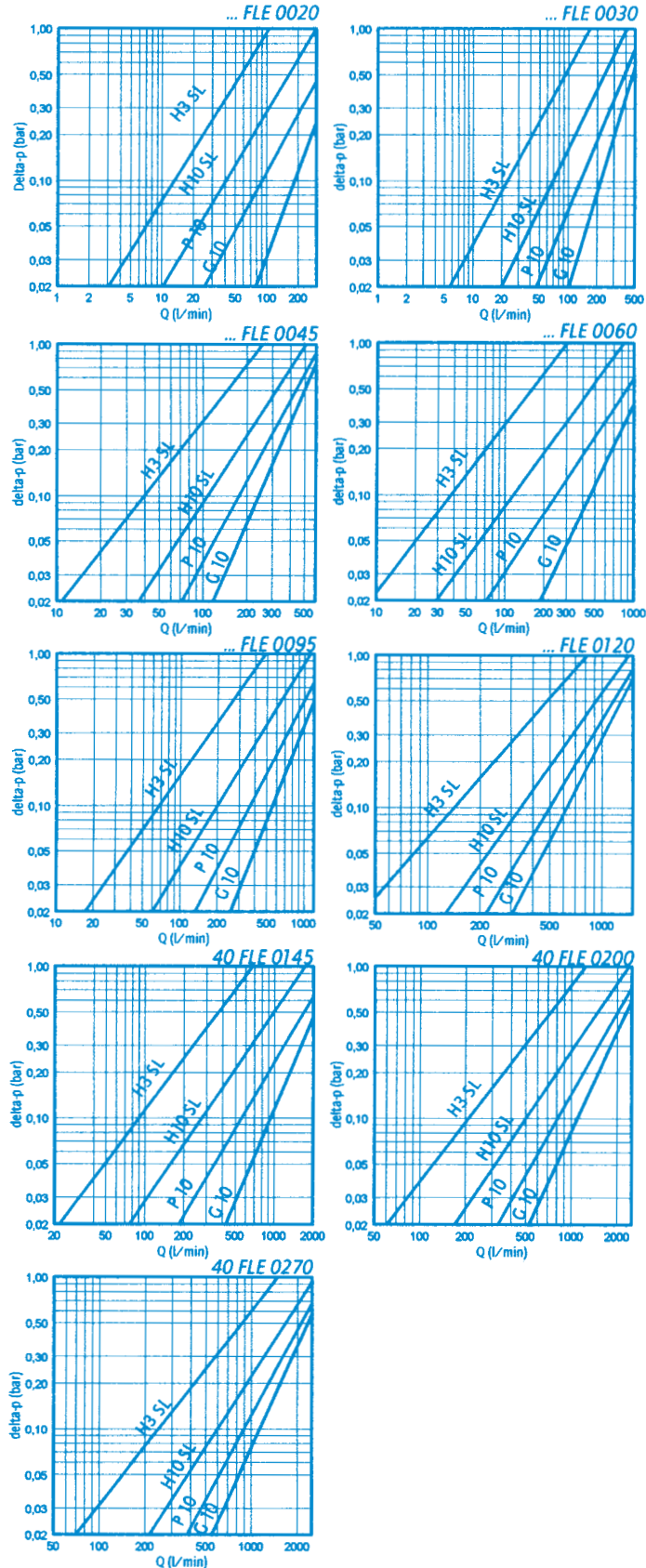

Ordering code

Identification of filter size:
Using the computer programme „EPE-FILTERSELECT“ or the performance characteristic lines in this brochure.

Special models are available on request.

Type	Magnet	Maintenance Indicator	Connection	Material
FLE= Inline filter with filter element according to EPE Standard FLEN= Inline filter with filter element according to DIN 24550	O= without	O...without 40 FLE 0145 - 0270, 40 FLEN 1000 B...=Maintenance indicator optical C...=Maintenance indicator optical/ electrical with electric plug D...=Maintenance indicator with three 24V diodes and two switch points 40/100 FLE 0020 - 0120, 40/100 FLEN 0160 - 0630 A...=Maintenance indicator optical B...=Maintenance indicator optical/ electrical with electric plug C...=Maintenance indicator with three 24V diodes two switch points Standard switch pressure: 2,5 u. 5,0 bar For extensive ordering information and technical data refer to on brochure "Maintenance indicator"	SO= SAE-Flange	O=standard

Filter → 40 FLE 0270 H10SL - 0 00 - 0 0 B2,5 - SO P 0 0

Seal Kit → D40 FLE 0270 - B - SO P 0

Pressure	Size	Filtration Grade	Diff. Pressure	Element Model	Bypass Valve	Dichtung	Erg. Angaben
40 bar 100 bar	40/100 FLE 0020(C) 0030(C) 0045(C) 0060(C) 0095(C) 0120(C) only for 40 FLE 0145(C) 0200(C) 0270(C) only for 40/100 FLEN 0160 0250 0400 0630 1000 (C)=coreless filter element	Nominal filter fineness in µm G = stainless steel wire mesh cleanable G10, G25, G40, G60, G80, G100 VS = nonwoven, not cleanable VS25, VS40, VS60 P = Paper, not cleanable P5, P10, P25 Absolute filter fineness (ISO 4572) in µm H...SL= Microglass, not cleanable H1SL, H3SL, H6SL, H10SL, H20SL AS = Microglass, water-absorbent, not cleanable AS1, AS3, AS6, AS10, AS20	Max. allowable differential pressure of the filter element A= 30 bar O= 15 bar only for 0145 0200 0270	O...= Standard-adhesive T=100°C E...= Special-adhesive T=160°C ...O= Standard material ...Z= Free of zinc	0= without 7= 3,5 bar	P= Buna N V= Viton E= Ethylene-propylene N= Neoprene	O= without 1= "A" Indicator for 40 FLE 0145(C)-0270(C) 2= "B" Indicator for 40 FLE 0145(C)-0270(C) 5= silicon free B= fixing clamp E= vent valve Z= documentation 5= silicon free Z= documentation

Filter Element → 1. 0270 H10SL - 0 00 - 0 - P

Maintenance Indicator

The maintenance indicator monitors the degree of clogging of the filter elements. They are available as optical or optical/electrical displays. See "Maintenance Indicator" brochure for technical data.

A...optical B...optical	B...optical/electrical C...optical/electrical	C/D...optical/electrical with three 24 V diodes and two switching points
Ordering information A2,5 = F2,5 A0 00 OOP* B2,5 = F2,5 A0 00 OOP*	Ordering information B2,5 = F2,5 GW 02 OOP* C2,5 = F2,5 GW 02 OOP*	Ordering information C2,5 = R2,5 GW 09 ZOP* D2,5 = R2,5 GW 09 ZOP*
	Switching Symbol	Switching Symbol

Filter Switching Symbol

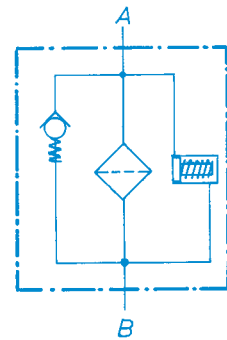

*P = Buna N; V = Viton, E = Ethylene Propylene, N = Neoprene possible

Dimensions

100 FLE 0020(C) - 0120(C)
100 FLEN 0160 - 0630

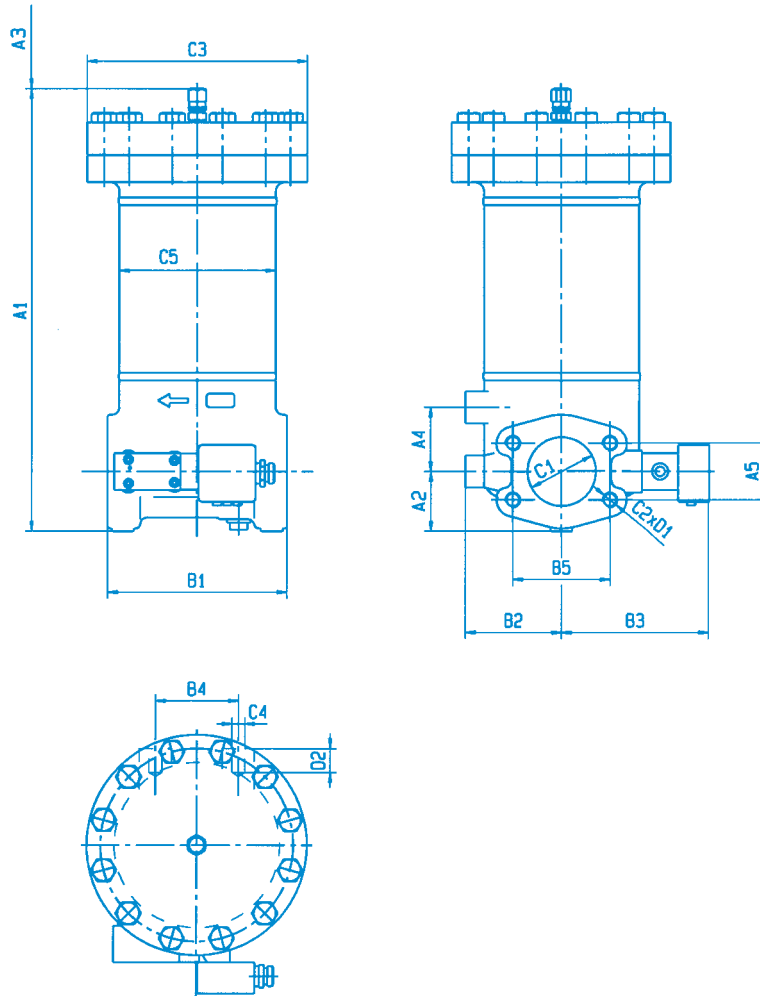

Filter housing for filter element in accordance with EPE standard

Type	Capacity in l	Weight in kg ¹⁾	A 1	A 2	A 3 ²⁾	A 4	A 5	B 1	B 2	B 3	B 4	B 5	C 1	C 2	C 3	C 4	C 5	D 1	D 2
100 FLE 0020(C)	2,1	22,4	351	50	160	60	42,9	160	95	144	70	77,8	SAE2"	M 12	Ø200	M 16	Ø140	20	22
100 FLE 0030(C)	3,2	28	441		250								3000psi						
100 FLE 0045(C)	5,1	29	591	65	400	70	61,9	195	105	158	90	106,4	DN50	M 16	Ø240	Ø170	30	30	
100 FLE 0060(C)		34	482		250								SAE3"						
100 FLE 0095(C)	7,8	38,3	632	75	400	70	61,9	195	105	158	90	106,4	3000psi	M 16	Ø240	Ø170	30	30	
100 FLE 0120(C)	14,3	49,2	989		750								DN80						

Filter housing for filter element in accordance with DIN 24550

Type	Capacity in l	Weight in kg ¹⁾	A 1	A 2	A 3 ²⁾	A 4	A 5	B 1	B 2	B 3	B 4	B 5	C 1	C 2	C 3	C 4	C 5	D 1	D 2
100 FLEN 0160	2,1	22,4	351	50	160	60	42,9	160	95	144	70	77,8	SAE2"	M 12	Ø200	M 16	Ø140	20	22
100 FLEN 0250	3,2	28	441		250								3000psi						
100 FLEN 0400	5,1	34	482	65	400	70	61,9	195	105	158	90	106,4	DN50	M 16	Ø240	Ø170	30	30	
100 FLEN 0630	7,8	38,3	632		400								SAE3"						

¹⁾ = Weight including standard filter element and maintenance indicator

²⁾ = Construction dimension for filter element change

Spare Parts List

40 FLE 0020(C) - 0120(C)
40 FLEN 0160 - 0630

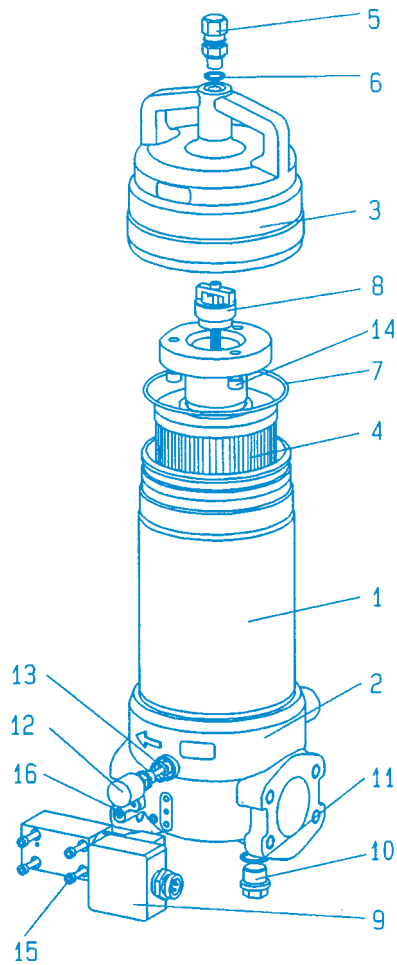

40 FLE 0145(C) - 0270(C)
40 FLEN 1000

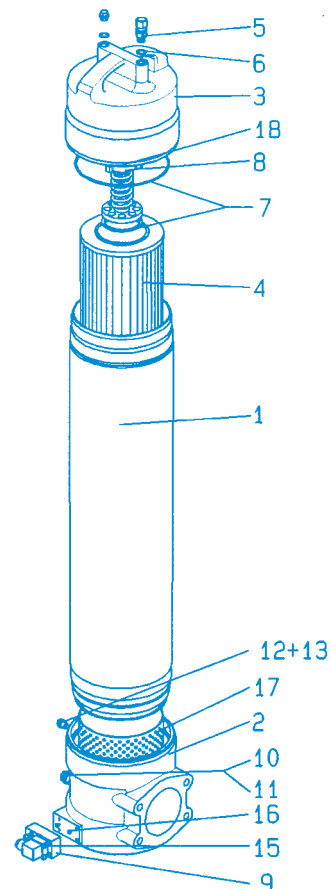

Port	Quantity	Designation	Material	Size FLE FLEN	0020(C) 0160	0030(C) 0250	0045(C)	0060(C) 0400	0095(C) 0630	00120(C)	0145(C) 1000	0200(C)	0270(C)
1	1	Filter housing	various										
2	1	Filter lower part	various										
3	1	Filter head	various										
4	1	Filter element	various										
4.1	1	Core	St										
5	1	Vent valve	Bronze										
6	1	Seal ring	Soft iron										
7	3	O-ring	Buna N										
8	1	Bypass-valve	various										
9	1	Maintenance indicator	various										
10	1	Plug	St										
11	1	Seal ring	Soft iron										
12	1	Locking screw	various										
13	1	Seal ring	Soft iron										
14	3	Hexagon head cap screw	8.8			Part No. 637			Part No. 652				–
15	4	Hexagon head cap screw	8.8							Part No. 633			
16	2	O-ring	Buna N										
17	1	Protecting basket	St										Part No. 4736
18	1	Plug	St										Part No. 795



Industrial Filters · Accumulators

Installation, Starting and Maintenance

Installation

Verify operating pressure with name plate information.

Mount the filter assembly using mounting holes on the filter housing (Part 1) considering flow direction (direction arrows) and servicing height required for cleaning/replacing elements.

Switch of system pump. Remove dust caps from filter inlet and outlet, fit filter into the pipe avoiding tension stress on existing pipework.

Connection of electrical maintenance indicator

Connect indicator using the three wired cable.

Please verify electrical ratings on the indicators (Part 9) name plate.

- | | |
|------------|----------------------------------|
| 1. Closer | 1 (black) + 3 (blue) |
| 2. Opener | 1 (black) + 2 (brown) |
| 3. Changer | 1 (black) + 2 (brown) + 3 (blue) |

Starting

Switch on service pump.

Ventilate filter by opening the vent valve (Part 5), close when operating liquid appears.

Maintenance

The filter element is clogged and must be changed or cleaned when at operation temperature the red pointer on the maintenance indicator (Part 9) is hard against the plastic cap and / or the switching process on the electrical indicator is triggered.

Filter element service

Switch of system pump.

Open vent valve (part 5) and depressurize system.

Open plug (part 10) and drain contaminated oil from filter housing.

Unscrew filter upper part / filter cover (part 3) and remove filter element from housing turning slightly off its locator in the filter lower part.

Screw in plug (part 10).

Replace filter element H.-SL, P... and VS.... The filter element with G... media is cleanable.

The efficiency of the cleaning process depends on the characteristics of contamination and the final pressure drop prior to servicing / cleaning the element. If the differential pressure after the filter element's cleaning process exceeds more than 50% of the pre service value the G... element also needs to be replaced.

Lubricate filter element O-ring and install replaced or cleaned filter element inside filter housing by putting it up to its locator and slightly turning .

Take care not to damage pleated filter element matrix during installation in filter housing. Remove the filter element's polyethylene protection sleeve when operation temperature is above 60°C or synthetic oil is used.

Check O-ring (part 7) in filter housing , replace in case of damage or wear. Screw on filter head without using a tool until the end of the thread. Turn it back 1/4 thread turn. (40 FLE...). Assemble filter cover with hexagon screw (100 FLE ...).

Operate filter as describe above.

Filter element service when using coreless EPE ECOPore® filter elements. Remove EPE ECOPore® filter element by slightly turning from the supporting tube . The supporting tube is re-usable and remains inside the filter housing.

Put on new EPE ECOPore® filter element over the supporting tube.

Warning

Assemble and disassemble filter only when system is switched off!

Vessel is under pressure!

Leave pressure equalisation valve closed while filter housing is out of service!

Do not change maintenance indicator or pressure equalisation valve when filter is under pressure!

Functions and safety warranty only with EPE-spare part!

Service filter only by trained personal!

Technical modifications reserved!

K. & H. Eppensteiner GmbH & Co. KG
Hardtwaldstraße 43 · D-68775 Ketsch/Rhein
Postfach 1120 · D-68768 Ketsch/Rhein
Telefon: 0 62 02/6 03-0
Telefax: 0 62 02/6 03-1 99
E-Mail: info@eppensteiner.de
Internet: www.eppensteiner.de

40B-GB/01/06.01/2000/Wei