



Donaldson Delivers

Stepped SealClamp™ Exhaust Clamp

Fewer Parts, Lighter Weight, Easy to Install

Easy to install preformed clamp for sealing muffler inlets, outlets, elbow joints, flex pipes and other system connections. Also minimizes noise and exhaust gas leaks.

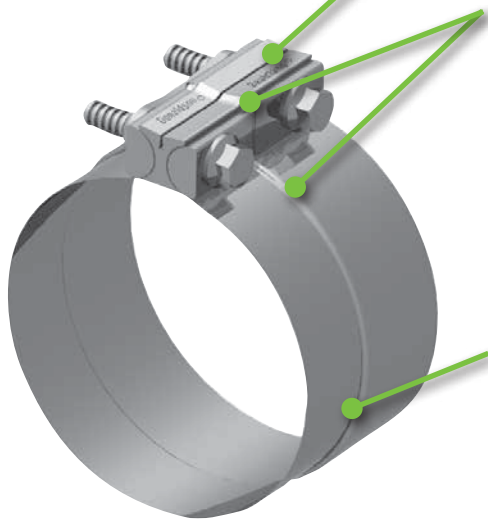

Bolts fit both 9/16" and 14mm wrenches

Features

Easier to install!

- Pre-assembled with fewer parts
- Requires less torque than other designs
- One wrench installation
- Reversible threaded nut bar

Visual torque indicator

- Lower torque makes for easier and quicker installation
- Groove provides a visual guide to proper torque

360° stepped shape improves joint seal

- Reduces exhaust leaks by more than 65% compared to other non-gasketed clamp designs
- Resistance to joint separation is nearly twice that of other brands
- Conforms tightly to overlapping connections – ideal for most over-lapping I.D. to O.D. joints
- Reduced flex pipe pinching
- Reduces exhaust noise

Quality materials

- 0.14-0.20 lbs. lighter than other brands
- Improved rust resistance
- Available in stainless or aluminized steel with aluminum and zinc-plated components
- High strength, grade 8 fasteners



Three Simple Installation Steps

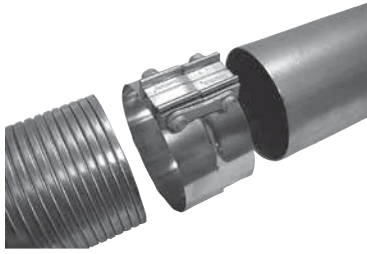

Position the SealClamp over the smallest tube. Larger end of the clamp must be on the overlapping tube or flex.

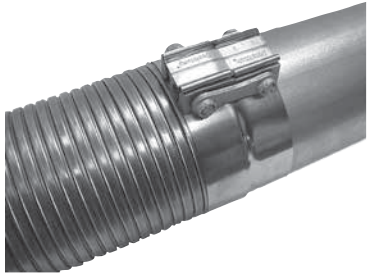

Locate the step of the clamp to the overlapping tube at the joint.

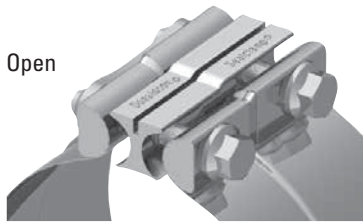

Open

Using the groove as a visual guide, alternately tighten bolts until the groove is approximately half closed (~50 ft. lbs).

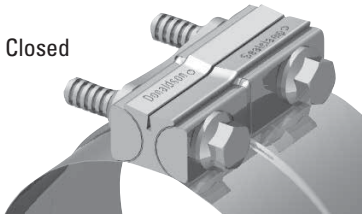

Closed

Note: Do not exceed 70 ft. lbs. torque as clamp damage may occur.



The unique stepped seal provides 360° sealing not available in competitive clamps

Order Information

O.D. PIPE		Part Number	
inches	mm	Aluminized	Stainless
2.50	64	n/a	X007829
3.00	76	X007833	X007830
3.50	89	X007834	X007831
4.00	102	X007824	X007784
5.00	127	X007805	X007785
6.00	152	n/a	X009076



Donaldson Company, Inc.
Minneapolis, MN

North America 800-374-1374
Mexico +52-449-910-6150
Latin Am. & Caribbean +52-449-910-6150
Brazil +55-11-2119-1604
Europe +32-16-38-3811
South Africa +27-11-997-6000

South East Asia 65-6311-7373
Greater China 852-2405-8388
Japan 81-42-540-4112
Australia 61-02-4350-2033
Korea 82-2-517-3333
India +91-124-2290060

donaldsonfilters.com
www.donaldson.com

Brochure No. F111098 ENG (9/12)

© 2012 Donaldson Company, Inc. All rights reserved. Donaldson Company, Inc. reserves the right to change or discontinue any model or specification at any time and without notice. Printed in the U.S.A.