



SERVICE BULLETIN

NUMBER: DCI-EC130-IBF-SB01
Date: 12 July 2021

REVISION: IR

SUBJECT: BACKSHELL FASTENER REPLACEMENT

A. EFFECTIVITY

Inlet Barrier Filter (IBF) systems, produced by the Donaldson Company, Inc. (DCI), formerly Aerospace Filtration Systems, Inc. (AFS), for following helicopter models:

Airbus Helicopters - Models: EC130B4 (STC SR02560CH)
EC130T2 (STC SR02560CH)
AS350B3 w/Dual Hydraulics (STC SR02560CH)

B. BACKGROUND

Donaldson was notified by one of its customers operating a DCI EC130 IBF system that during the regular scheduled maintenance interval of the IBF system, a fastener was found to become loose. The source of the loose fastener was discovered to be from a Backshell on the IBF system's wire harness. The Backshell is a military specification component.

C. ACTIONS

This is not a safety of flight issue, if operators follow Section 8.5.5.2 of the Instructions for Continued Airworthiness (ICA) and verify that Backshells are secure during regular maintenance intervals, then it is highly unlikely that the Backshell fasteners will come loose during flight. Nonetheless, Donaldson recommends a product improvement for all operators of the DCI EC130 IBF by replacing the existing fasteners on the Backshells of the 106113-205 Actuator and the 121400-101 Wire Harness with MS35275-230 screws and to safety wire the screws per NASM33540. Location of these screws can be found depicted in Figures 1 and 2. Inspection requirements for the Backshells will remain the same unless otherwise directed by a newer revision of the ICA (Reference 1).

Operators are recommended to locally procure the replacement hardware as applicable. If local procurement is not available, operators can procure the screws from Donaldson's ecommerce site found in the Contact section.

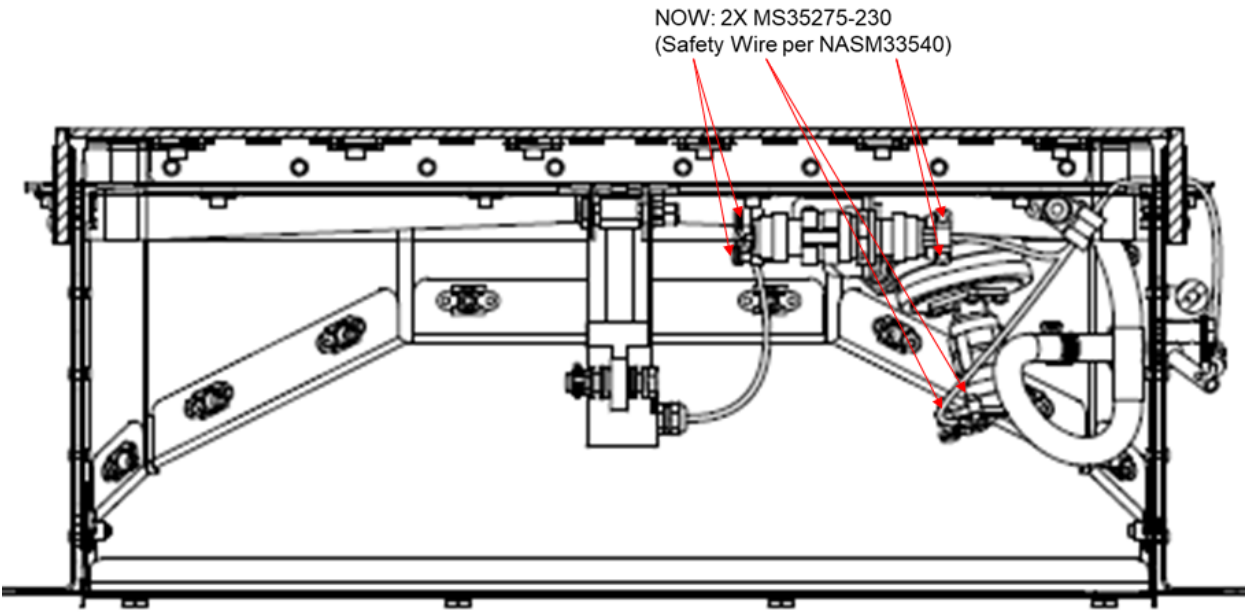

Figure 1 – Location of Backshell Screws Recommended for Replacement (I)

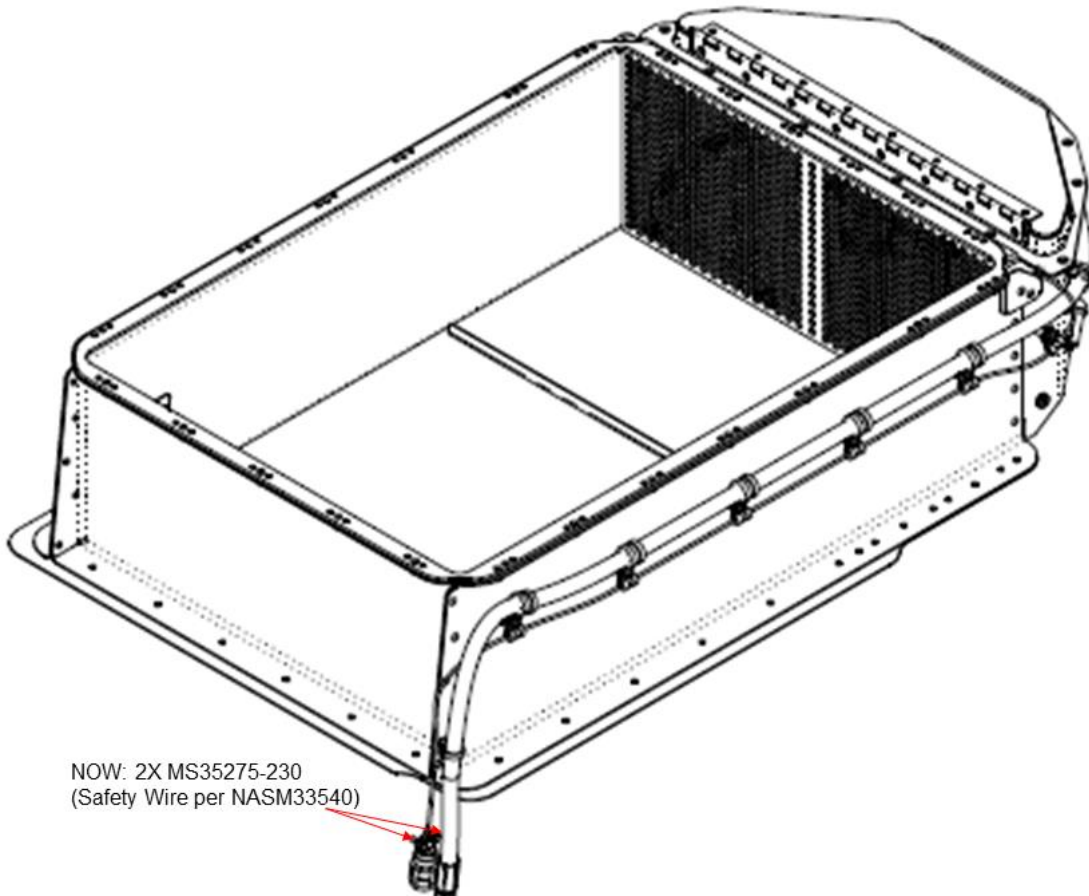

Figure 2 – Location of Backshell Screws Recommended for Replacement (II)

D. FAA APPROVAL

The design engineering aspects of this Bulletin have been shown to comply with the applicable Federal Aviation Regulations, and are FAA Approved.

E. REFERENCE DOCUMENTS

1. Donaldson Company, Inc. Instructions for Continued Airworthiness (ICA) – Document Number: AFS-EC130-IBF-ICA, Revision F.
2. FAA Advisory Circular, AC 29-2C, Certification of Transport Category Rotorcraft
3. FAA Advisory Circular, AC 27-1B, Certification of Normal Category Rotorcraft
4. FAA Advisory Circular, AC 43.13-1B, Acceptable Methods, Techniques, and Practices – Aircraft Inspection, Repair and Alterations

CONTACT INFORMATION

<https://shop.donaldson.com/store/en-us/product/MS35275-230/prod2140033>