



SERVICE BULLETIN

NUMBER: DCI-BH206B-IBF-SB02
Date: 13 July 2021

REVISION: IR

SUBJECT: BACKSHELL FASTENER REPLACEMENT

A. EFFECTIVITY

Inlet Barrier Filter (IBF) systems, produced by the Donaldson Company, Inc. (DCI), formerly Aerospace Filtration Systems, Inc. (AFS), for following helicopter model:

Bell Helicopter - Model: 206B (STC SR09451RC) (SN 0001 & SUBSQ)

B. BACKGROUND

Donaldson was notified by one of its customers operating a DCI IBF system, for an aircraft other than the Bell 206B, that during the regular scheduled maintenance interval of the IBF system, a fastener was found to become loose. The source of the loose fastener was discovered to be from a Backshell on the IBF system's wire harness. The Backshell is a military specification component. Out of an abundance of caution, Donaldson reviewed its IBF systems to determine which systems have similar designs to the system in which this incident occurred. The Donaldson Bell 206B IBF system has been found to use the same type Backshell.

C. ACTIONS

This is not a safety of flight issue, if operators follow Section 8.2.3 of the Instructions for Continued Airworthiness (ICA) and verify that Backshells are secure during regular maintenance intervals, then it is highly unlikely that the Backshell fasteners will come loose during flight. Nonetheless, Donaldson recommends a product improvement for all operators of the DCI Bell 206B IBF by replacing the existing fasteners on the Backshell of the 109401-101 Wire Harness connecting to the linear actuator & the Backshell of the linear actuator (106113-205) with MS35275-230 screws and to safety wire the screws per NASM33540. Location of these screws can be found depicted in Figure 1. Inspection requirements for the Backshells will remain the same unless otherwise directed by a newer revision of the ICA (Reference 1).

Operators are recommended to locally procure the replacement hardware as applicable. If local procurement is not available, operators can procure the screws from Donaldson's ecommerce site found in the Contact section.

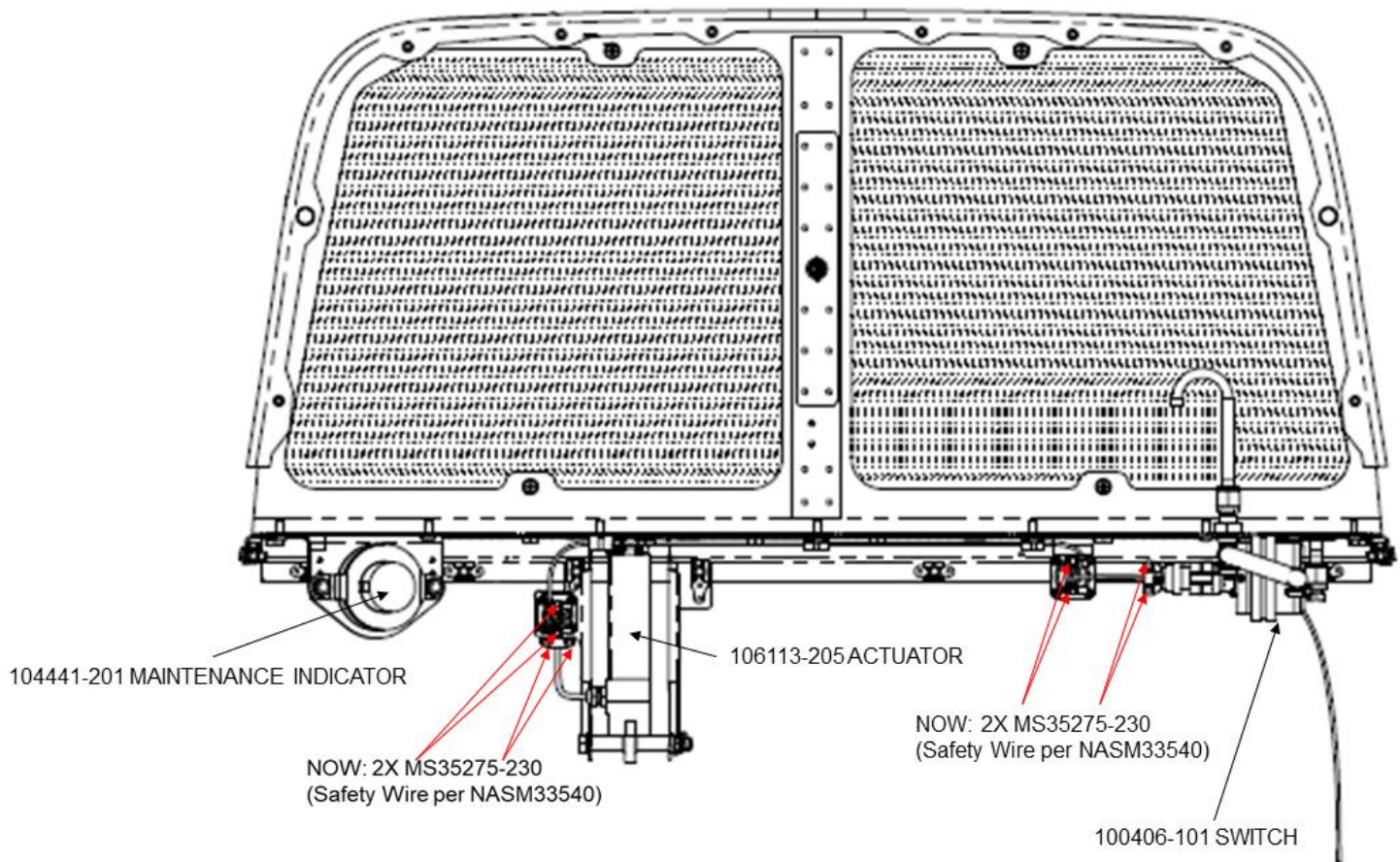

Figure 1 – Location of Backshell Screws Recommended for Replacement

D. FAA APPROVAL

The design engineering aspects of this Bulletin have been shown to comply with the applicable Federal Aviation Regulations, and are FAA Approved.

E. REFERENCE DOCUMENTS

1. Donaldson Company, Inc. Instructions for Continued Airworthiness (ICA) – Document Number: AFS-BH206B-IBF-KIT-ICA, Revision A.
2. FAA Advisory Circular, AC 29-2C, Certification of Transport Category Rotorcraft
3. FAA Advisory Circular, AC 27-1B, Certification of Normal Category Rotorcraft
4. FAA Advisory Circular, AC 43.13-1B, Acceptable Methods, Techniques, and Practices – Aircraft Inspection, Repair and Alterations

CONTACT INFORMATION

<https://shop.donaldson.com/store/en-us/product/MS35275-230/prod2140033>