



Donaldson
FILTRATION SOLUTIONS

Dryer Systems

Heatless Regenerating Adsorption Dryers

Ultracac[®] HED-ALD-MSD 0050 - 1000

MAIN FEATURES & BENEFITS

- Purification package incl. high-efficiency filters UltraPleat[®] S as pre- and afterfilter
- Pre filter with electronic level-controlled condensate drain incl. function control and alarm message
- Generous dimensioned filters:
large filtration surface, therefore low pressure drop and low operating costs
- Comprehensive option package:
dewpoint dependent capacity control, start-up-device, bypass line, pneumatic controller, free of silicone and parting agents, etc.
- 12 sizes available, matching to the compressor flow capacities, with 3 pressure dewpoint options
- Robust design with welded steel vessels and galvanized pipelines and press fittings with aerodynamic and leakage-proof design
- Service-friendly design of shuttle valves and solenoid valves for fast replacement of wear parts



HED-ALD-MSD
0050 - 1000

INDUSTRIES



- Chemical and electrical industry



- Machine building industry and plant engineering / construction



- Automotive industry

Donaldson Filtration Deutschland GmbH
Büssingstr. 1
D-42781 Haan
Tel.: +49 (0) 2129 569 0
Fax: +49 (0) 2129 569 100
E-Mail: CAP-de@donaldson.com
Web: www.donaldson.com

Donaldson[®]
Ultrafilter

PRODUCT DESCRIPTION

Compressed air is lead through the inlet of the dryer (J) and across the prefilter (3). At this stage, the air is cleaned from particles and condensate. The condensate is removed via the level-controlled electronic condensate drain (11).

Via the lower shuttle valve (9), the air is lead into the adsorption vessel (1), in which the air is dried down to the required dewpoint. Via the upper shuttle valve (9), the air is let into an afterfilter (4), in which possibly released particles from the desiccant bed are retained. Via the outlet (O), the clean and dry air is lead into the compressed air network and to the point of use.

While one vessel is in the drying phase (adsorption), the other vessel is being dried again (regeneration).

A partial stream of dried air is expanded to atmospheric pressure via a nozzle (6) and lead across the desiccant bed for regeneration and via a solenoid valve (5) and a silencer (7) to the atmosphere.

Typical applications for the adsorption dryers HED-ALD-MSD are:

- Central compressed air purification**
 Generation of dry, oil-free and particulate-free compressed air
- Point-of-use applications**
 Drying and purification of control and instrument and process air
- Automotive industry**
 Purification of compressed air for painting applications

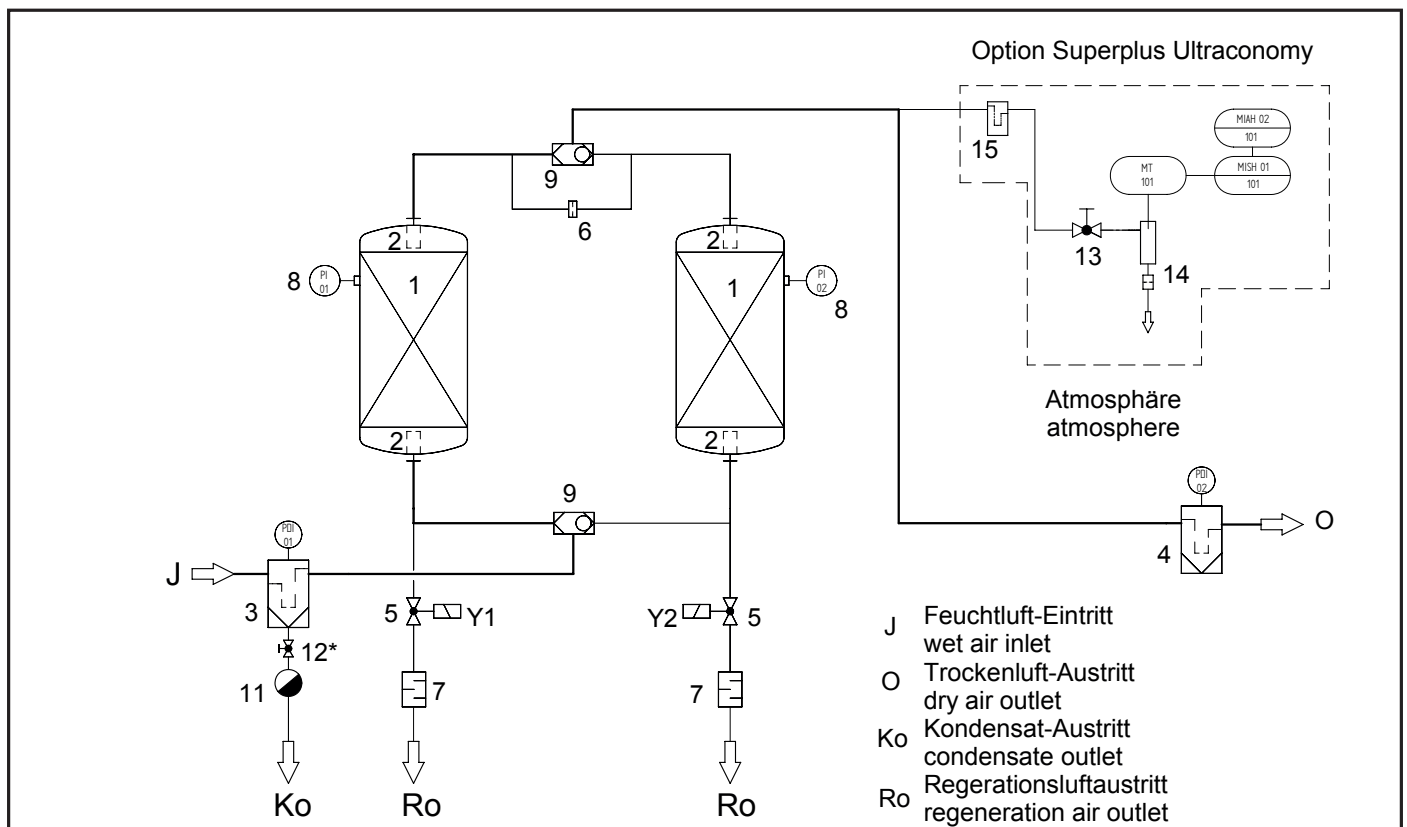

PRODUCT SPECIFICATIONS

Features:	Benefits:
Purification package incl. high-efficiency filters UltraPleat® S as pre and after filter	High oil- and water aerosol retention efficiency on pre- filter and high particulate retention efficiency on after filter at very low differential pressure
Pre filter with electronic level-controlled condensate drain incl. function control and alarm message	No compressed air loss through condensate drain, therefore reducing of operating costs; control of drain function ensures safe operation of dryer
All dryers in cabinet construction	Optimum protection against mechanical damage and against dirt
Welded steel vessels and galvanized pipelines and press fittings	Robust design with aerodynamic and leakage-proof design
Generous dimensioned filters	Large filtration surface, therefore low pressure drop and low operating costs
Intermittent operation standard	Link between dryer and compressor possible on central applications, therefore saving of compressed air
12 sizes available, matched to the compressor flows, with 3 selectable pressure dewpoints each	Custom made solutions possible, matching exactly customer's requirements; no oversizing of compressors necessary, due to lowest possible regeneration air requirements
Comprehensive option package: Dewpoint depending control, start-up device, bypass, pneumatics control, free of silicone and release agent etc.	Flexibility in application, well thought option package for economical operation and safe system installation in the compressed air network
Service-friendly design of shuttle valves	Fast replacement of wear parts ensure low service and maintenance cost and reduced downtime
Superplus Version including dewpoint dependent capacity control and text display	Saving of energy and operational cost due to adaption of the purge air consumption to the actual operating conditions. Indication of current dewpoint and function status as well as alarm and service messages on LCD text display in clear text ensures high operating safety of the adsorption dryer.

Technical Data	
Operating pressure:	min. 4 bar (g) / max. 16 bar (g)
Ambient temperature:	min. +4°C / max. +50°C
Medium temperature:	max. +50°C
Medium:	Compressed air / nitrogen
Power supply:	230 VAC / 50-60 Hz or 115 VAC / 50-60 Hz or 24 VDC
Power consumption	40 W
Declaration of Conformity	
Types 0050 - 0175:	acc. to Directive 2014/35/EU
Types 0225 - 1000:	acc. to PED 2014/68/EU
Pressure vessel – design, manufacture, testing	
Adsorber:	acc. to Directive 2014/29/EU
Filter:	acc. to PED 2014/68/EU

PRODUCT SPECIFICATIONS

HED/ ALD/ MSD	Volume flow in m³/h (1 bar, 20°C)*	Regeneration air losses average m³/h (1 bar, 20°C)			Volume flow out (min.) m³/h (1 bar, 20°C)			Pressure loss initial mbar	Prefilter and Afterfilter UltraPleat® S
		HED	ALD	MSD	HED	ALD	MSD		
0050	50	7,0	7,5	10	41,4	40,8	37,7	70	0210
0080	80	11,2	12,0	16	66,2	65,2	60,3	85	0210
0100	100	14,0	15,0	20	82,8	81,6	75,4	90	0210
0150	150	21,0	23,0	30	124,2	121,7	113,1	140	0210
0175	175	24,5	26,3	35	144,9	142,7	132,0	75	0210
0225	225	31,5	34,0	45	186,3	183,2	170,0	90	0450
0300	300	42,0	45,0	60	248,3	244,7	226,2	125	0450
0375	375	52,5	56,0	75	310,4	306,1	282,8	150	0450
0550	550	77,0	83,0	110	455,3	447,9	414,7	150	0600
0650	650	91,0	98,0	130	538,1	529,5	490,1	185	0750
0850	850	119,0	128,0	170	703,6	692,6	640,9	220	1100
1000	1000	140,0	150,0	200	827,8	815,5	754,0	185	1100

* related to 1 bar (abs) and 20 °C at intake of compressor and 7 bar (g) and 35 °C inlet temperature

Compressed air quality class according to ISO 8573-1		
HED	ALD	MSD
1-2 : 3 : 2	1-2 : 2 : 2	1-2 : 1-2 : 2

SIZING

Type	Pressure dewpoint (PDP)	Residual water content	Inlet temperature	Operating pressure (bar)												
				4	5	6	7	8	9	10	11	12	13	14	15	16
HED ALD	-20°C	0,88 g/m³ 0,11 g/m³	25°C	0,75	0,90	1,05	1,20	1,35	1,50	1,65	1,80	1,95	2,10	2,25	2,40	2,55
	30°C		0,69	0,83	0,96	1,10	1,24	1,38	1,51	1,65	1,79	1,93	2,06	2,20	2,34	
	35°C		0,63	0,75	0,88	1,00	1,13	1,25	1,38	1,50	1,63	1,75	1,88	2,00	2,13	
MSD	-40°C	0,11 g/m³ 0,11 g/m³ 0,0027 g/m³	25°C	0,75	0,90	1,05	1,20	1,35	1,50	1,65	1,80	1,95	2,10	2,25	2,40	2,55
	30°C		0,69	0,83	0,96	1,10	1,24	1,38	1,51	1,65	1,79	1,93	2,06	2,20	2,34	
	35°C		0,63	0,75	0,88	1,00	1,13	1,25	1,38	1,50	1,63	1,75	1,88	2,00	2,13	
	40°C		0,50	0,60	0,70	0,80	0,90	1,00	1,10	1,20	1,30	1,40	1,50	1,60	1,70	
	45°C		0,44	0,53	0,61	0,70	0,79	0,88	0,96	1,05	1,14	1,23	1,31	1,40	1,49	
	50°C		0,31	0,38	0,44	0,50	0,56	0,63	0,69	0,75	0,81	0,88	0,94	1,00	1,06	
* on request			Correction factors (f)													

Example:

$\dot{V}_{nom} = 200 \text{ m}^3/\text{h}$, inlet temperature = 30°C, operating pressure = 10 bar (g), PDP = -40°C

$$\dot{V}_{korr} = \frac{\dot{V}_{nom}}{f} = \frac{200 \text{ m}^3/\text{h}}{1,51} = 132,5 \text{ m}^3/\text{h}$$

Calculated dryer size:
ALD, Type 0150

DIMENSIONS

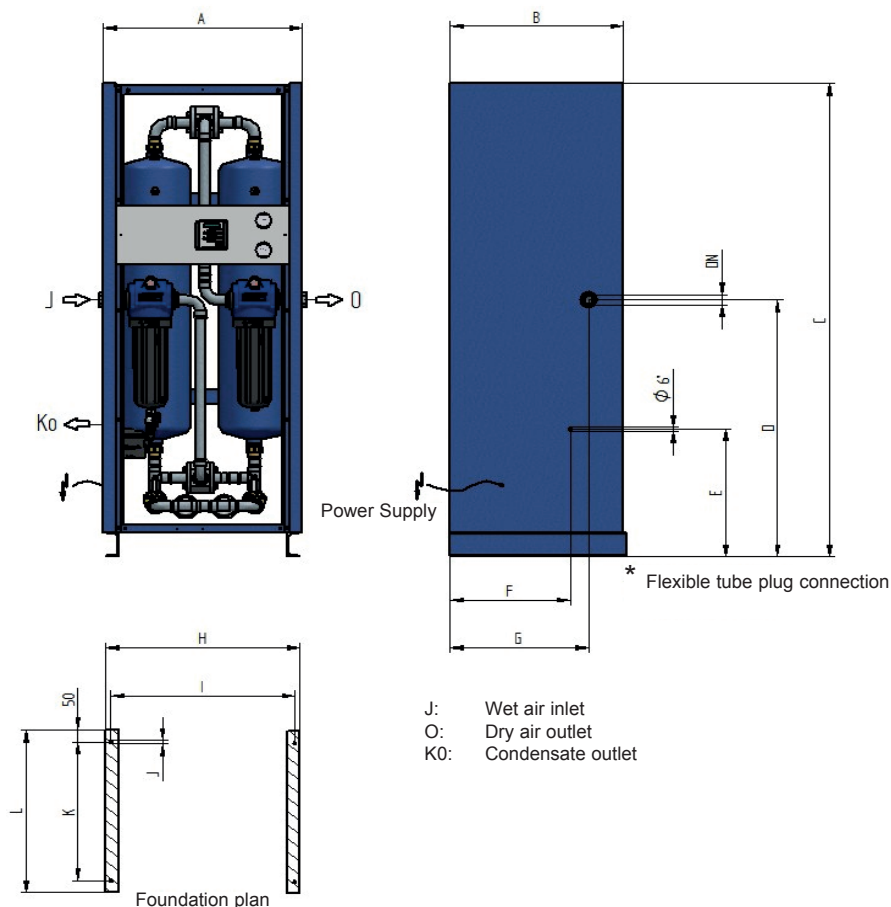

Type	DN "	A mm	B mm	C mm	D mm	E mm	F mm	G mm	H mm	I mm	J mm	K mm	L mm	Weight kg
0050	G 3/4	670	460	1610	800	415	315	340	650	610	13	360	460	107
0080	G 3/4	670	460	1610	800	415	315	340	650	610	13	360	460	140
0100	G 1	670	460	1610	800	415	315	340	650	610	13	360	460	169
0150	G 1	770	680	1980	1075	535	465	535	750	710	13	580	680	200
0175	G 1	770	680	1980	1075	535	465	535	750	710	13	580	680	260
0225	G 1 1/2	770	680	1980	1075	535	465	535	750	710	13	580	680	277
0300	G 1 1/2	770	680	1980	1075	535	465	535	750	710	13	580	680	321
0375	G 1 1/2	950	770	2190	1250	660	530	620	930	890	13	670	770	398
0550	G 2	950	770	2190	1250	660	530	620	930	890	13	670	770	431
0650	G 2	950	770	2190	1250	660	530	620	930	890	13	670	770	506
0850	G 2	1100	880	2350	1450	650	650	720	1080	1040	13	780	880	595
1000	G 2	1100	880	2350	1450	650	650	720	1080	1040	13	780	880	676