



Donaldson
FILTRATION SOLUTIONS

Compressed Air Filtration Cyclone Separator

DF-C

MAIN FEATURES & BENEFITS:

- Innovative cyclone insert for high retention rate and low pressure loss
- Intelligent overall concept meet requirements of industrial air purification
- Flow-optimised design, minimum pressure loss for economic compressed air purification (saving of energy costs)
- Compact, service friendly construction due to bayonet fixing, low space requirement and simply handling during exchange of filter element
- Dip coating for longtime corrosion protection as well as with aggressive condensates

INDUSTRIES



- Chemical and pharmaceutical industry



- PCB assembly and CD manufacturing



- Surface finishing



- Machine building industry and plant engineering / construction



- Energy and power generation



Version Superplus

Donaldson Filtration Deutschland GmbH
Büssingstr. 1
D-42781 Haan
Tel.: +49 (0) 2129 569 0
Fax: +49 (0) 2129 569 100
E-Mail: CAP-de@donaldson.com
Web: www.donaldson.com

Donaldson®
Ultrafilter

PRODUCT DESCRIPTION

The cyclone separators DF-C are designed for the processing of compressed air or other gases in industrial applications.

The units offer a high degree of separation over a large flow range with small pressure losses. This is ensured by an innovative spin insert and a flow-optimised design of the housing.

This product series DF-C offers 7 different housings with a flow range between 50 and 1100 m³/h (related to 7 bar (g)).

The cyclone separator is conform to the requirements of the European directive 2014/68/EU for pressure vessels.

Function description:

Through the innovative insert in the cyclone head the inlet air flow is moved into a fast rotating drive, which centrifuges larger particles due to their mass inertia against the inner housing wall. Through friction with the housing the particles lose part of their kinetic energy and slide down with reduced speed towards housing ground. The collected condensate on the housing ground is removed via condensate drain, while the purified compressed air is made available to the system

Two versions are available:

Standard

Type with time controlled condensate drain UFZ

Superplus

Type with level-controlled condensate drain UFM-D



The DF-C cyclone separators are designed and developed for the following applications:

- **Central compressed air processing:**
 - Removal of liquids and aerosols downstream aftercoolers
 - Pre-purification stage upstream high efficiency filters

PRODUCT SPECIFICATIONS

Features	Benefits
Flow-optimised design of the housing	Low pressure losses, thereby saving energy costs
Innovative spin insert	High retention rates over a large volume flow range
Intelligent overall concept	Series range, retention rates and available options perfectly meet requirements of industrial air purification. Adequate to the industrial filter series DF
Bayonet fixing between housing head and housing bowl	Easy to use construction, simple inspection and cleaning of the housing
Housing cannot be opened under pressure due to bayonet lock	High safety during operation
Housings immersion-laquererd on the inside and outside surface	Long-term corrosion protection, also against aggressive condensates

Options	
UFM-D	Electronic level-controlled condensate drain without compressed air losses
UFZ	Time-controlled condensate drain
Wall bracket	Distance to the wall gradelessly adjustable
Connection adapter	Intelligent adapter solution for filter combination

Cyclone Separator DF-C Differential Pressures			
No.	Type	Nominal flow m ³ /h ¹⁾	Δp ²⁾ mbar
1	0050	50	95
2	0120	120	60
3	0210	210	50
4	0320	320	65
5	0450	450	40
6	0750	750	55
7	1100	1100	70

¹⁾ Volume flow related to 1 bar (absolute) / 20°C

²⁾ Differential pressure related to 8 bar (absolute) operating pressure

Full retention rate related to 8 bar a:	
$\geq 5 \mu\text{m}$	99%
$\geq 10 \mu\text{m}$	100%

MATERIALS/ DIMENSIONS

STANDARD

Pos.	Piece	Description
1	1	Housing head
2	1	Housing bowl
3	2	Wall bracket (option)
4	1	Drain UFZ

Materials:	
Filter housing	Aluminium die cast
Float drain	Brass
Sealing/ O-ring	Viton/NBR

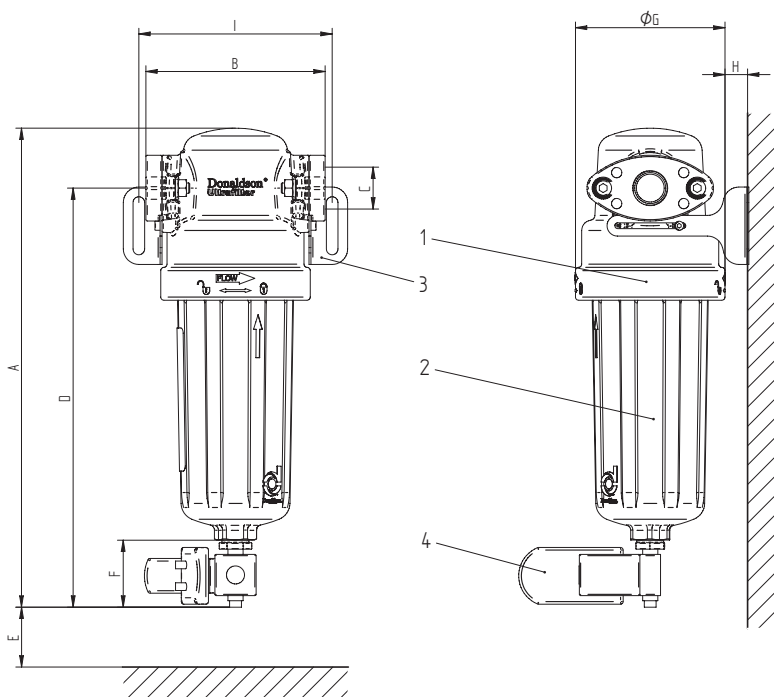

Classification acc. to 2014 / 68 / EU for fluids group 2	
DF-C 0050 - DF-C 0320	Art. 4, par. 3
DF-C 0450 - DF-C 1100	Cat. I

Max. operating pressure	16 bar
Test pressure	22,9 bar
Perm. operating temperature	+1°C / +65°C

Size	Flow rate* m³/h	Volume (l)	Weight (kg)	A mm	B mm	C	D mm	E mm	F mm	Ø G mm	H min./ max. mm	I mm
0050	50	0,28	0,78	243,5	76	G 3/8	211,0	50	52	66	16,0	84
0120	120	0,56	1,12	286,0	103	G 1/2	246,5	50	52	85	14,5 / 45,0	107
0210	210	1,47	2,18	371,5	139	G 3/4	325,0	60	52	116	15,5 / 66,0	150
0320	320	1,47	2,18	371,5	139	G 1	325,0	60	52	116	15,5 / 66,0	150
0450	450	5,42	5,32	575,5	190	G 1 1/2	512,5	70	52	160	25,0 / 95,0	190
0750	750	5,42	5,32	575,5	190	G 2	512,5	70	52	160	25,0 / 95,0	190
1100	1100	5,42	5,32	575,5	190	G 2	512,5	70	52	160	25,0 / 95,0	190

* Nominal flow at 7 bar g, m³/h related to 1 bar abs. and 20°C

MATERIALS/ DIMENSIONS

SUPERPLUS

Pos.	Pcs.	Description
1	1	Housing head
2	1	Housing bowl
3	2	Wall bracket (option)
4 DF-C 0050- DF-C 0320	1	Drain UFM-D05
5 DF-C 0450 - DF-C 1100	1	Drain UFM-D10

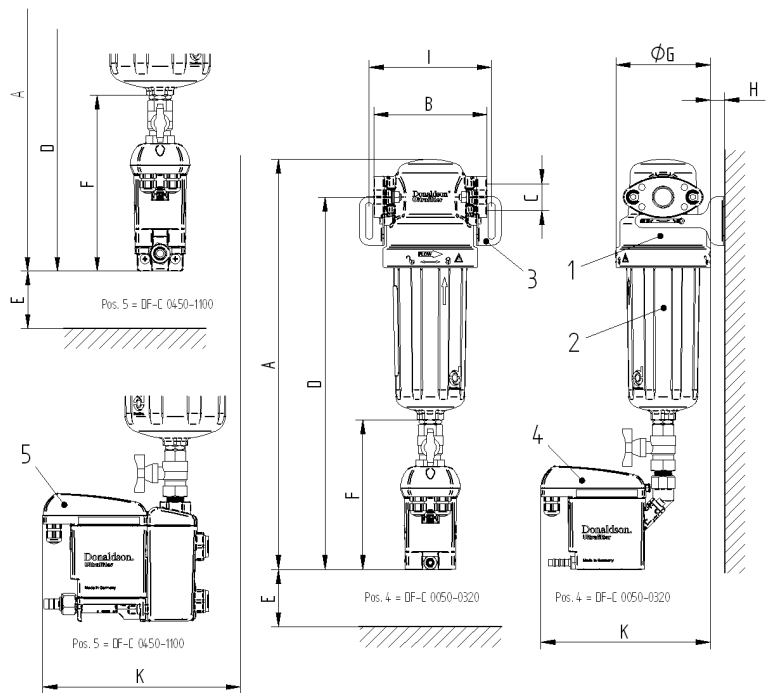

Materials:	
Filtergehäuse	Aluminium-Druckguß
UFM-D	Aluminium/ Reinforced polymer
Sealings/ O-ring	Viton/ NBR

Classification acc. to 2014 / 68 / EU for fluids group 2	
DF-C 0050 - DF-C 0320	Art. 4, par. 3
DF-C 0450 - DF-C 1100	Cat. I

Max. operating pressure	16 bar
Test pressure	22,9 bar
Perm. operating temperature	+1°C / +65°C

Size	Flow rate* m³/h	Volume (l)	Weight (kg)	A mm	B mm	C	D mm	E mm	F mm	Ø G mm	H min./ max. mm	I mm	K mm
0050	50	0,28	1,34	375,0	76	G 3/8	342,5	70	183,5	66	16,0	84	183,0
0120	120	0,56	1,68	417,5	103	G 1/2	378,0	70	183,5	85	14,5 / 45,0	107	193,0
0210	210	1,47	2,74	503,0	139	G 3/4	456,5	70	183,5	116	15,5 / 66,0	150	208,0
0320	320	1,47	2,74	503,0	139	G 1	456,5	70	183,5	116	15,5 / 66,0	150	208,0
0450	450	5,42	5,88	739,0	190	G 1 1/2	676,0	70	215,5	160	25,0 / 95,0	190	242,5
0750	750	5,42	5,88	739,0	190	G 2	676,0	70	215,5	160	25,0 / 95,0	190	242,5
1100	1100	5,42	5,88	739,0	190	G 2	676,0	70	215,5	160	25,0 / 95,0	190	242,5

* Nominal flow at 7 bar g, m³/h related to 1 bar abs. and 20°C