



Downflo® Oval

DFO 2-8, 2-12, 2-16, 2-24, 2-36
3-10, 3-12, 3-18, 3-24, 3-36, 3-48, 3-60, 3-72,
4-16, 4-32, 4-48, 4-64, 4-80, 4-96, 4-112, and 4-128

Installation and Operation Manual

Installation, Operation, and Service Information

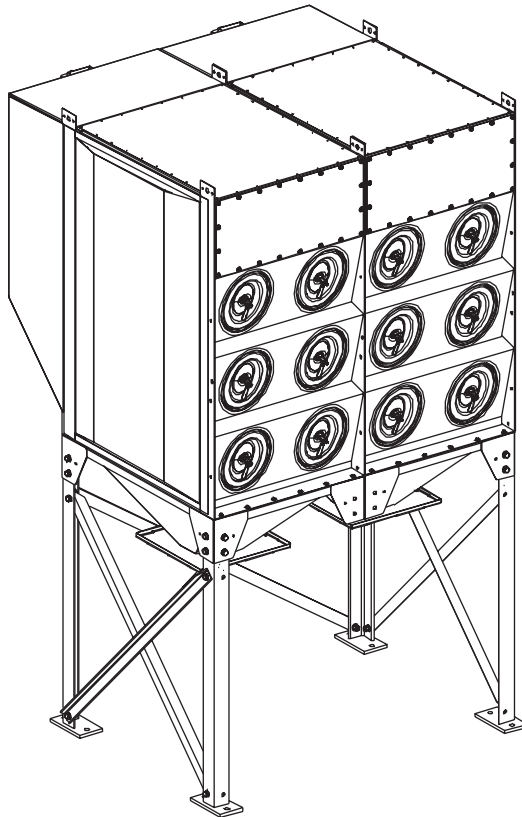

This manual is property of the owner. Leave with the unit when set-up and start-up are complete. Donaldson Company reserves the right to change design and specifications without prior notice.

Illustrations are for reference only as actual product may vary.



This is the safety alert symbol. It is used to alert you to potential personal injury hazards. Obey all safety messages that follow this symbol to avoid possible injury or death.

WARNING

Process owners/operators have important responsibilities relating to combustible hazards. Process owners/operators must determine whether their process creates combustible dust, fume, or mist. If combustible dust, fume, or mist is generated, process owners/operators should at a minimum:

- Comply with all applicable codes and standards. Among other considerations, current NFPA standards require owners/operators whose processes involve potentially combustible materials to have a current Hazard Analysis, which can serve as the foundation for their process hazard mitigation strategies.
- Prevent all ignition sources from entering any dust collection equipment.
- Design, select, and implement fire and explosion mitigation, suppression, and isolation strategies that are appropriate for the risks associated with their application.
- Develop and implement maintenance work practices to maintain a safe operating environment, ensuring that combustible dust, fume, or mist does not accumulate within the plant.

Donaldson recommends process owners/operators consult with experts to insure each of these responsibilities are met.

As a manufacturer and supplier of Industrial Filtration Products, Donaldson can assist process owners/operators in the selection of filtration technologies. However, process owners/operators retain all responsibility for the suitability of fire and explosion hazard mitigation, suppression, and isolation strategies. Donaldson assumes no responsibility or liability for the suitability of any fire and/or explosion mitigation strategy, or any items incorporated into a collector as part of an owner/operators hazard mitigation strategy.

Improper operation of a dust control system may contribute to conditions in the work area or facility that could result in severe personal injury and product or property damage. Check that all collection equipment is properly selected and sized for the intended use.

DO NOT operate this equipment until you have read and understand the instruction warnings in the Installation and Operations Manual. For a replacement manual, contact Donaldson Torit.

This manual contains specific precautionary statements relative to worker safety. Read thoroughly and comply as directed. Discuss the use and application of this equipment with a Donaldson Torit representative. Instruct all personnel on safe use and maintenance procedures.

Data Sheet

Model Number _____	Serial Number _____
Ship Date _____	Installation Date _____
Customer Name _____	
Address _____	

Filter Type _____	
Accessories _____	
Other _____	



Contents

Description.....	1	Optional Equipment.....	23
Purpose and Intended Use	1	Power Pack From DCI.....	23
Rating and Specification Information.....	2	Power Pack From Europe.....	24
Operation.....	3	Side-Mount Power Pack.....	25
Inspection on Arrival.....	4	55-Gallon Drum Pack.....	25
Installation Codes and Procedures	4	Magnehelic Gauge	27
Installation.....	4	Photohelic Gauge	29
Site Selection, Grade-Mounted Units.....	4	Delta P Control.....	31
Unit Location	4	Delta P C-01 Control.....	31
Rigging Instructions.....	5	Delta P Plus Control	32
Hoisting Information	5	Transition and Rotary Valve.....	33
Electrical Wiring.....	5	Damper and Silencer, TBI.....	34
Typical Installation.....	6	Plenum Silencer, TRB	35
Standard Equipment.....	7	Abrasion-Resistant Inlet Collar.....	35
Field Assembly.....	7	Extended Dirty-Air Plenum	36
Leg and Hopper Installation	7	Air Management Module.....	36
Module Assembly.....	9	Platforms and Ladders	37
Deflector Plate, Yoke, Venturi, and Filter Installation...11		Cold Climate Kit.....	38
Compressed Air Installation	13	Explosion Vents	39
Solid-State Timer Installation.....	15	Troubleshooting.....	40
Solenoid Connection.....	15	Service Notes	43
Timer and Solenoid Specifications.....	15		
Preliminary Start-Up Check	17		
Maintenance Information.....	19		
Operational Checklist	19		
Filter Removal and Installation.....	19		
Filter Removal	19		
Dust Disposal.....	21		
Compressed Air Components.....	21		

Magnehelic® and Photohelic® are registered trademarks of Dwyer Instruments, Inc.

DANGER

DANGER indicates a hazardous situation which, if not avoided, will result in death or serious injury.

WARNING

WARNING indicates a hazardous situation which, if not avoided, could result in death or serious injury.

CAUTION

CAUTION, used with the safety alert symbol, indicates a hazardous situation which, if not avoided, could result in minor or moderate injury.

NOTICE

NOTICE is used to address practices not related to personal injury that may result in damage to equipment.

Description

The Downflo Oval dust collector is a continuous-duty, modular collector with cartridge-style filters. The downward airflow design delivers high filtration efficiency while using less energy. Continuous-duty means no downtime. The filters are pulse-cleaned in sequence, one set at a time, without turning the unit off. The modular design allows flexibility in system design and adapts easily to limited space areas. Each standard module is two or three filter rows wide by two, three, or four rows high by two filters deep.

Designed to increase the versatility of the unit, standard options include abrasion-resistant inlets, extended dirty-air plenums, and air management modules.

Purpose and Intended Use

Downflo Oval collectors are widely used on nuisance dust where the load to the collector is less than five grains per cubic foot. Some typical applications include abrasive blasting, grinding, pharmaceuticals, powder paint applications, sand handling, and welding. Each application is different and selecting the correct filter cartridge for the application and type of dust collected is important.

- For all ambient, extremely fine, and non-fibrous dust, use Ultra Web® filter cartridges which offer high efficiency and performance on fine particulate.
- For fibrous dust, use a cartridge with an open-pleat design, such as Fibra-Web®.
- Operations involving high temperature and high humidity may require special attention. Temperature, moisture content, and chemistry issues may require custom collector design. Appropriate cartridge options are available from Donaldson Torit.
- Hygroscopic dust such as fertilizer, salt, and sugar should be handled under a controlled, low humidity environment. Contact Donaldson Torit for filter cartridge selection.
- Flammable or explosive dust may require custom collector design options and special cartridges. Contact Donaldson Torit for design assistance.
- Applications with high hydrocarbon or high oil content may require special treatment or filter media.

WARNING

Combustible materials such as buffing lint, paper, wood, metal dusts, weld fume, or flammable coolants or solvents represent potential fire and/or explosion hazards. Use special care when selecting, installing, and operating all dust, fume, or mist collection equipment when such combustible materials may be present in order to protect workers and property from serious injury or damage due to a fire and/or explosion.

Consult and comply with all National and Local Codes related to fire and/or explosion properties of combustible materials when determining the location and operation of all dust, fume, or mist collection equipment.

Standard Donaldson Torit equipment is not equipped with fire extinguishing or explosion protection systems.

Rating and Specification Information

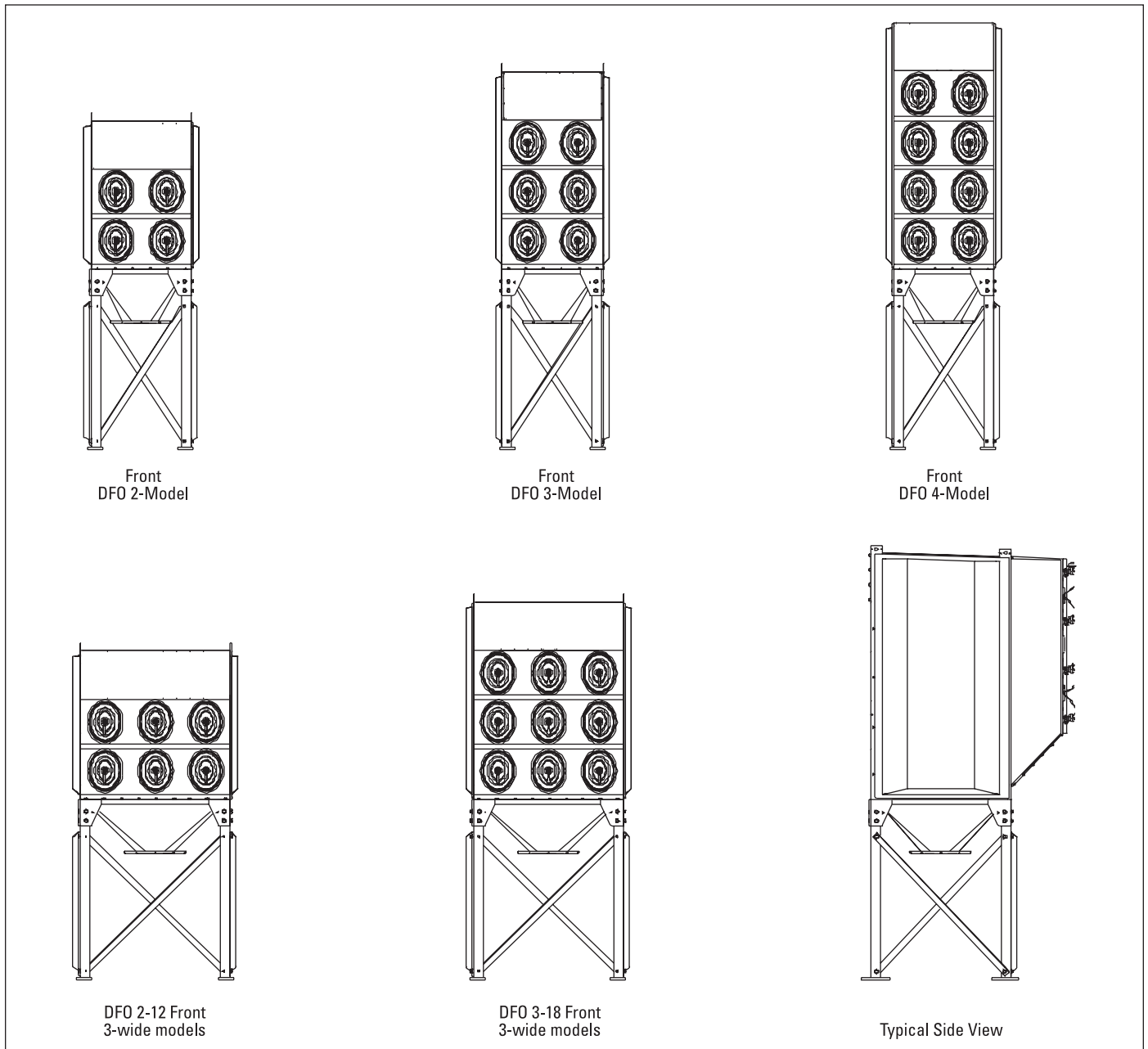

All Units (as per IBC 2006 Specifications*):

Seismic Spectral Acceleration, S 1.5 g
 Seismic Spectral Acceleration, S_1^s 0.6 g
 Installed Unit Base Elevation Grade
 Occupancy Category II
 Compressed air, maximum psig 90-100
 Housing rating, inches water gauge - 20
 Power and controls 220-Volt 50/60 Hz

*If unit was supplied with a Record Drawing, the specifications on the drawing will supersede the standard specifications above.

Operation

During normal operation, dust-laden air enters the unit through the dirty-air inlet. Airflow is directed downward through the collector and heavier particulate falls directly into the hopper. The cartridges remove fine particulate and clean, filtered air passes through the cartridge to the clean-air plenum and discharges through the clean-air outlet.

Filter cleaning is completed using pulse-jet technology. A solenoid and diaphragm valve aligned to each row of filters provides the pulse cleaning. The cleaning sequence starts at the top filter row and continues down through each module. Remove, inspect, or change the cartridges from outside the unit by removing the filter access cover and sliding the filters out.

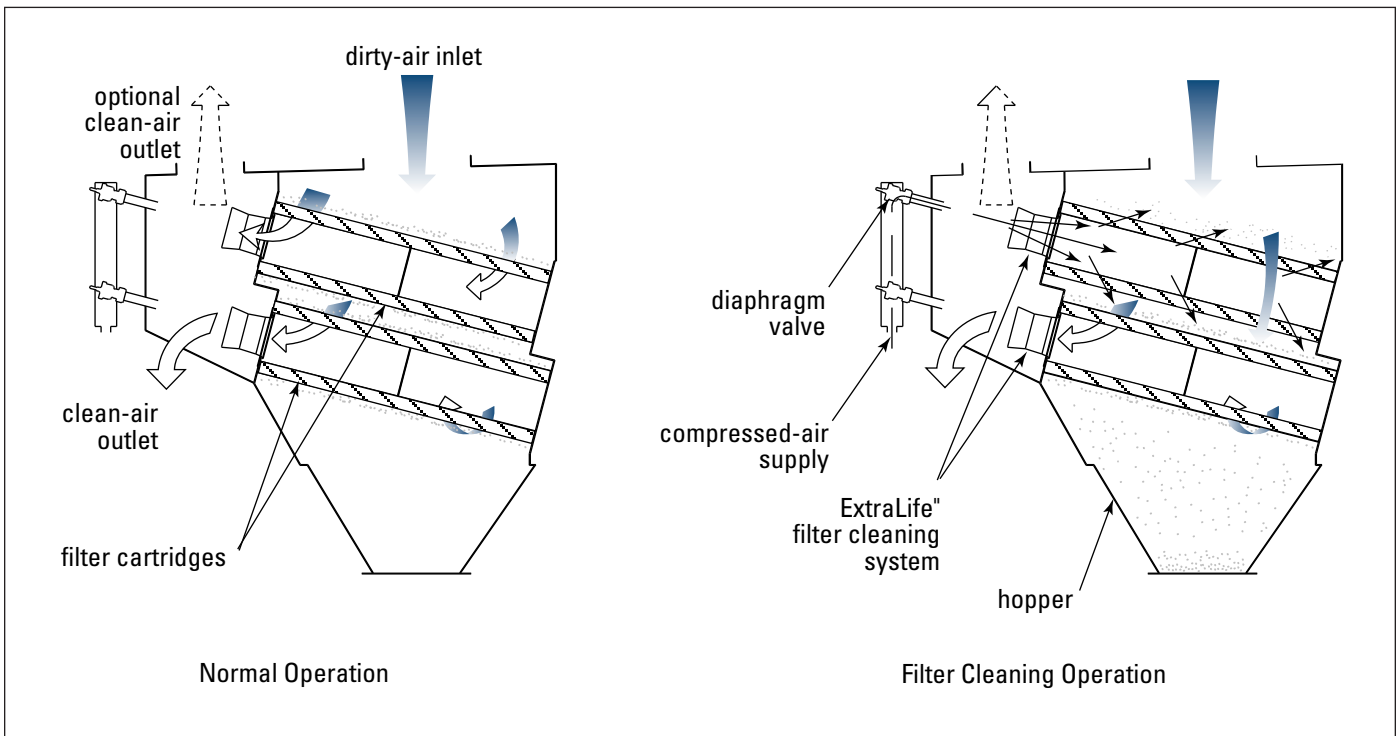

Unit Operation

Inspection on Arrival

1. Inspect unit on delivery.
2. Report any damage to the delivery carrier.
3. Request a written inspection report from the Claims Inspector to substantiate any damage claim.
4. File claims with the delivery carrier.
5. Compare unit received with description of product ordered.
6. Report incomplete shipments to the delivery carrier and your Donaldson Torit representative.
7. Remove crates and shipping straps. Remove loose components and accessory packages before lifting unit from truck.
8. Check for hardware that may have loosened during shipping.
9. Use caution removing temporary covers.

Installation Codes and Procedures



WARNING

Codes may regulate recirculating filtered air in your facility.

Consult with the appropriate authorities having jurisdiction to ensure compliance with all national and local codes regarding recirculating filtered air.

Safe and efficient operation of the unit depends on proper installation.

Authorities with jurisdiction should be consulted before installing to verify local codes and installation procedures. In the absence of such codes, install unit according to the National Electric Code, NFPA No. 70-latest edition and NFPA 91 (NFPA 654 if combustible dust is present).

A qualified installation and service agent must complete installation and service of this equipment.

All shipping materials, including shipping covers, must be removed from the unit prior to, or during unit installation.

NOTICE

Failure to remove shipping materials from the unit will

compromise unit performance.

Inspect unit to ensure all hardware is properly installed and tight prior to operating collector.

Installation



CAUTION

Site suitability must account for wind, seismic zone, and other live-load conditions when selecting the location for all units.

Codes may regulate acceptable locations for installing dust collectors. Consult with the appropriate authorities having jurisdiction to ensure compliance with all national and local codes regarding dust collector installation.

Site Selection, Grade-Mounted Units

1. The unit can be located on a reinforced concrete foundation or rooftop.
2. Provide clearance from heat sources and interference with utilities when selecting the location for suspended units.
3. Portable units require no special installation accommodations.

Note: Units with explosion vents are not available in portable configurations.

When outdoor locations are selected, always mount motors with drain holes pointed down for proper drainage of moisture.

Unit Location



WARNING

Donaldson Torit equipment is not designed to support site-installed ducts, interconnecting piping, or electrical services. All ducts, piping, or electrical services supplied by others must be adequately supported to prevent severe personal injury and/or property damage.

When hazardous conditions or materials are present, consult with local authorities for the proper location of the collector

Foundation must be capable of supporting the entire weight of the unit, plus the weight of the collected material, piping, and ductwork.

Prepare the foundation in the selected location. Install anchor bolts to extend a minimum of 1 3/4-inches above foundation.

Locate the collector to ensure easy access to electrical and compressed-air connections and routine maintenance.

If explosion protection devices are part of the system, locate the collector in accordance with local code requirements (Example: NFPA 654). These codes may require units handling combustible dust be located either outside or against an exterior wall.

Rigging Instructions

Suggested Tools & Equipment

Clevis Pins and Clamps	Lifting Slings
Crane or Forklift	Pipe Sealant
Drift Pins	Pipe Wrenches
Drill and Drill Bits	Screwdrivers
End Wrenches	Socket Wrenches
Adjustable Wrench	Spreader Bars
Torque Wrench (inch/lbs, 9/16-in Socket)	

Hoisting Information



Failure to lift the collector correctly can result in severe personal injury or property damage.

Use appropriate lifting equipment and adopt all safety precautions needed for moving and handling the equipment.

A crane or forklift is recommended for unloading, assembly, and installation of the collector.

Location must be clear of all obstructions, such as utility lines or roof overhang.

Use all lifting points provided.

Use clevis connectors, not hooks, on lifting slings.

Use spreader bars to prevent damage to unit's casing.

Check the Specification Control drawing for weight and dimensions of the unit and components to ensure adequate crane capacity.

Allow only qualified crane operators to lift the equipment.

Refer to applicable OSHA regulations and local codes when using cranes, forklifts, and other lifting equipment.

Lift unit and accessories separately and assemble after unit is in place.

Use drift pins to align holes in section flanges during assembly.

Electrical Wiring



Electrical work must be performed by a qualified electrician and comply with all applicable national and local codes.

Turn power off and lock out electrical power sources before performing service or maintenance work.

Do not install in classified hazardous atmospheres without an enclosure rated for the application.

All electrical wiring and connections, including electrical grounding, should be made in accordance with the National Electric Code (NFPA No. 70-latest edition).

Check local ordinances for additional requirements that apply.

The appropriate wiring schematic and electrical rating must be used. See unit's rating plate for required voltage.

If the unit is not furnished with a factory-mounted disconnect, an electric disconnect switch having adequate amp capacity shall be installed in accordance with Part IX, Article 430 of the National Electrical Code (NFPA No. 70-latest edition). Check unit's rating plate for voltage and amperage ratings.

Refer to the wiring diagram for the number of wires required for main power wiring and remote wiring.

Typical Installation

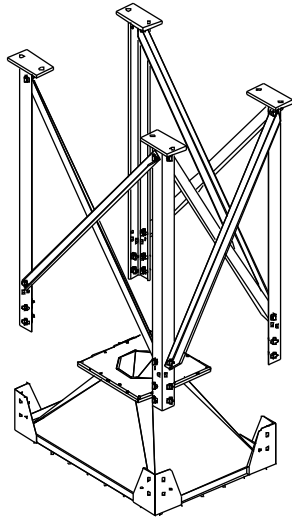

1. Place hopper discharge-side up on ground or other level surface and attach legs to hopper.
2. Assemble leg cross braces.
3. Turn hopper and leg assembly over and lift into position over anchor bolts.
4. Level hopper.
5. Tighten all fasteners securely.
6. Apply rope sealant to hopper flange.
7. Lift unit over leg and hopper assembly and lower slowly.
8. Secure with bolts, washers, and nuts supplied.
9. Remove crane.
10. Apply sealant to hopper/cabinet seam.

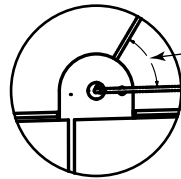
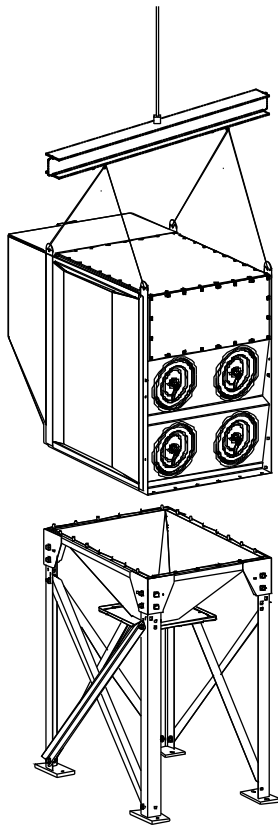
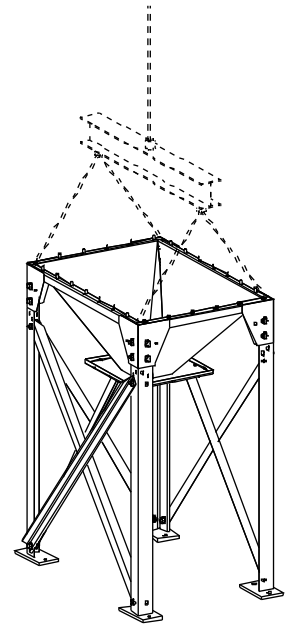

angle not to exceed 30° from vertical (min 60° from horizontal)



Do Not lift with this orientation

Apply sealant after marriage of hopper to cabinet

-
- 3/8-16 x 1 1/4-in bolt
 - 3/8-in flat washer
 - sealant
 - module flange
 - module flange
 - 3/8-in flat washer
 - 3/8-in lock washer
 - 3/8-16 hex nut

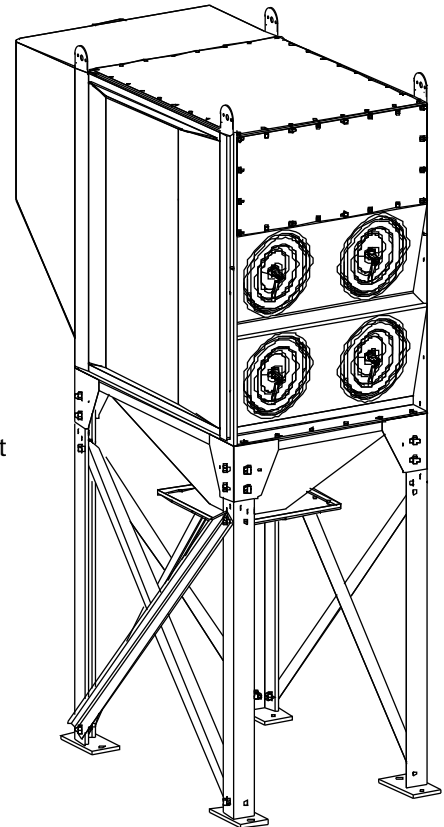

Typical Installation

Standard Equipment

Standard equipment consists of modules, hoppers, and legs. The legs and hopper are assembled first and the unit is placed using a crane. Collectors with up to seven modules require one crane for installation and units containing eight or more modules require two cranes.

Field Assembly

Field assembly of modules may be required due to truck capacity, crane capacity, or specific customer requirements. A detailed instruction drawing, shipped with each module, provides specific assembly and lifting instructions.

If unit has been shipped with fully-assembled modules, skip to Hopper Installation.

Leg and Hopper Installation

There are five hopper styles offered for the Downflo Oval. A single-module wide that spans two portholes, a single-module wide that spans three portholes, a double-module wide spanning four portholes, a tall steeper, single-module wide module which spans two portholes, and a single-module screw conveyor spanning two portholes. All styles except the screw conveyor transition to a single 10-in square discharge. The screw conveyor hopper transitions to a single 18-in square discharge.

Leg sets are designed for standard height collectors and are rated as shown in the Rating and Specification Information. Reference the drawing shown below and the leg assembly drawing shipped with the leg set for proper location and assembly.

1. Stand the hopper on the discharge end.
2. Use drift pins to align holes.
3. Reference the Leg Positioning and Leg and Cross Brace Assembly drawings. Attach the legs to the hopper gussets using the hardware supplied.
4. Join multiple hoppers together at hopper gussets using the hardware supplied. Do not tighten hardware at this time.

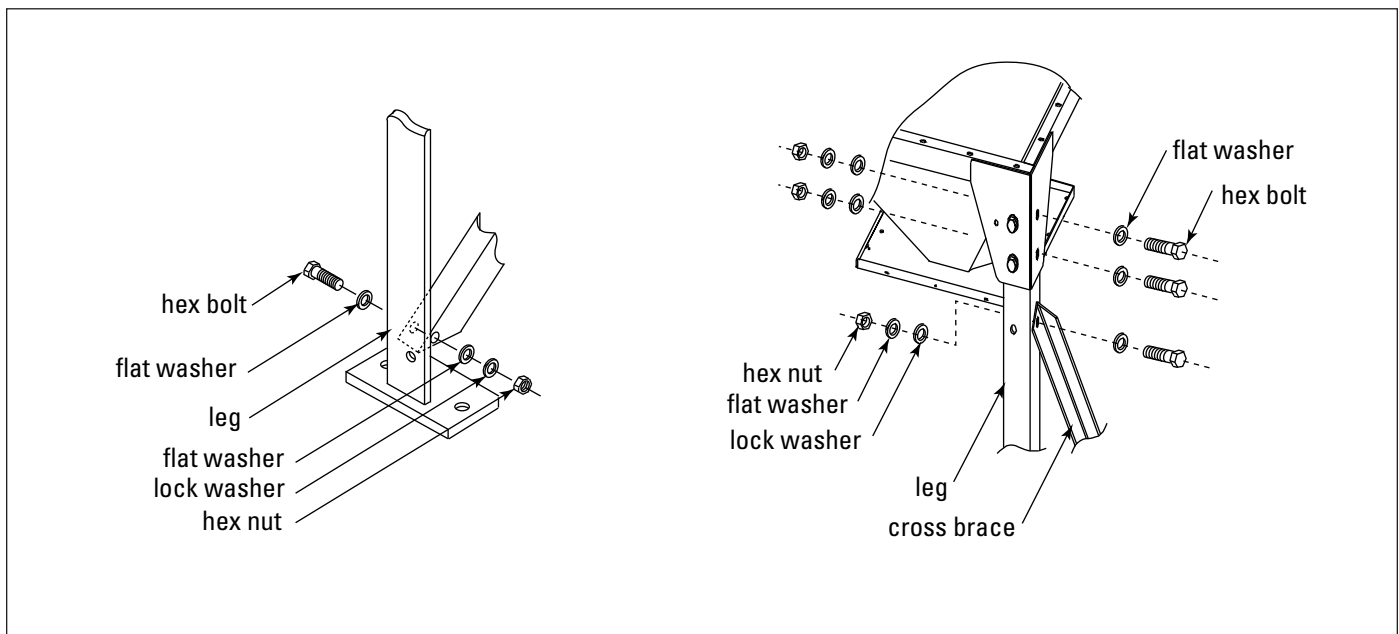

Leg and Cross Brace Assembly

5. Turn leg and hopper assembly over and position over anchor bolts. Secure each leg pad to the foundation anchor bolts with customer-supplied flat washers, lock washers, and nuts. Do not tighten hardware at this time.
6. Level hopper.
7. Tighten all hardware securing legs, cross braces, hopper gussets, and foundation anchor bolts.

NOTICE Tighten all hardware before removing crane.

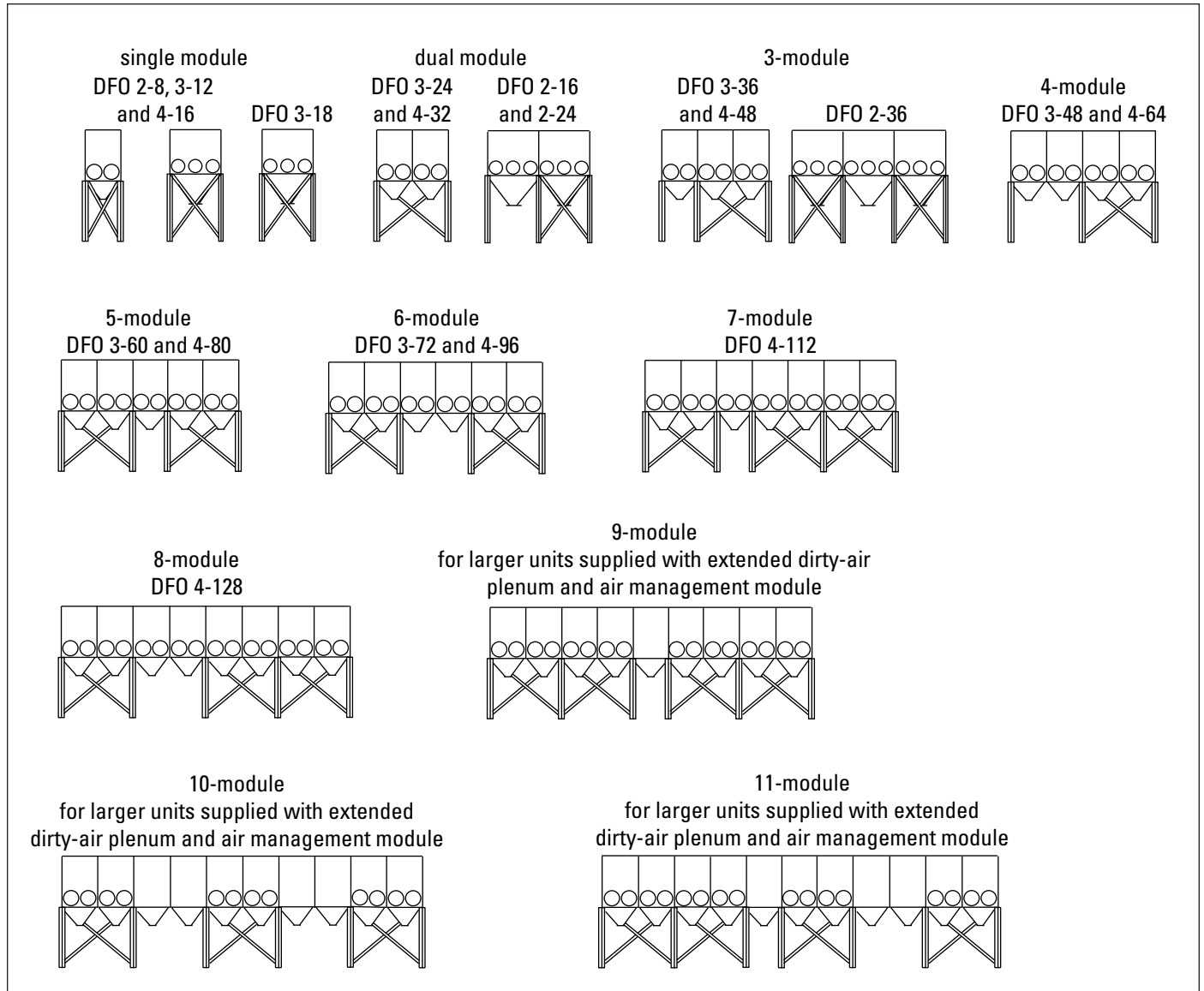

Leg Positioning

Module Assembly

NOTICE

Two cranes are required to lift and assemble modules.

1. Remove the protective cover from the end of each module.
2. Remove one column of access covers, filters, venturis, yokes, and deflector panels from the joint-side of each module. See Detail A.
3. Remove outlet cover from the bottom of the clean-air plenum and set aside.
4. Apply a generous amount of sealant to one module to create an airtight seal between the clean- and dirty-air plenums as shown in Detail B.
5. Lift both modules into position using two cranes.
6. Use drift pins to align the bolt holes in the mating flanges.

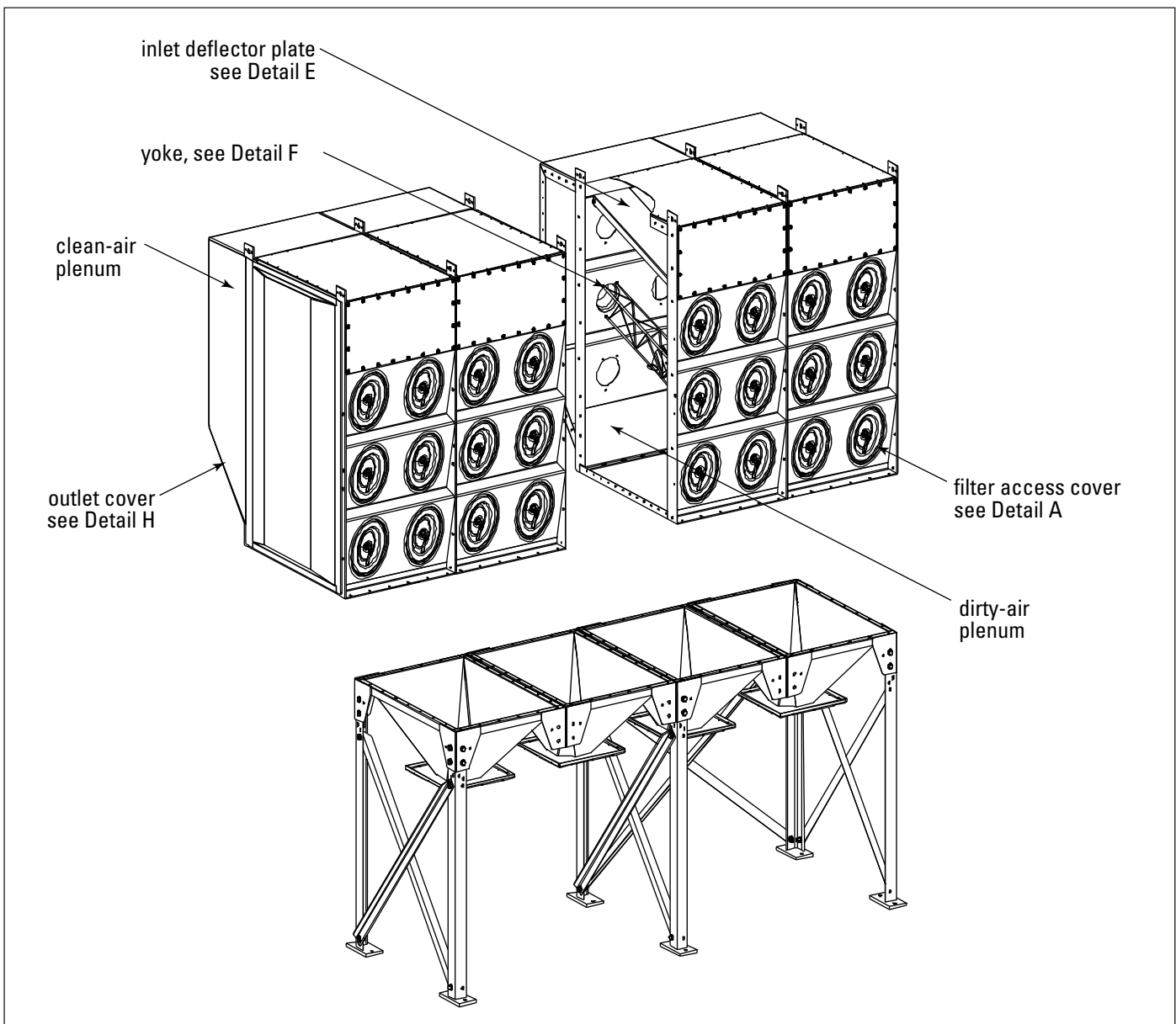

Module Assembly

7. Bolt the modules together using 1/2-13 and 3/8-16 x 1 1/4-in bolts, washers, and nuts as shown Details B, C, and D. Do not tighten hardware at this time.

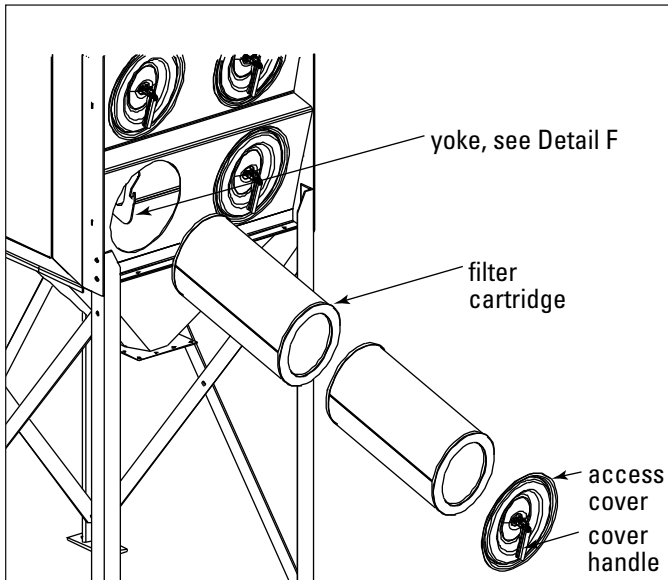

Detail A

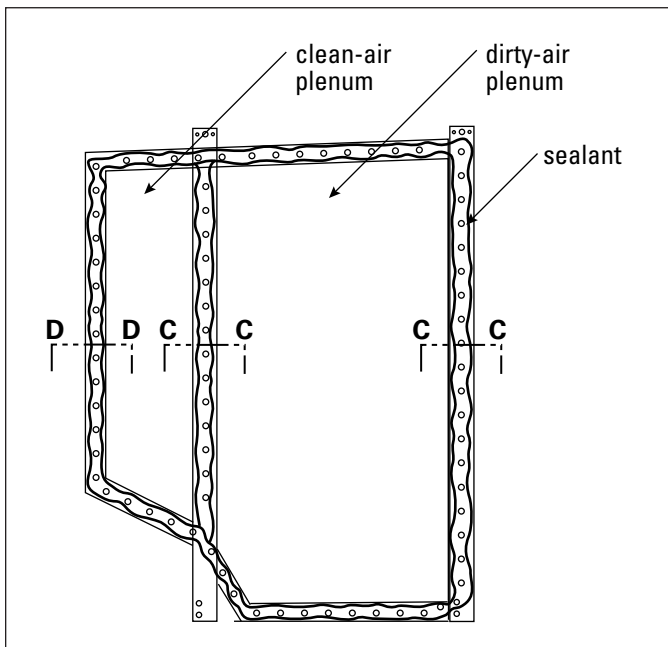

Detail B

8. Check that all joints and flanges are flush and tighten hardware starting with the joint between the clean- and dirty-air plenums. Remove excess sealant.

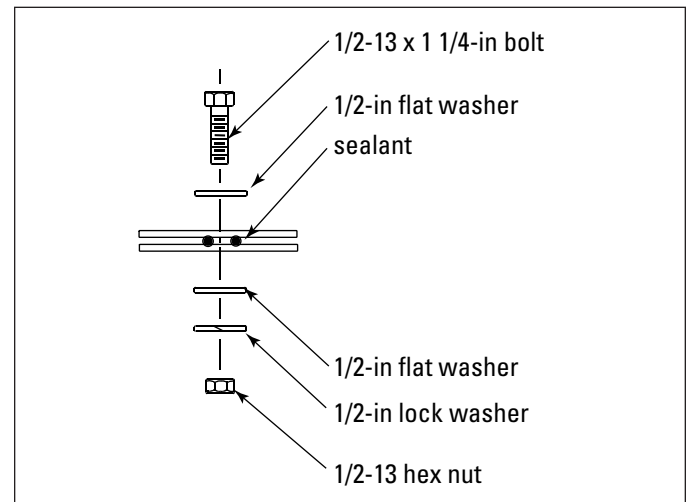

Detail C

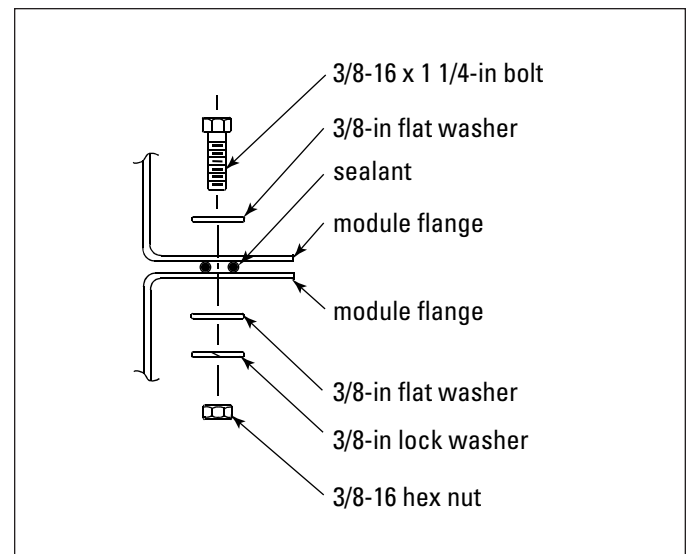

Detail D

Deflector Plate, Yoke, Venturi, and Filter Installation

NOTICE

Installing yokes requires two people.

1. Attach deflector plates to the support angles using 3/8-16 x 1 1/4-in bolts, washers, and nuts as shown in Detail E.
2. From the clean air plenum (to access, remove the outlet cover, see Detail H), thread a thin jam nut to the shoulder of each of the two yoke rod ends. See Detail G and H.
3. Start at the top access port and work downward. Position the yoke as shown in Detail F. From the filter section, have one person hold the yoke in position while another person installs the venturi and hardware from the clean-air plenum. See Detail H. Do not tighten hardware at this time.
4. Adjust jam nut against the filter cartridge panel. Have one person hold the yoke in position as shown in Detail F while another person tightens the three hex nuts from the clean-air plenum (see Detail H). Repeat to install all yokes.
5. Slide the filter cartridge on the yoke gasket-end first. Replace access cover and tighten securely by hand. Repeat for all filter cartridges.
6. Replace the outlet cover on the bottom of the clean-air plenum. See Detail H.

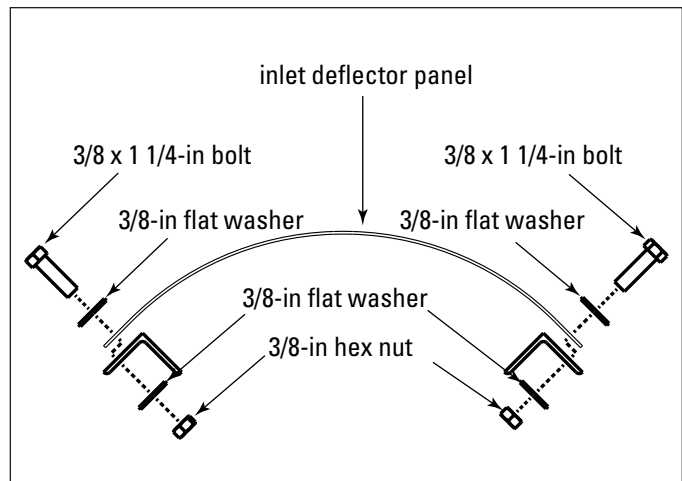

Detail E

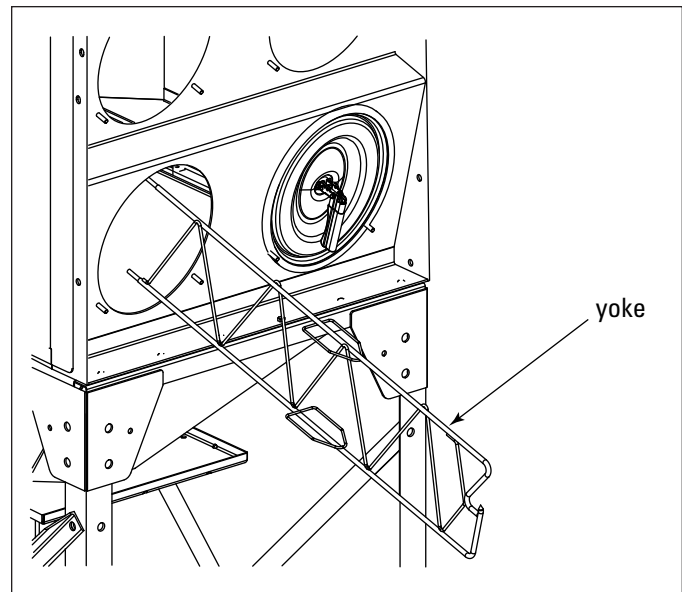

Detail F

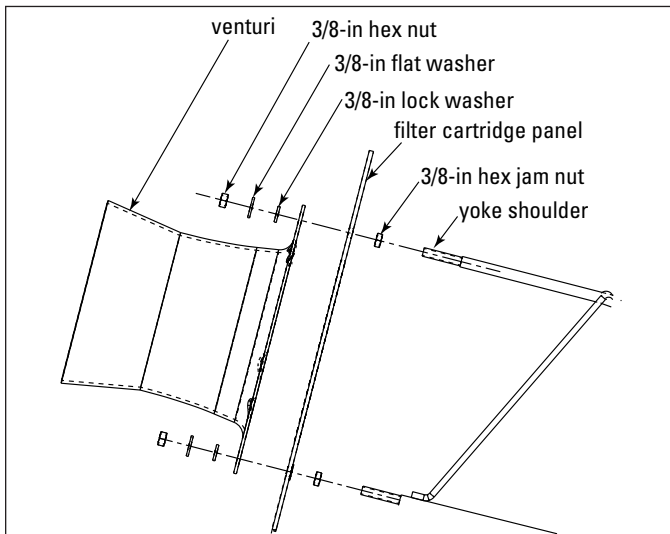

Detail G

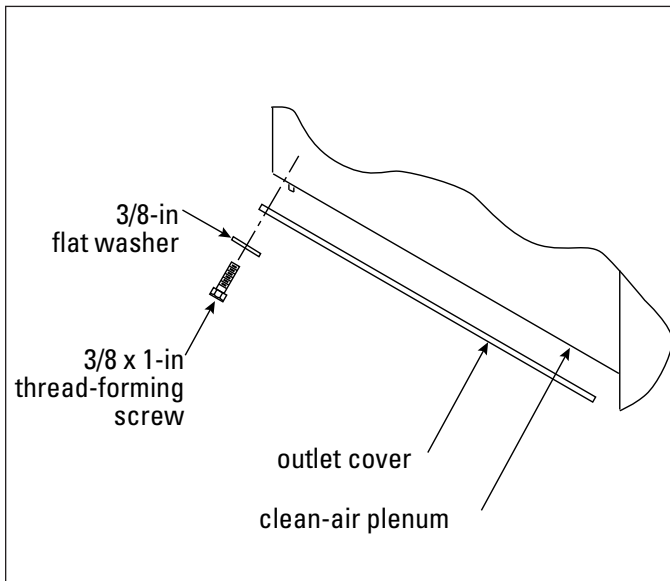

Detail H

Compressed Air Installation

WARNING

Turn compressed-air supply OFF and bleed lines before performing service or maintenance work.

A safety exhaust valve should be used to isolate the compressed air supply. The safety exhaust valve should completely exhaust downstream pressure when closed and include provisions to allow closed-position locking.

NOTICE

Do not set compressed-air pressure above 100-psig.

Component damage can occur.

All compressed air components must be sized to meet the maximum system requirements of 90-psig supply pressure.

The compressed-air supply must be oil and moisture free. Contamination in the compressed air used to clean filters will result in poor cleaning, cleaning valve failure, or poor collector performance.

Purge compressed-air lines to remove debris before connecting to the unit's compressed-air manifold.

1. Remove the plastic pipe plug from the unit's air manifold and connect the compressed-air supply line. Use thread-sealing tape or pipe sealant on all compressed-air connections.
2. Install a customer-supplied shut-off valve, bleed-type regulator with gauge, filter, and automatic condensate valve in the compressed-air supply line

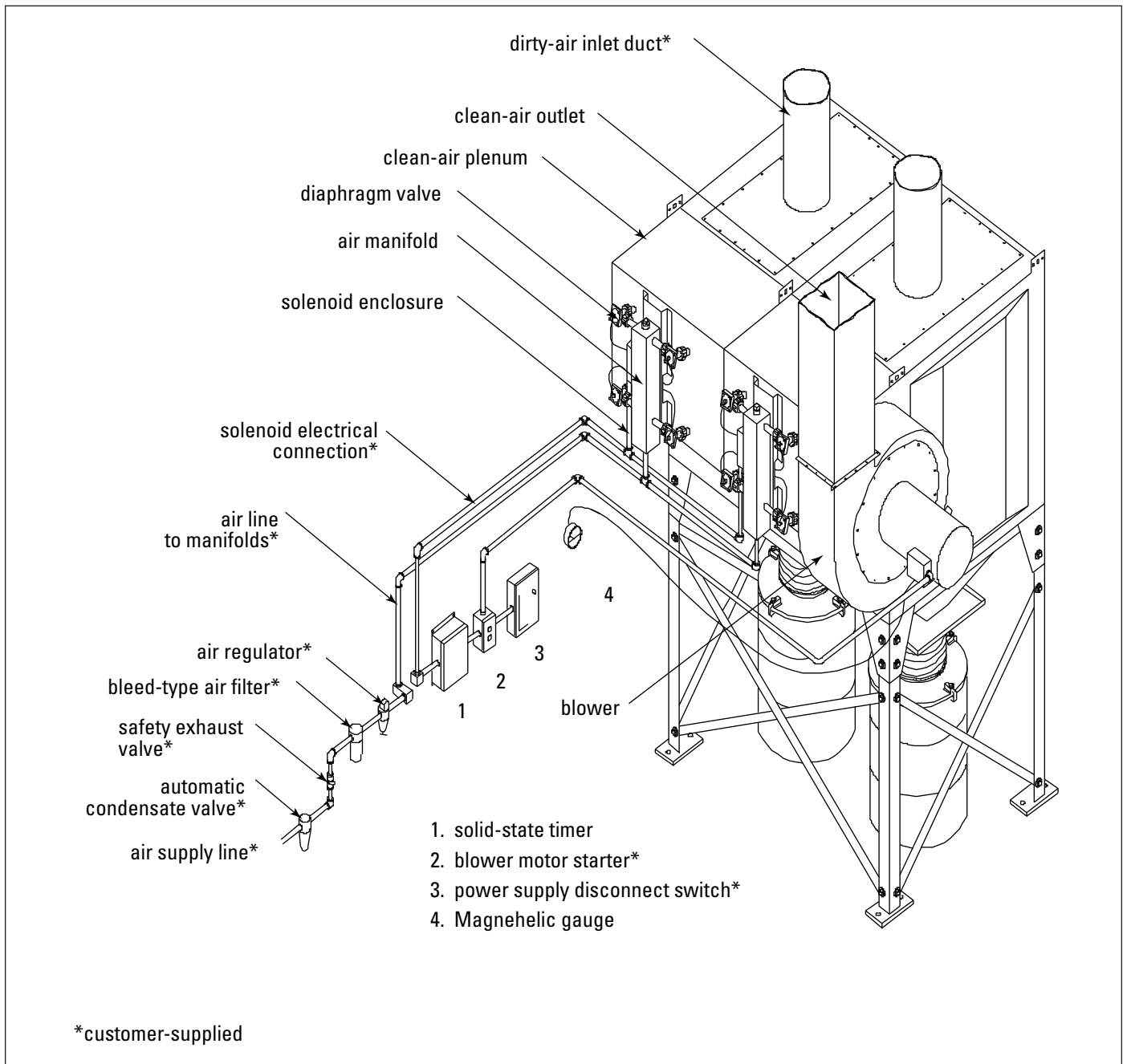

Compressed Air and Component Installation

Solid-State Timer Installation

WARNING

Electrical installation must be performed by a qualified electrician and comply with all applicable national and local codes.

Turn power off and lock out electrical power sources before performing installation, service, or maintenance work.

Do not install in classified hazardous atmospheres without an enclosure rated for the application.

The solid-state timer is an electronic timer used to control the filter cleaning system. Available options include 3, 6, 10, 20, and 32-pin solenoid valve control.

1. Using the supplied wiring diagram, wire the fan motor, fan-motor starter, solid-state timer, and solenoid valves. Use appropriate wire gauge for rated amp load as specified by local codes.
2. Plug the program lug into the pin that corresponds with the number of solenoid valves controlled.
3. With power supply ON, check the operation of the solenoid valves. The valves should open and close sequentially at factory set 10-second intervals.
4. If a Photohelic gauge or similar device is used to control the solid-state timer and the jumper on the pressure switch portion of the timer is removed, the solenoid valves pulse only when the differential pressure reaches the high-pressure setpoint. The valves continue to pulse until the low-pressure setpoint is reached.

NOTICE

The solid-state timer requires a 220-Volt customer-supplied power supply.

Do not mount the solid-state timer directly to the unit. Mechanical vibration can damage the control.

Solenoid Connection

The unit is equipped with 220-V solenoid valves that control the pulse-cleaning valves, which clean the filters.

One of three types of solenoid enclosures, the weatherproof NEMA 4 with 3D2 solenoids, the explosion proof NEMA 7 with 5D2 solenoids, or the explosion proof NEMA 9 with 5D2 solenoids, is mounted near or on the unit's compressed-air manifold.

Wire the solenoids to the solid-state timer following the wiring diagram supplied with the unit. Filter life and cleaning operation will be affected if not wired correctly.

Timer and Solenoid Specifications

Power to the solid-state timer is supplied to Terminals L1 and L2, which operate in parallel with the fan starter's low-voltage coil. On fan start-up, power is supplied to the timer and the preset OFF time is initiated. At the end of the OFF time, the timer energizes the corresponding solenoid valve to provide the ON time cleaning pulse for one diaphragm valve and then steps to the next until all filters have been cleaned.

To pulse when the fan is OFF, install a toggle switch as shown on the Solid-State Timer Wiring Diagram. When the toggle switch is ON, the timer receives power and energizes the solenoid valves' pulse-cleaning operation even though the fan is turned OFF.

Input
200/240V/50-60Hz

Output Solenoids
The load is carried and turned ON and OFF by the 200 watt maximum-load-per-output solid-state switch.

Pulse ON Time
Factory set at 100-milliseconds, or 1/10-second.

NOTICE Do not adjust pulse ON time unless the proper test equipment is available. Too much or too little ON time can cause shortened filter life.

Pulse OFF Time
Factory set at 10-seconds, adjustable from 1 to 1.5-second minimum to maximum 60 to 66-second.

Operating Temperature Range
-20° F to 130° F

Transient Voltage Protection
50 kW transient volts for 20-millisecond duration once every 20 seconds, 1% duty cycle.

Solenoid Valves
220-Volt at 23.1 watts each

Compressed-Air
Set compressed-air supply at 90-psig. The timer is factory set to clean one filter or set of filters every 10-seconds.

NOTICE Do not set compressed-air pressure above 100-psig. Component damage can occur.

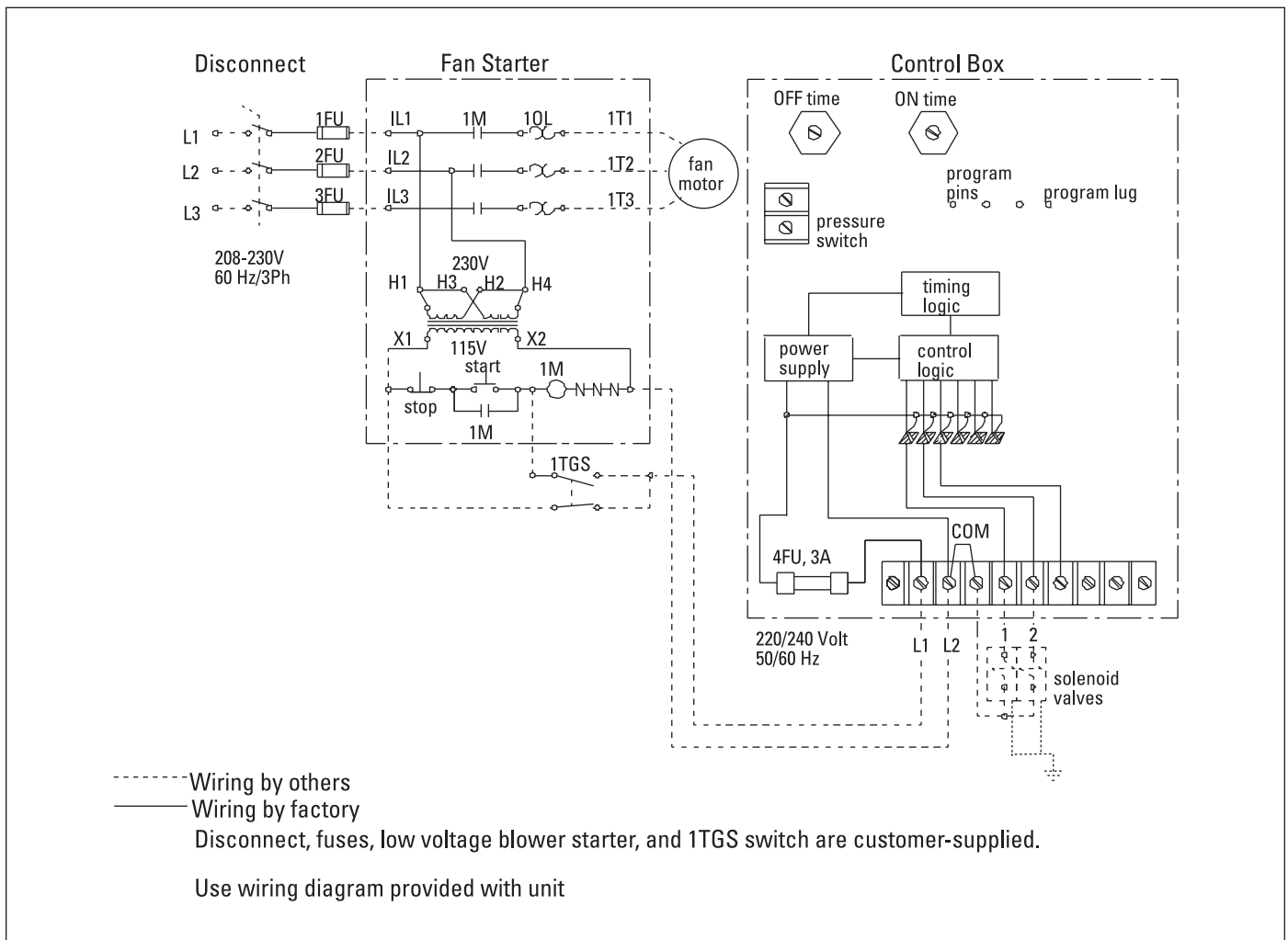

Solid-State Timer Typical Wiring Diagram

Preliminary Start-Up Check

Instruct all personnel on safe use and maintenance procedures.

WARNING Electrical work during installation must be performed by a qualified electrician and comply with all applicable national and local codes.

Turn power off and lock out electrical power sources before performing service or maintenance work.

Turn compressed air supply OFF and bleed lines before performing service or maintenance work.

Check that the collector is clear and free of all debris before starting.

Do not install in classified hazardous atmospheres without an enclosure rated for the application.

Optional fans over 600 lbs must be independently supported.

1. Check all electrical connections for tightness and contact.
2. Motor and fan should be wired for clockwise rotation when viewed from the back of the motor.

To reverse rotation, single-phase power supply:
Follow manufacturer's instructions on the motor's nameplate.

To reverse rotation, three-phase power supply:
Turn electrical power OFF at source and switch any two leads on the motor junction box.

WARNING Do not interchange a power lead with the ground wire. Severe damage or personal injury may result.

3. All access panels should be sealed and secure.
4. Check that the dust container is properly sealed and clamped.
5. Check that exhaust damper is set to the fully-closed position.
6. Check and remove all loose items in or near the inlet and outlet of the unit.

7. Check that all remote controls and solenoid enclosures (if applicable) are properly wired and all service switches are in the OFF position.
8. Check that all optional accessories are installed properly and secured.
9. Turn power ON at source.
10. Turn the compressed-air supply ON. Adjust pressure regulator for 90-100 psig.
11. Turn blower fan motor ON.

WARNING Do not look into fan outlet to determine rotation. View the fan rotation through the back of the motor.
Check that the exhaust plenum is free of tools or debris before checking blower/fan rotation.
Stand clear of exhaust to avoid personal injury.

12. Adjust airflow with the exhaust damper.

NOTICE Excess airflow can shorten filter life, cause electrical system failure, and blower motor failure.

This Page Intentionally Left Blank

Maintenance Information

Instruct all personnel on safe use and maintenance procedures.

WARNING

Use proper equipment and adopt all safety precautions needed for servicing equipment. Electrical service or maintenance work must be performed by a qualified electrician and comply with all applicable national and local codes.

Turn power off and lock out electrical power sources before performing service or maintenance work.

Do not install in classified hazardous atmospheres without an enclosure rated for the application.

Turn compressed air supply OFF and bleed lines before performing service or maintenance work.

NOTICE

Do not set compressed-air pressure above 100-psig.

Component damage can occur.

All compressed air components must be sized to meet the maximum system requirements of 90-100 psi supply pressure.

The compressed-air supply must be oil and moisture free. Contamination in the compressed air used to clean filters will result in poor cleaning, cleaning valve failure, or poor collector performance.

Purge compressed air lines to remove debris before connecting to the unit's compressed air manifold.

Operational Checklist

1. Monitor the physical condition of the collector and repair or replace any damaged components.

Routine inspections will minimize downtime and maintain optimum system performance. This is particularly important on continuous-duty applications.

Periodically check the compressed air components and replace compressed air filters.

Drain moisture following the manufacturer's

instructions. With the compressed air supply ON, check the cleaning valves, solenoid valves, and tubing for leaks. Replace as necessary.

2. Monitor pressure drop across filters.

Abnormal changes in pressure drop indicate a change in operating conditions and possibly a fault to be corrected. For example, prolonged lack of compressed air will cause an excess build-up of dust on the filters resulting in increased pressure drop. Cleaning off-line with no flow usually restores the filters to normal pressure drop.

3. Monitor exhaust.

4. Monitor dust disposal.

Filter Removal and Installation

WARNING

Use proper safety and protective equipment when removing

contaminants and filters.

Dirty filters may be heavier than they appear.

Use care when removing filters to avoid personal injury.

Filter Removal

1. Turn power to unit OFF.
2. Start at the top access port.
3. Remove access cover. For units with Bag-In/Bag-Out: remove access cover by lifting latch handle and lifting cover to remove from yoke. For units with Bag-In/Bag-Out: lift up access cover handle and while pushing in on cover, slide access cover to the side 1-inch to remove access cover.

If the access cover clamp fails to operate smoothly, apply WD-40® to the riveted pivot points and to the clamp rod where it passes through the outside of the cover. Wipe off overspray.

4. Break the seal between the filter cartridge and the sealing surface.
5. Slide the filter out the access port along the suspension yoke and dispose of properly.

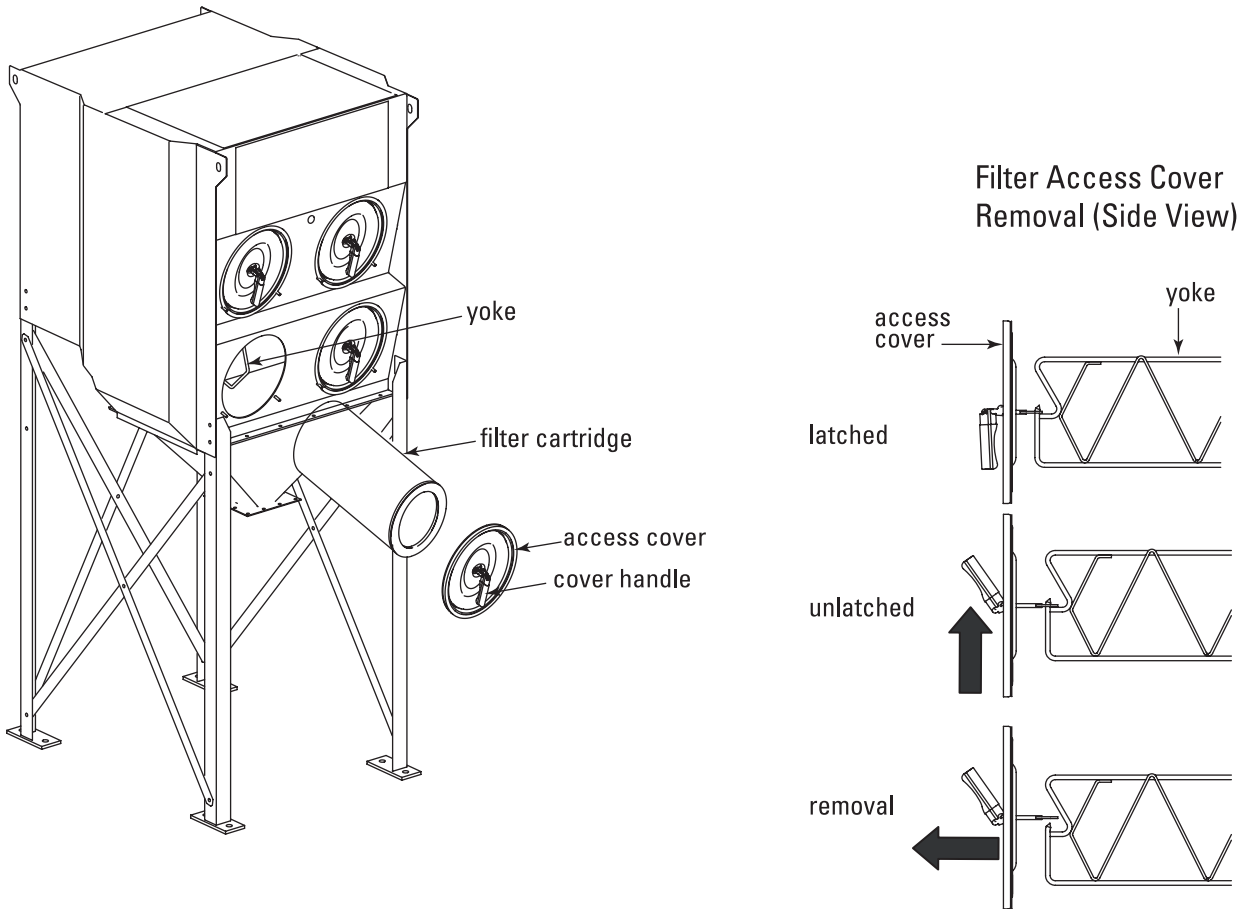

Optional and Bag-In/Bag-Out Filter Access Cover Removal (Top View)

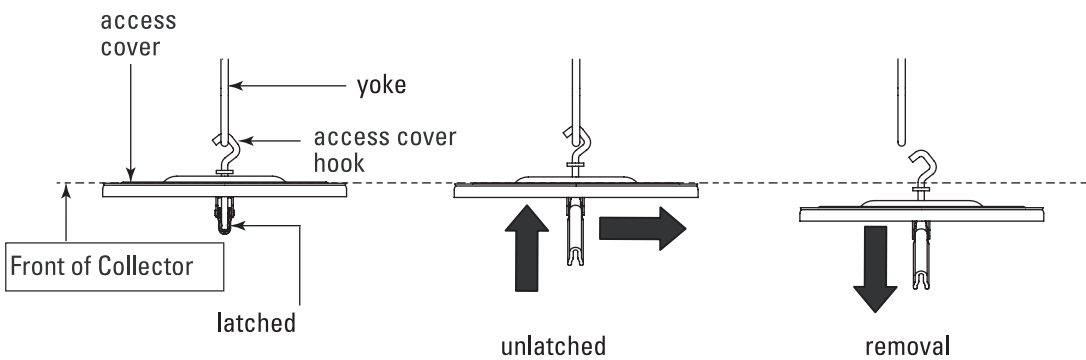

Filter Replacement
(This type of access cover used for APAC ex.G.C.)

6. Clean the sealing surface with damp cloth.

NOTICE

Clean dust from gasket sealing area to ensure a positive filter gasket seal.

7. Check for an accumulation of dust in the storage area and empty as necessary.

Filter Installation

1. Slide the new filter cartridges onto each suspension yoke.

Note: Insert the filter, gasket end first.

2. Wipe cover gaskets clean and replace covers by attaching cover to yoke hook and firmly latching cover handle.

Replace access covers carefully by securing them using the handle provided. Keep fingers away from the sealing surface to avoid pinching.

NOTICE

Check that access covers are seated and seal properly.

Gaskets must be compressed to ensure an airtight seal.

3. Turn electrical power and compressed air supply ON before starting unit.

Dust Disposal

1. Turn unit OFF and empty dust container as necessary to minimize dust in the hopper.
2. If the optional 55-gallon drum attachment is used, empty when drum is 2/3 full.
3. If optional slide gate is used, close gate before servicing drum.
4. Reinstall drum and open gate (if applicable).

Compressed Air Components

NOTICE

Do not set compressed-air pressure above 100-psig.

Component damage can occur.

1. Periodically check the compressed air components and replace compressed-air filters.
2. Drain moisture following the manufacturer's instructions.
3. With the compressed-air supply ON, check the cleaning valves, solenoid valves, and tubing for leaks. Replace as necessary.

This Page Intentionally Left Blank

Optional Equipment

Power Pack From DCI

The two types of power packs, Torit Backward Inclined, TBI, and Torit Radial Blade, TRB, are installed following the same procedure. Both can be ordered for top or side mount.

1. The power packs are shipped assembled and partial disassembly is required before installing.
2. Remove eight motor-mount bracket fasteners; remove the motor, motor-mount bracket, and fan wheel as an assembly as shown.
3. Turn housing over and apply sealant to the outside-edge of the bolt pattern on the fan housing. Mount the fan housing to the collector using the inlet cone fasteners.

Note: For a top-mounted TBI, or a TRB with a blast-gate style damper, install a spacer ring between the fan housing and the collector to provide the necessary clearance for the damper installation.

For top-mount TBI with explosion vent, install the spacer spool between the blower housing and the collector to provide the necessary clearance for explosion vent and weather dome. Position of the blower fan housing should not restrict explosion vent opening.

4. Apply sealant to the outside edge of the bolt pattern on the fan housing. Reinstall the motor, bracket, and fan wheel assembly. Align motor mount bracket to the mark on the housing on 30 Hp, 60 Hz, and 20-30 Hp, 50 Hz units. Other motor sizes do not require alignment, but consider the electrical connection location.

5. Rotate fan wheel after installation to ensure proper clearance between the inlet cone and the fan wheel.



Do not allow the fan wheel to come loose from the motor as it

may cause severe injury or property damage. To ensure proper attachment of the fan wheel:

Tighten all setscrews in fan wheel.*

Tighten all setscrews in bearings.*

Repeat after 8 hours of operation.

Repeat again after two weeks of operation.

Reference Wheel Setscrew Torque Table.

Setscrew Size Diameter	Carbon Steel Setscrew Torque*	
	Lb. - In.	Lb. - Ft.
1/4	75	6.2
5/16	144	12
3/8	252	21
7/16	396	33
1/2	600	50
5/8	1164	97
3/4	2016	168
7/8	3204	267
1	4800	400

*Stainless steel setscrews are not hardened and should not be tightened to more than half of the values shown.

Wheel Setscrew Torque

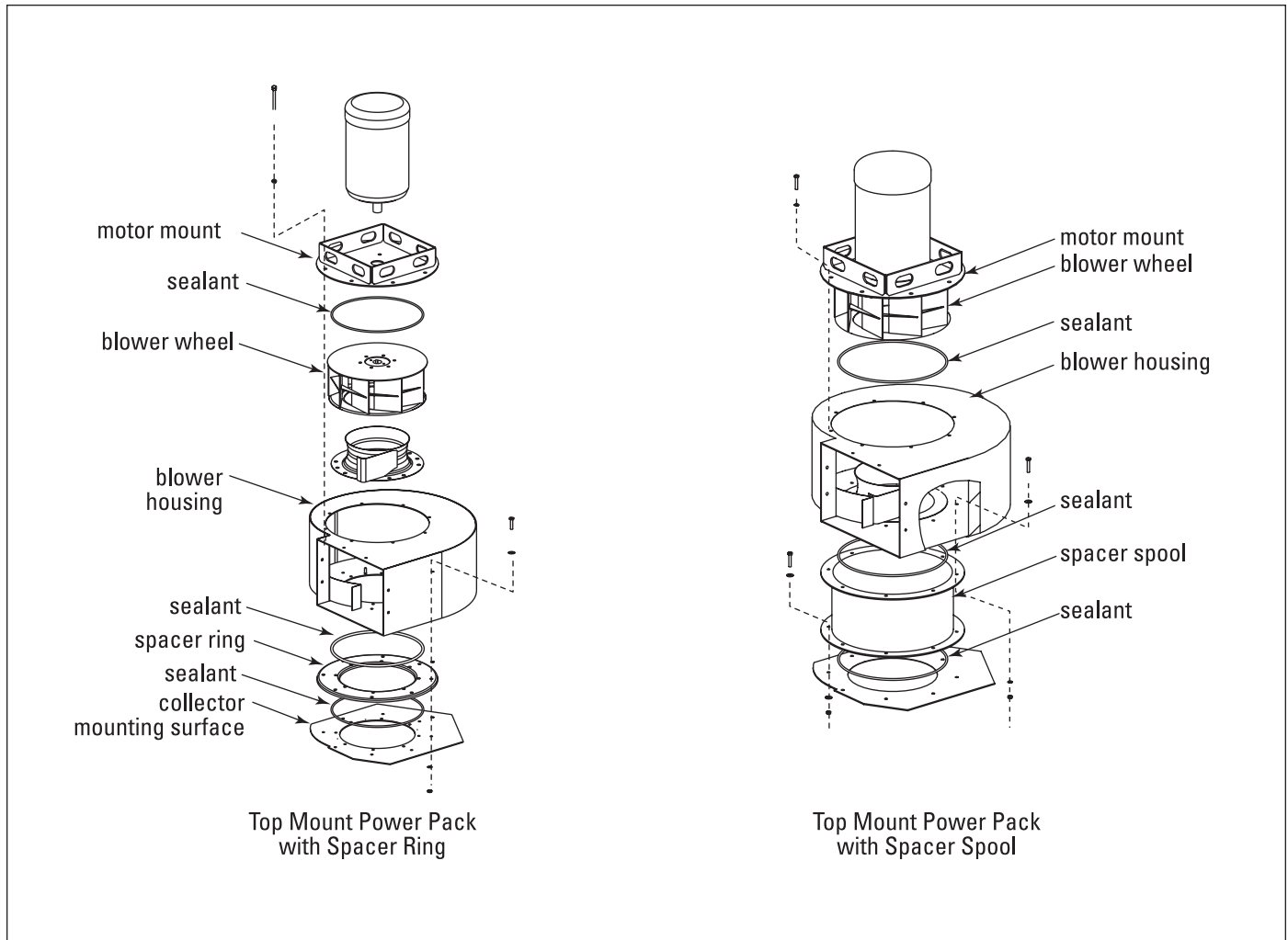

Power Pack, TBI with Spacer Ring and TBI with Spacer Spool for Explosion Vented Units

Power Pack From Europe (K fan Series)

Add the picture of the K fan.

The type of power pack are installed on top of dust collector.

1. The power pack is shipped assembled and partial disassembly is required before installing.
2. Remove eight motor-mount bracket fasteners; remove the motor, motor-mount bracket, and fan wheel as an assembly as shown.
3. Turn housing over and apply sealant to the outside-edge of the bolt pattern on the fan housing. Mount the fan housing to the collector using the inlet cones fasteners.
4. Apply sealant to the outside edge of the bolt pattern on the fan housing. Reinstall the motor, bracket, and fan wheel assembly. Align motor mount bracket to the mark on the housing.
5. Rotate fan wheel after installation to ensure proper clearance between the inlet cone and the fan wheel. Do not allow the fan wheel to come loose from the motor as it may cause severe injury or property damage.

Side-Mount Power Pack Only for TBI and TRB (for Units Built After July 2003)

WARNING

Electrical work must be performed by a qualified electrician and comply with all applicable national and local codes.

Turn power off and lock out electrical power sources before performing service or maintenance work.

Do not install in classified hazardous atmospheres without an enclosure rated for the application.

CAUTION

Mounting a power pack on the side of a collector requires a side power adapter to support the weight of the power pack.

Poorly installed power packs may separate from the collector resulting in personal injury and damage to equipment or property.

1. Disconnect power supply.
2. Apply 1/4-in diameter rope-type sealant to the outside surface of the power adapter between the fan mount bolt holes and the round fan inlet hole.
3. Install the fan housing to the power adapter using 3/8 x 1 1/4-in bolts, flat washers, and hex nuts.

NOTICE

Install bolts with the bolt head in the fan housing and the threaded end in the power adapter.

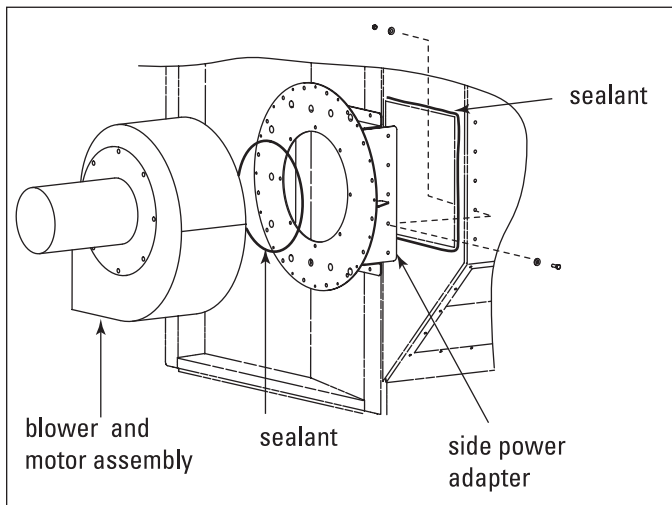

Side-Mount Power Pack Field Installation

4. Install the motor and blower assembly to the fan housing using the original hardware and caulk sealant.
5. Connect power supply to the motor. Turn the fan motor ON then OFF to check motor rotation by referencing the rotation arrow on the blower.

To reverse rotation, three-phase power supply:
Turn electrical power OFF at source and switch any two leads on the motor junction box.

WARNING

Do not interchange a power lead with the ground wire. Severe damage or personal injury may result.

55-Gallon Drum Pack

The drum pack is designed to fit a customer-supplied, standard 55-gallon drum and provides easy access for dust removal and disposal. A flexible hose connects the drum cover and slide gate, or drum cover and adapter. Placing a pallet under the drum allows heavier product to be moved quickly using a forklift or pallet jack. If a pallet is used, the length of flexible hose may need to be shortened.

With Slide Gate

1. Place the 1/8-in gasket spacer between the hopper flange and slide gate as shown.
2. Attach the drum pack and slide gate to the hopper flange using 3/8-16 bolts, washers, and hex nuts.
3. Attach the drum cover to the 55-gallon drum.
4. Use latches to secure the cover to the drum, if equipped.
5. Connect the flexible hose between the drum cover and slide gate. Secure with hose clamps.

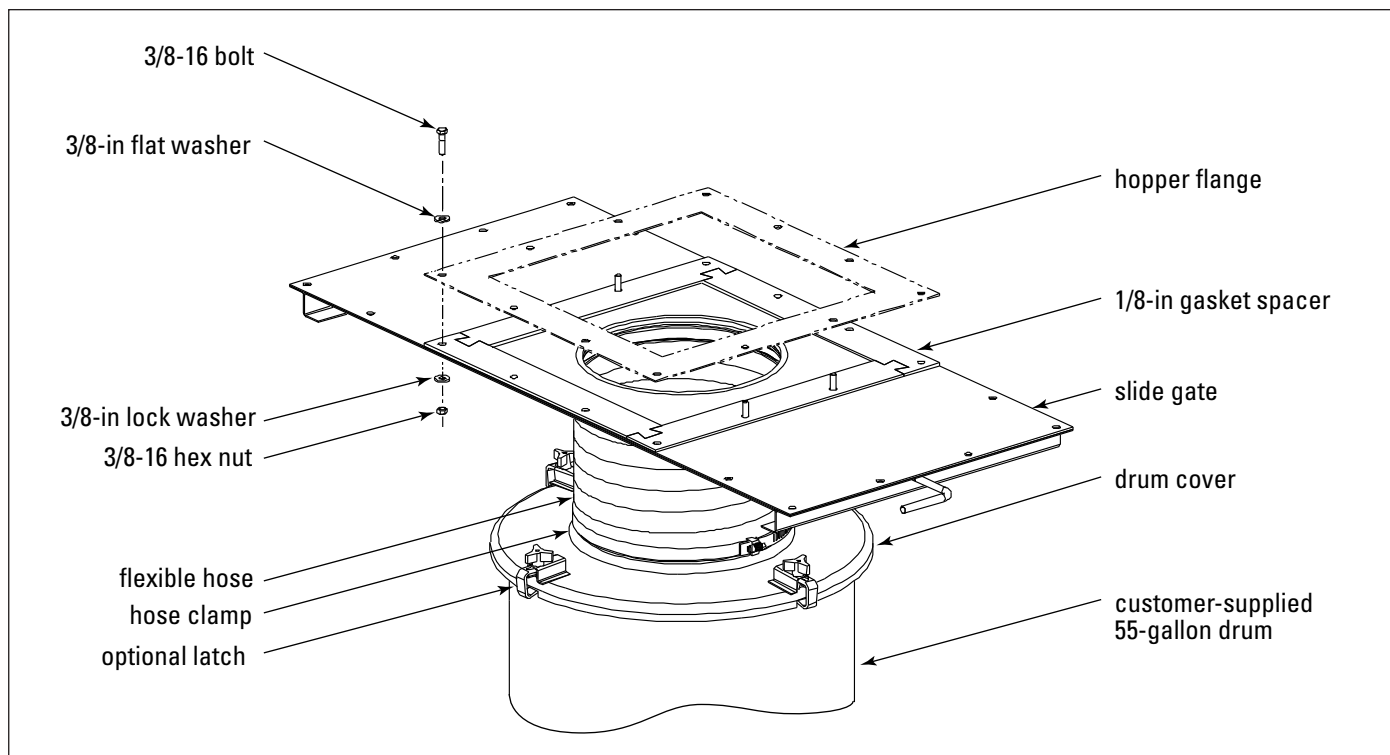

55-Gallon Drum Pack with Slide Gate

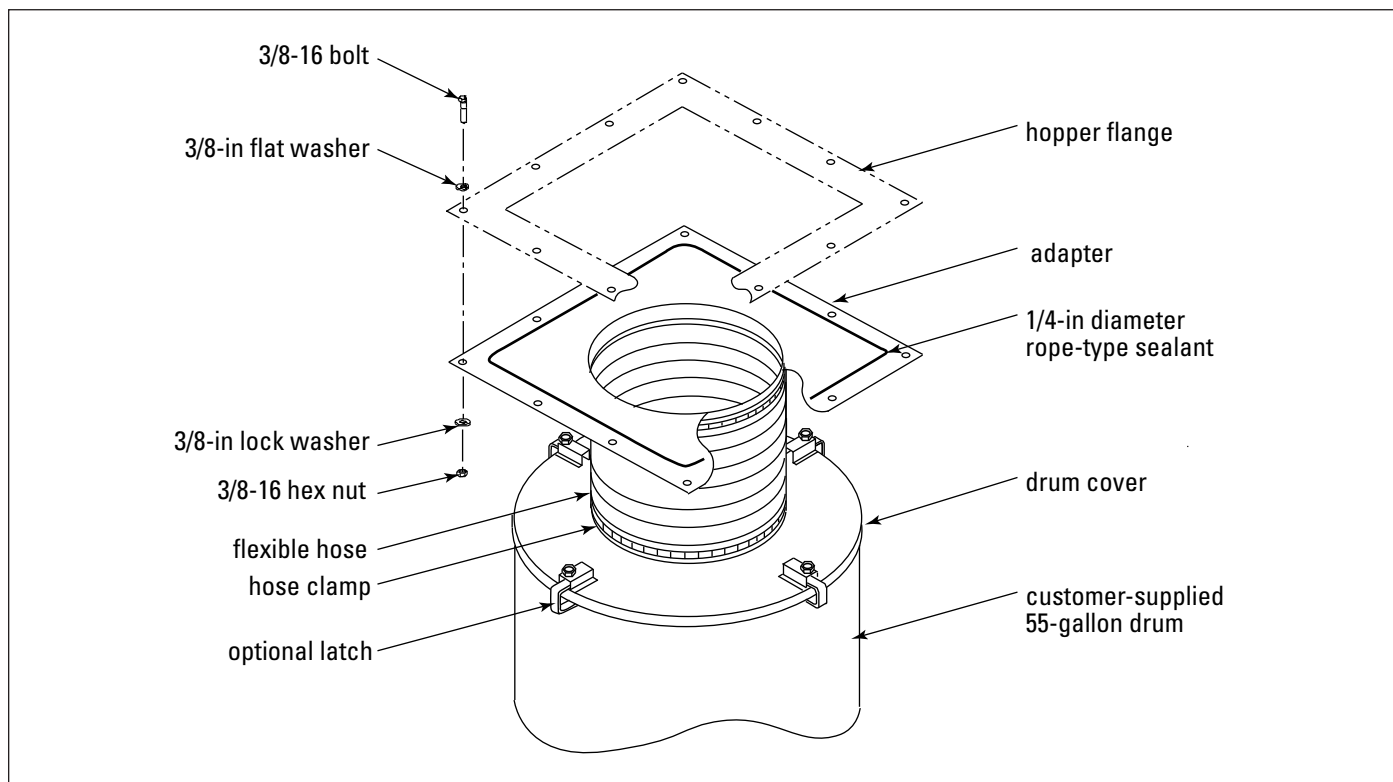

55-Gallon Drum Pack without Slide Gate

Without Slide Gate

1. Place 1/4-in diameter, rope-type sealant between the hopper flange and the adapter as shown.
2. Attach the adapter to the hopper flange using 3/8-16 bolts, washers, and hex nuts.
3. Attach the drum cover to the 55-gallon drum.
4. Use latches to secure the cover to the drum, if equipped.
5. Connect the flexible hose between the drum cover and the adapter. Secure with hose clamps.
2. Plug the pressure ports on the back of the gauge using two, 1/8-in NPT pipe plugs supplied. Install two, 1/8-in NPT male adapters supplied with the gauge into the high- and low-pressure ports on the side of the gauge. Attach the mounting bracket using three, #6-32 x 1/4-in screws supplied.
3. Mount the gauge and bracket assembly to the supporting structure using two, self-drilling screws.
4. Thirty-five feet of plastic tubing is supplied and must be cut in two sections. Connect one section of tubing from the gauge's high-pressure port to the pressure fitting located in the dirty-air plenum. Connect remaining tubing from the gauge's low-pressure port to the fitting in the clean-air plenum. Additional tubing can be ordered from your representative.

Magnehelic Gauge

The Magnehelic is a differential pressure gauge used to measure the pressure difference between the clean- and dirty-air plenums and provides a visual display of filter change requirements. The high-pressure tap is located in the dirty-air plenum and the low-pressure tap is located in the clean-air plenum.

1. Choose a convenient, accessible location on or near the unit for mounting that provides the best visual advantage.
5. Carefully remove the cloth protecting the filters. Close access doors and tighten securely by hand.
6. Zero and maintain the gauge as directed in the manufacturer's Operating and Maintenance Instructions provided.

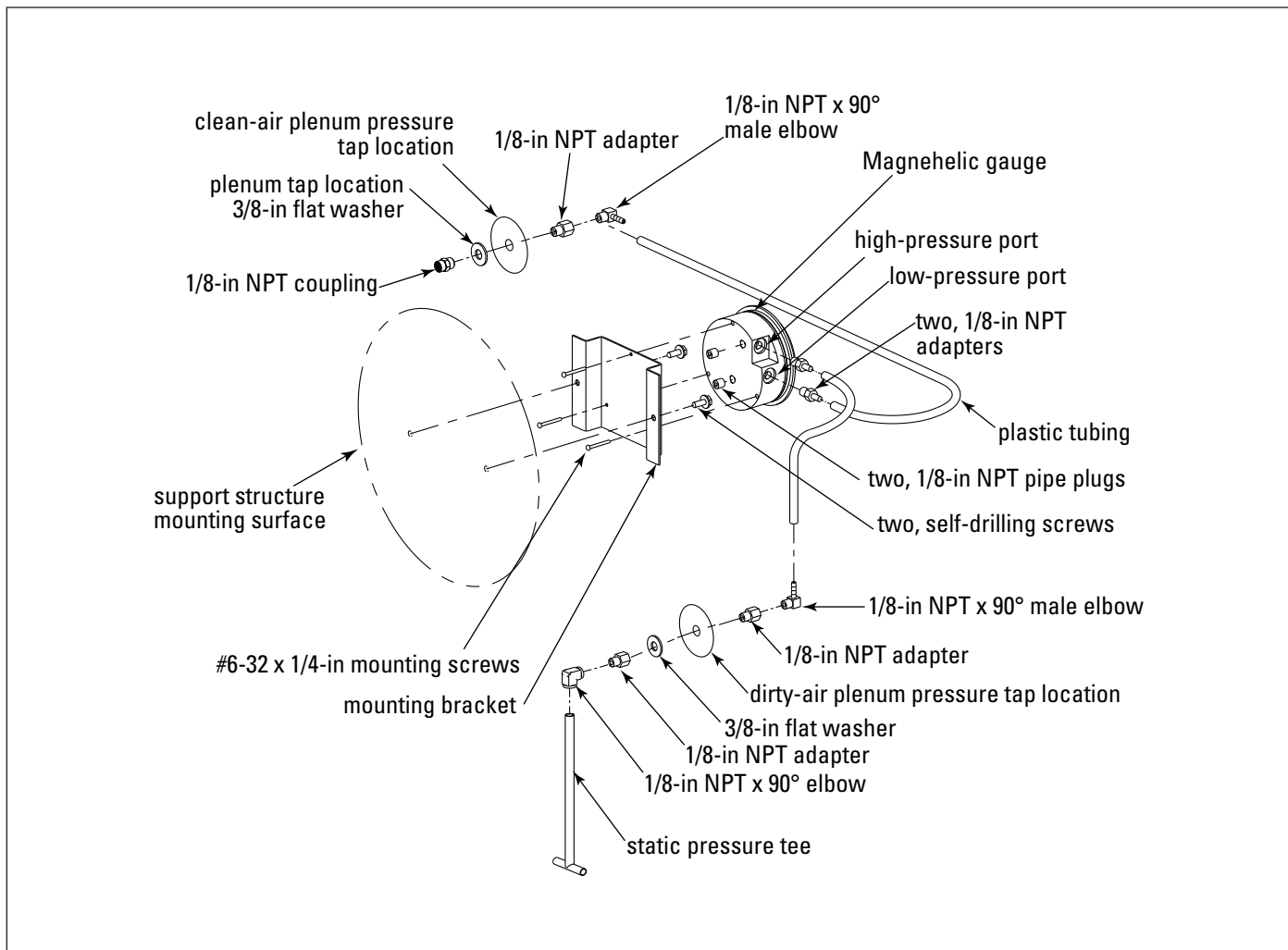

Magnehelic Gauge Installation

Photohelic Gauge

⚠️ WARNING

Electrical work must be performed by a qualified

electrician and comply with all applicable national and local codes.

Turn power off and lock out electrical power sources before performing service or maintenance work.

Do not install in classified hazardous atmospheres without an enclosure rated for the application.

The Photohelic combines the functions of a differential pressure gauge and a pressure-based switch. The gauge function measures the pressure difference between the clean- and dirty-air plenums and provides a visual display of filter condition. The high-pressure tap is located in the dirty-air plenum and a low-pressure tap is located in the clean-air plenum. The pressure-based switch function provides high-pressure ON and low-pressure OFF control of the filter cleaning system.

1. Choose a convenient, accessible location on or near the unit for mounting that provides the best visual advantage.
2. Mount the gauge to the remote panel or door using the mounting ring, retaining ring, and four

#6-32 x 1 1/4-in screws. Do not tighten screws.

Connect two, 1/8-in NPT x 1/4-in OD male adapters to the gauge's high- and low-pressure ports. Tighten screws.

3. On the back of the gauge, remove four #6-32 x 5/16-in screws and plastic enclosure. Set aside. Add two jumper wires supplied by customer. Remove the jumper from the pressure switch located on the timer board, if equipped. Using the 3/4-in conduit opening, wire the gauge as shown. Reassemble and fasten enclosure securely.
4. Thirty-five feet of plastic tubing is supplied and must be cut in two sections. Connect one section of tubing from the gauge's high-pressure port to the pressure fitting located in the dirty-air plenum. Connect remaining tubing from the gauge's low-pressure port to the fitting in the clean-air plenum. Additional tubing can be ordered from your representative.
5. Zero and maintain the gauge as directed in the manufacturer's Operating and Maintenance Instructions provided.
6. To install the Photohelic Gauge mounted in a NEMA 4, Weatherproof Enclosure, follow Steps 4 and 5.

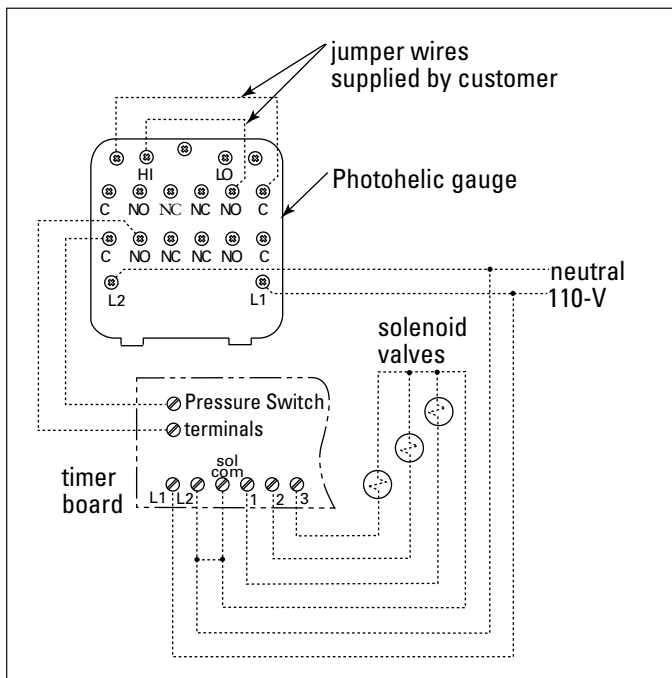

Photohelic Gauge Wiring Diagram

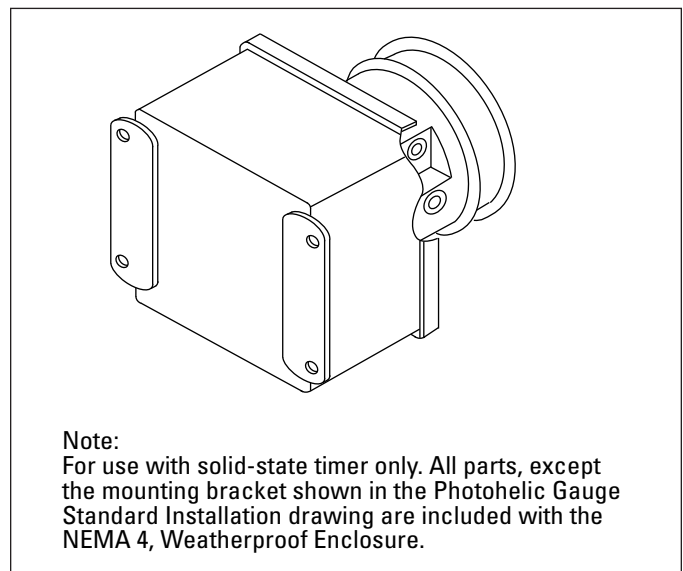

Note:
For use with solid-state timer only. All parts, except the mounting bracket shown in the Photohelic Gauge Standard Installation drawing are included with the NEMA 4, Weatherproof Enclosure.

Photohelic Gauge in Optional NEMA 4 Weatherproof Enclosure

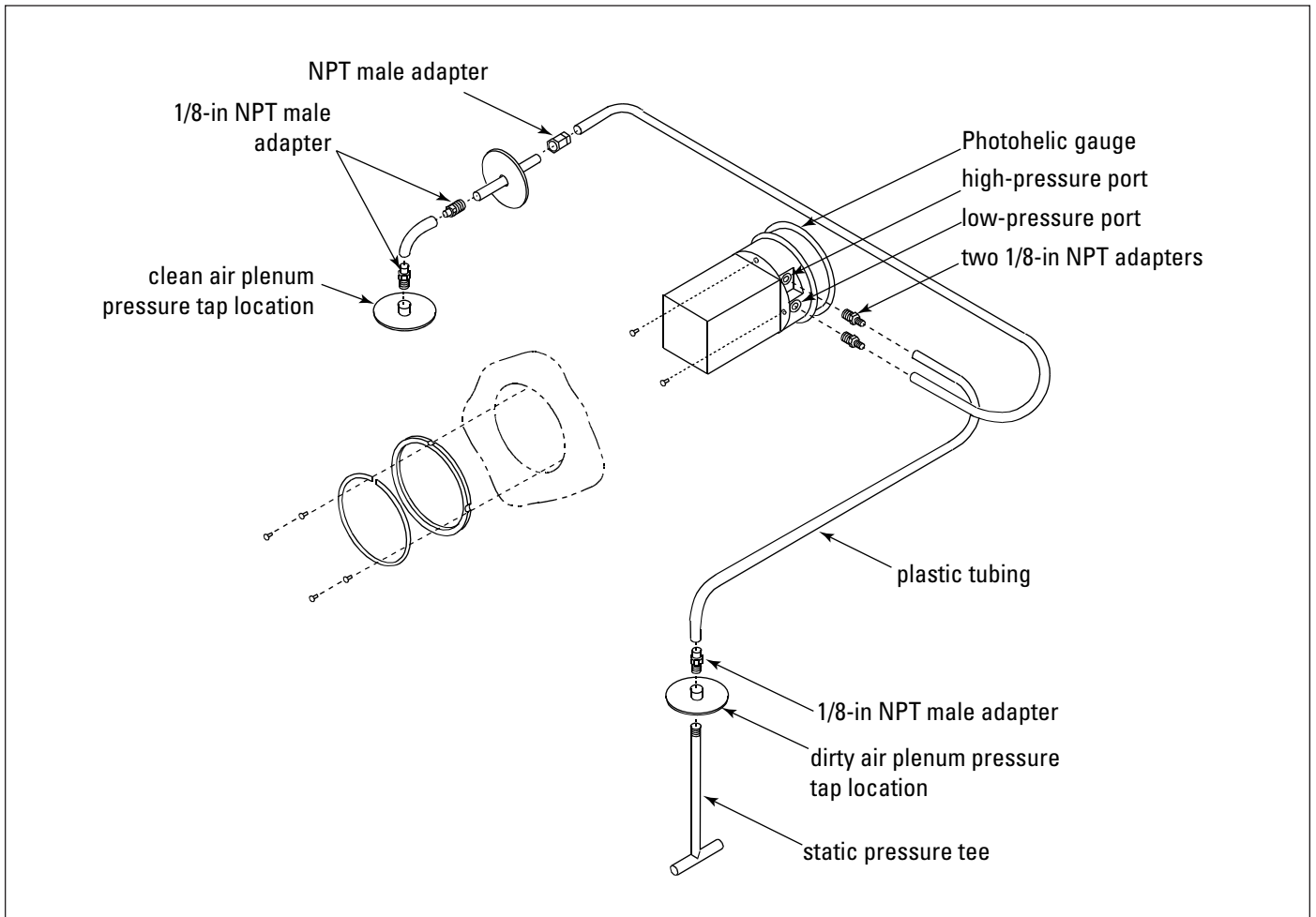

Photohelic Gauge, Remote Panel or Door Installation

Delta P Control

The Delta P Control monitors the differential pressure between the clean and dirty air plenums, providing a visual display of the filter condition. When combined with a pulse timer, it controls the pressure drop by turning the cleaning mechanism On and Off at the chosen limits. There are three (3) set points: High Pressure On, Low Pressure Off, and Alarm. The first two, High Pressure On and Low Pressure Off, control the filter cleaning system. The third, Alarm, provides a relay output to activate an external alarm supplied by others.

Operation

Normal

The Delta P Control monitors the pressure in the clean and dirty air plenums while the unit is running. The blower draws air through the filters, creating a pressure drop. The Delta P control measures the pressure drop and provides a visual display in inches water gauge or metric (SI) units.

Filter Cleaning

When the pressure drop across the filter bags reach the control's High setpoint, the control closes an output relay allowing a timer to trigger the cleaning valves sequentially. When the control senses that the pressure drop has decreased to the Low setpoint, the relay opens and the cleaning cycle stops. This sequence continues as long as the collector is in use, maintaining the pressure drop within a narrow range.

Alarm

The alarm setpoint is set to a higher setting than used to start the filter cleaning cycle. It indicates situations when the cleaning system cannot reduce the pressure drop due to cleaning system failure, lack of compressed air, or the end of the filter's useful life. There is a time delay prior to setting the alarm to prevent nuisance trips. The Delta P Control also provides an input connection for a remote alarm reset.

For complete information, see the most current version of the Delta P Installation, Operation, and Maintenance manual.



Delta P Control Display

Delta P C-01 Control

The Torit Delta P C-01 Controller monitors the differential pressure between the clean and dirty air plenums, providing a visual display of the filter condition. It controls the pressure drop by turning the cleaning mechanism On and Off at the chosen limits. There are three (3) set points: High Pressure On, Low Pressure Off, and Alarm. The first two, High Pressure On and Low Pressure Off, control the filter cleaning system. The third, Alarm, provides a relay output to activate an external alarm supplied by others.

The user can program the Delta P C-01 to pulse while the collector is running to maintain a relatively constant pressure drop across the filters, pulse only after the collector is shut down (after-shift cleaning), or a combination of both, cleaning while running as well as end of shift.

For complete information, see the most current version of the Delta P C-01 Installation, Operation, and Maintenance manual.

Delta P Plus Control

The Delta P Plus Control monitors the differential pressure between the clean and dirty air plenums, providing a visual display of the filter condition. When combined with a pulse timer, it controls the pressure drop by turning the cleaning mechanism On and Off at the chosen limits. There are three (3) set points: High Pressure Drop On, Low Pressure Drop Off, and Alarm. The first two, High Pressure Drop On and Low Pressure Drop Off, control the filter cleaning system. The third, Alarm, provides a relay output to activate an external alarm supplied by others.

The user can program the Delta P Plus Control to pulse while the collector is running, to maintain a relatively constant pressure drop across the filters, pulse only after the collector is shut down (after-shift cleaning), or a combination of both, cleaning while running as well as end of the shift.

Operation

Normal

The Delta P Plus Control monitors the pressure on both sides of the tubesheet while the unit is running. The blower draws air through the filters, creating a pressure drop. The Delta P Plus Control measures the pressure drop and provides a visual display in inches water gauge or metric (SI) units.

Filter Cleaning

The Delta P Plus Control offers three filter cleaning options.

1. **Differential Pressure Cleaning (DFF)** - When the pressure drop across the filters reaches the control's High setpoint, the control closes an output relay allowing a sequential timer to trigger the cleaning valves. When the control senses that the pressure drop has decreased to the Low setpoint, the relay opens and the cleaning cycle stops. This sequence continues as long as the collector is in use, maintaining the pressure drop within a narrow range.
2. **Down Time Cleaning (DTC)** - The Delta P Plus Control monitors the collection system. It watches for the blower to start, the pressure drop to exceed the Low

setpoint, and then for the pressure drop to approach zero. After the blower has come to a stop, the Delta P Plus engages the cleaning mechanism for a pre-selected time.

3. **Combined Differential and Down Time Cleaning (ALL)** - The Delta P Plus Control combines the two functions described above; maintaining the pressure drop in a narrow band and down time cleaning the filters when the collector is shut down. The down time cleaning function can be toggled On or Off from the keyboard.

Alarm

The alarm setpoint is set to a higher setting than used to start the filter cleaning cycle. It indicates situations when the cleaning system cannot reduce the pressure drop due to cleaning system failure, lack of compressed air, or the end of the filter's useful life. There is a time delay prior to setting the alarm to prevent nuisance trips. The Delta P Plus Control also provides an input connection for a remote alarm reset.

For complete information, see the most current version of the Delta P Plus Installation, Operation, and Maintenance manual.



Delta P Plus Control Display

Transition and Rotary Valve

⚠ DANGER

Rotating blades can cause serious injury.

Turn power off and lock out electrical source before performing service or maintenance work.

Keep hands, feet and loose clothing away from both inlet and outlet openings to avoid injury or damage when valve is operating.

The 7-in tall transition is designed to connect a standard hopper and a rotary valve. Rotary valves are used as an airlock and a metering device in dust control applications. When used as an airlock, an airtight seal between the valve's inlet and outlet is maintained while allowing dust or material to pass through. Comparatively, the airlock works along the same line as a revolving door on a building; an airtight seal is maintained while people are allowed to pass through.

When used as a metering device, the valve allows a specific amount of material to pass per revolution,

depending on the size and speed of the valve. Sizing is determined at time of order and based on product load. Standard sizes include 8, 10, 12, and 16-in inlets.

1. Place 1/4-in diameter, rope-type sealant to the inside of the transition's bolt pattern.
2. Use 3/8-16 bolts, washers, and hex nuts to fasten transition to hopper.
3. Determine the proper position required for the rotary airlock. Allow clearance for electrical connections and future maintenance.
4. Place 1/4-in diameter, rope-type sealant toward the inside-edge of the airlock's top flange.
5. Fasten the airlock to the transition flange using 3/8-16 bolts, washers, and hex nuts.
6. Electrical connections must be made by a qualified electrician. Refer to the motor's nameplate for voltage, amp rating, cycle, and wiring sequence.

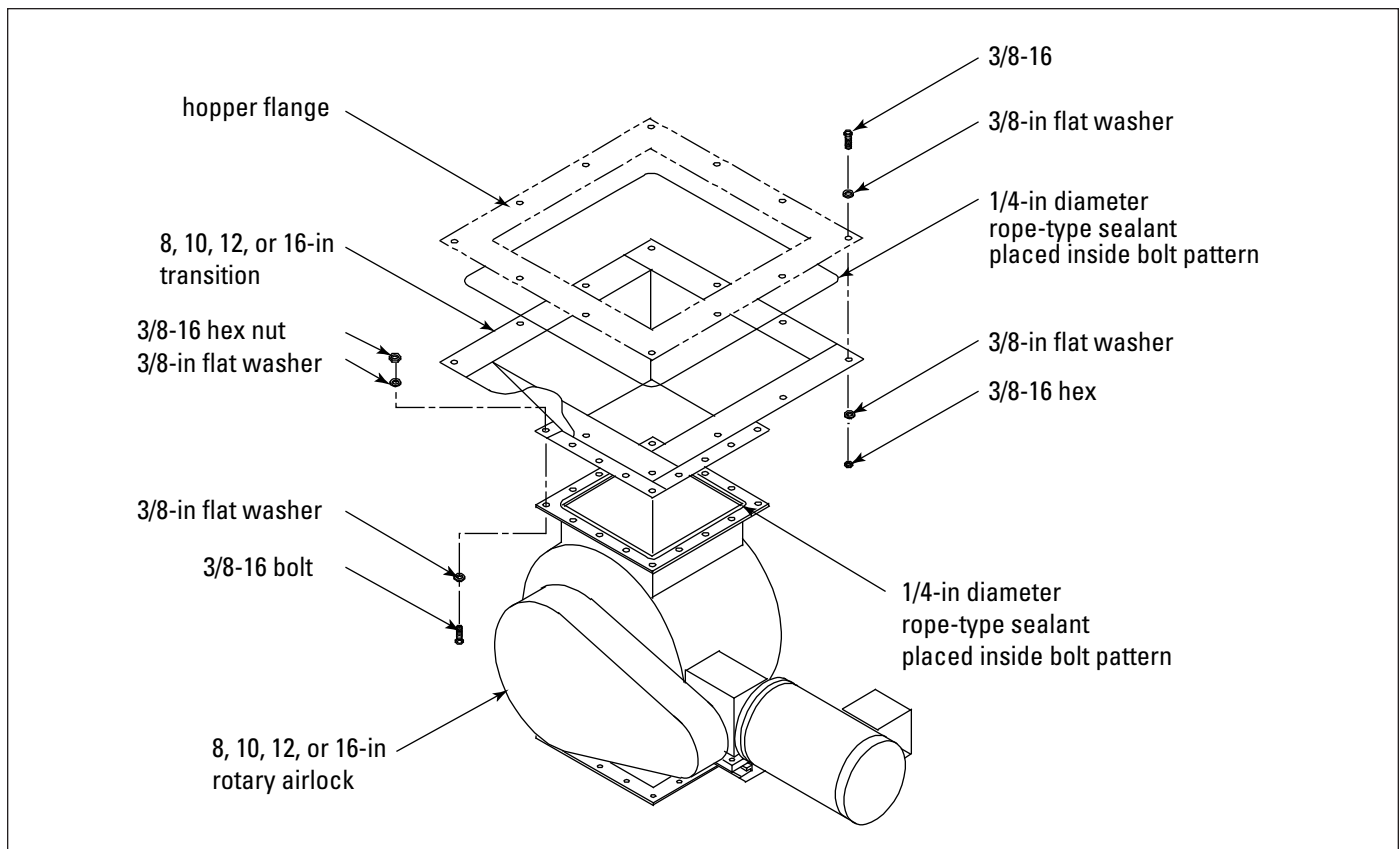

Transition and Rotary Valve Assembly

Damper and Silencer, TBI

Side and Top Mount

1. Install the power pack as described in the previous section.
2. Attach the damper to the fan exhaust outlet using the hardware supplied.
3. Attach the flange to the damper using the bolts, washers, and hex nuts supplied.
4. Apply sealant to the flange and attach silencer to flange. Tighten all hardware.
5. Loosely assemble the silencer's support brackets.
 - a. Align the pivoting support brackets to extend a minimum of 30-in from the collector and mark the drill locations.
 - b. Drill pilot holes with a 0.339-in bit.
 - c. Secure brackets using 3/8-in thread-forming bolts.
6. Loosen the wing nut on the damper and adjust from 30 to 50% closed.

Support Brackets, Top Mount

Support Brackets, Side Mount

- a. Align the support bracket to the underside of the silencer, flush with the cabinet wall and mark the drill locations.
- b. Drill pilot holes with a 0.339-in bit.
- c. Secure brackets using 3/8-in thread-forming bolts.

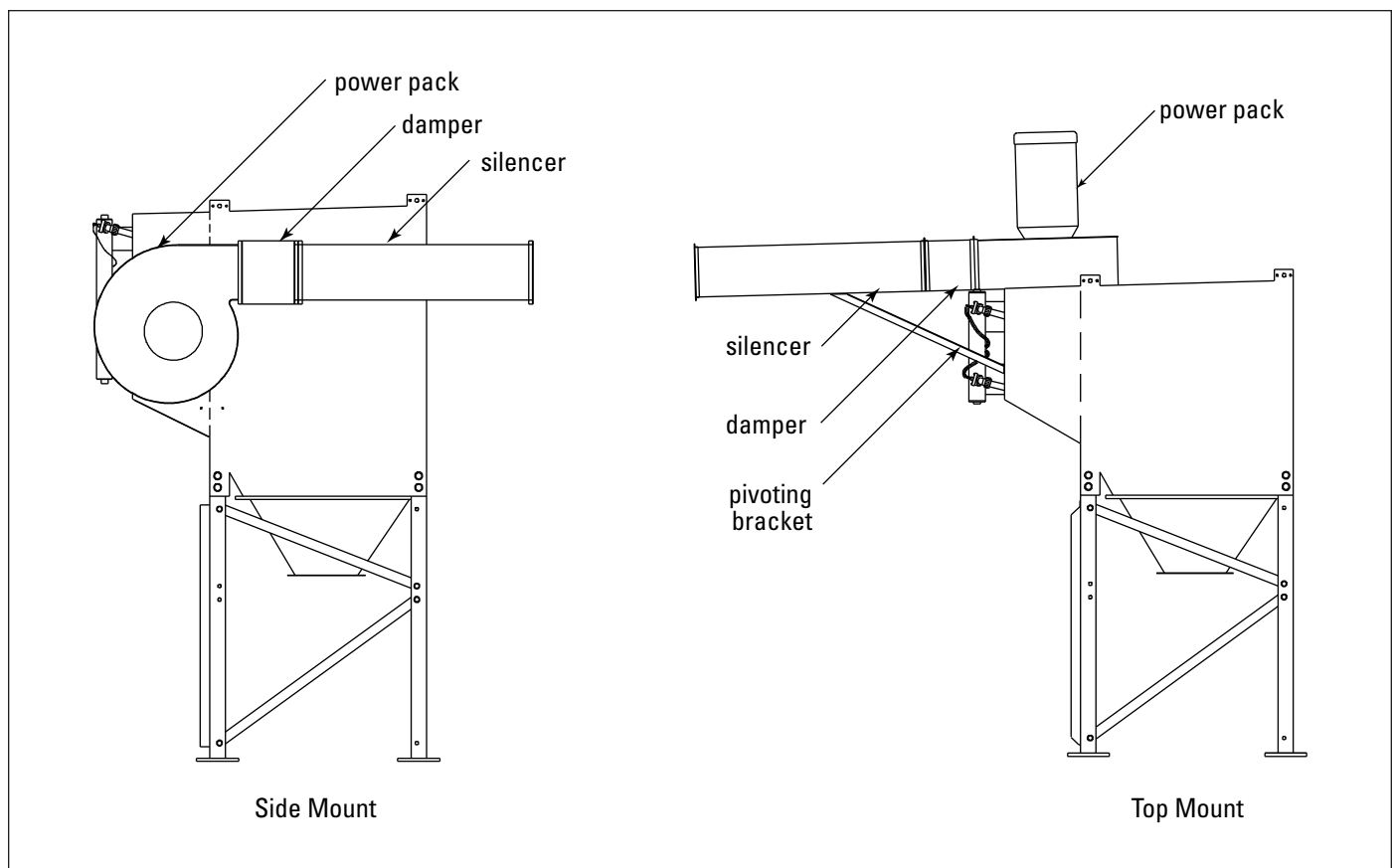

Side and Top-Mount Silencer and Damper Installation

Plenum Silencer, TRB

Top Mount

1. Apply sealant and attach the bottom panel to the collector as described on the assembly drawing shipped with the silencer using a combination of hardware removed from the unit and hardware supplied.
2. Install the fan and motor assembly as described in the Power Pack section and the assembly drawing.
3. Route rigid or flexible conduit from the junction box on the motor to the outside wall of the silencer to house wiring.
4. Install the top of the silencer and attach silencer to base using the supplied hardware.
5. Loosen the wing nut on the damper and adjust from 30 to 50% closed.

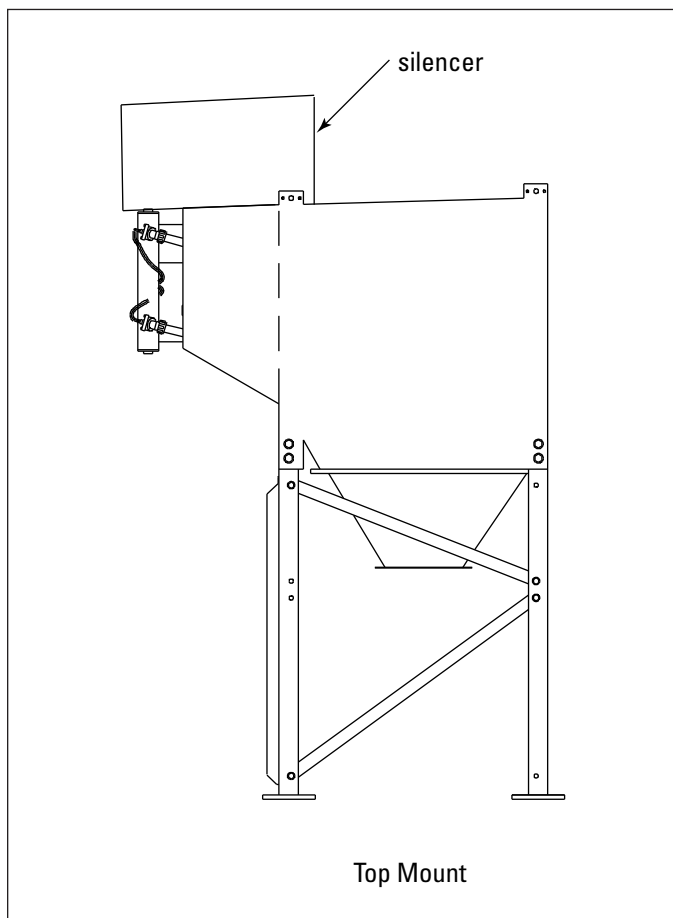

Top-Mount Silencer and Damper Installation

Abrasion-Resistant Inlet Collar

1. Remove the unit's front cover plate. Remove excess sealant from opening.
2. Apply 1/4-in sealant around the opening toward the inside-edge of the bolt pattern.
3. Align the holes on the inlet collar with the holes in the unit and secure using 3/8-16 x 1-in bolts and flat washers supplied.

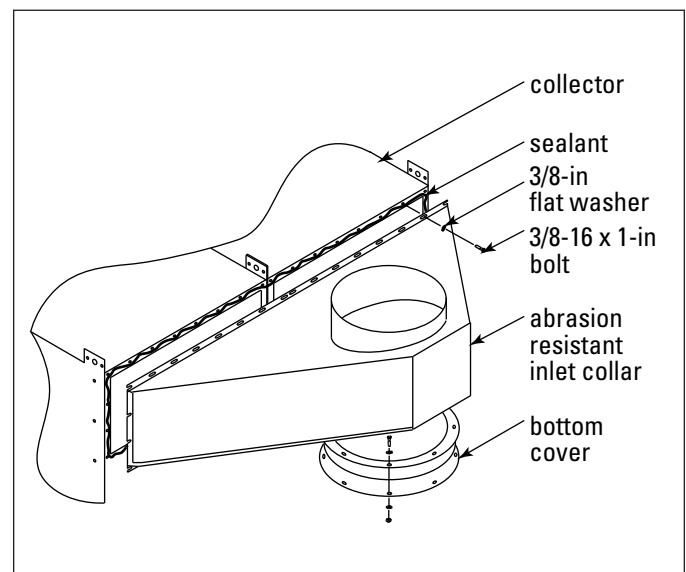

Abrasion-Resistant Inlet Collar

Extended Dirty-Air Plenum

The extended dirty-air plenum is used in applications requiring an air management module, an end inlet, or when a single inlet serves multiple modules.

When positioned as an end module, it is supplied with a standard 24 x 47-in covered opening that may be used as an access or inlet area.

Specify the location of the opening as top, front, or side of the extended dirty-air plenum although front or side locations limit the area to 36 x 36-in.

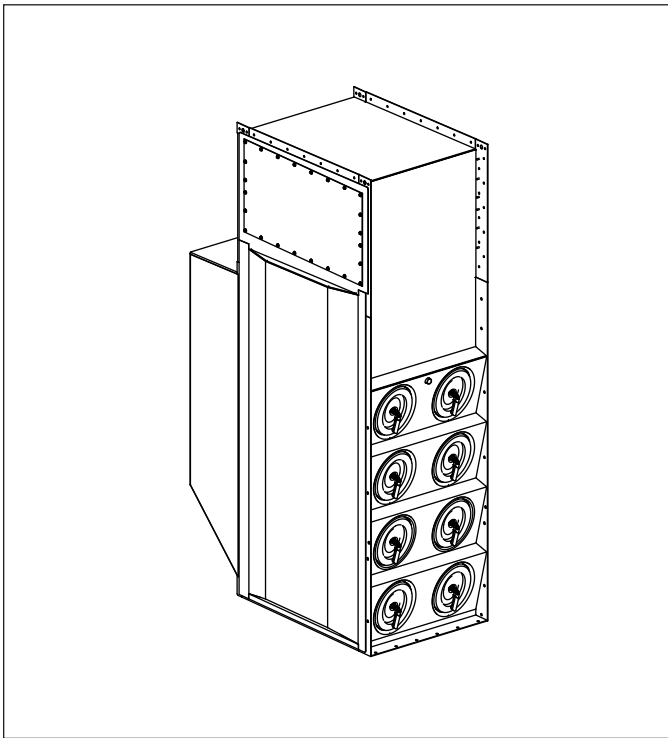

Extended Dirty-Air Plenum

Air Management Module

The air management module is used in applications involving heavy grain loading, large or abrasive particles in the airstream, or in applications when a collector with a single inlet serves multiple modules. It is equipped with a louvered panel near the bottom, which prevents re-entrainment of the dust that falls through to the hopper. This module does not contain filters, and is available for use with an extended dirty-air plenum only.

When the air management module is positioned as an end module, it is supplied with a standard 24 x 27-in covered opening.

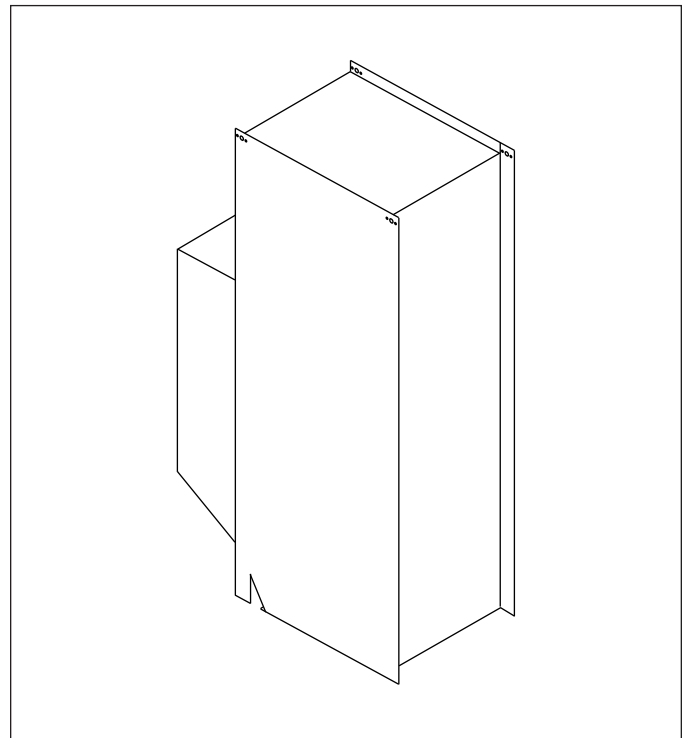

Air Management Module

Platforms and Ladders

Stationary platforms are available for use on single to eleven module, two filter wide units and three module, three filter wide units.

For two filter wide units the platform is available for standard or steep-sided hoppers with the ladder located left, right, or front of the platform.

On three filter wide units the platform is available for standard hoppers only with ladder access on the left or right side only. Complete installation and assembly instructions are shipped with the platform.

CAUTION

Dropping the platform can result in personal injury or property damage. Secure the platform assembly to the crane or forklift with straps or clamps.

Stationary Platform

1. Pre-assemble the platform according to the instructions shipped with the platform. The hardware and placement is called out on the assembly drawing.
2. Lift the assembled platform into position and secure following the assembly drawing instructions.
3. Tighten all hardware before removing crane or forklift.
4. Check platform hardware each time the platform is used.

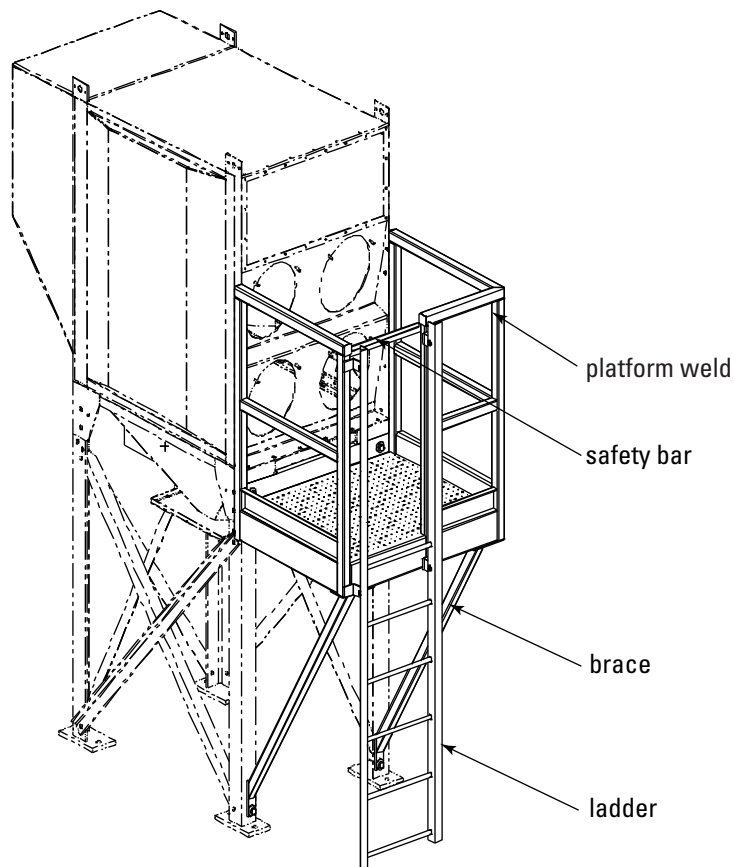

Stationary Platform

Cold Climate Kit

⚠ WARNING

Electrical work during installation must be performed by a qualified electrician and comply with all applicable national and local codes.

Turn power off and lock out electrical power sources before performing service or maintenance work.

A cold climate kit provides heat to the pulse valves to prevent cold weather freeze up. The basic kit, for use in applications that have a moderate amount of moisture in the compressed-air supply, consists of a small heating element and thermostat installed in the solenoid enclosure. The basic kit is factory-installed and supplied with the appropriate solenoid wiring instructions.

A heavy-duty kit is available for applications that have moderate-to-high amounts of moisture in the compressed-air supply and consists of the basic kit plus a heat cable to deliver heat to the large pulse valves. This kit is customer-installed and detailed installation instructions are provided.

1. Install the power connection kit on the heat cable following the manufacturer's instructions.
2. Start with the upper right-hand valve, wrap heat cable around the valve as shown in Detail A. Pull heat cable tight.

NOTICE

Double wrap between round coupling and square valve cover.

3. Position a 3-in hose clamp around the double wrapped heat cable and tighten securely.
4. Wrap remaining valves using the same technique in the order shown in Detail B.
5. Drill a 1-in diameter hole in the back of the junction box. See Detail C. Assemble the power connection kit following the manufacturer's instructions.
6. Secure junction box to manifold using two, 8-in hose clamps wrapped around the standoff.
7. Wrap 6-ft of pipe insulation tape around each heat-cable wrapped valve. Wrap the entire valve, double wrapping the hose-clamped heat cable. Secure with cable ties.

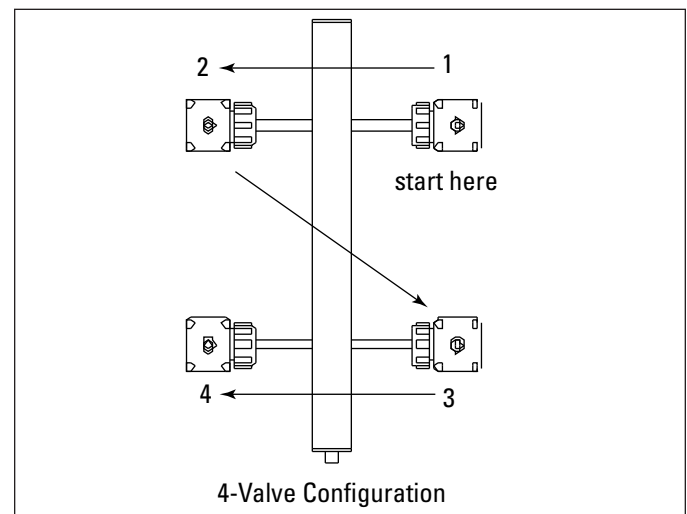

Cold Climate Kit, Detail B

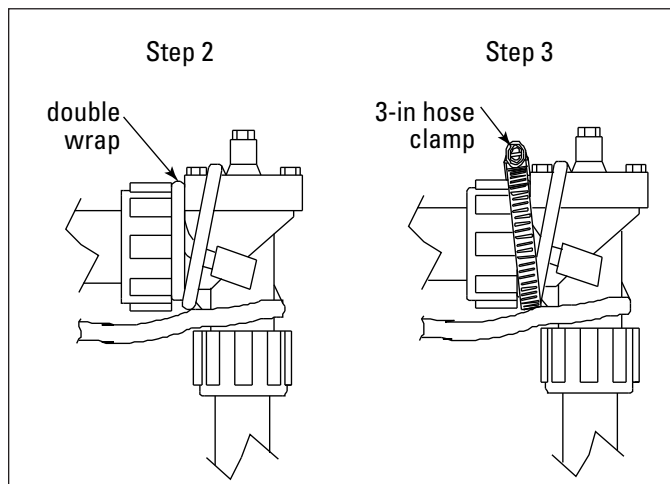

Cold Climate Kit, Detail A

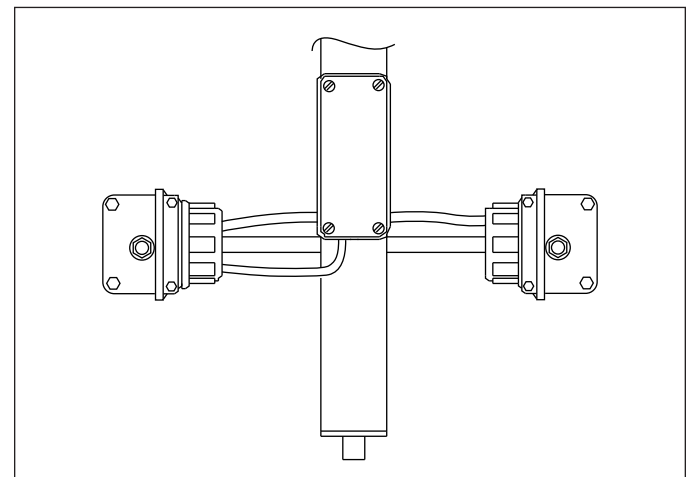

Cold Climate Kit, Detail C

Explosion Vents

WARNING

Personal injury, death, or property damage can result from material discharge during venting.

The material discharged during the venting of an explosion must be safely directed outdoors away from areas occupied by personnel to reduce risk of personal injury or property damage.

The risk of injury or damage can be minimized or avoided by locating vented equipment outside buildings and away from normally occupied areas.

Explosion vents should be inspected regularly to confirm physical and operational condition. Replace any damaged parts immediately.

Standard explosion vents are intended for outdoor installations only.

NOTICE

Remove all shipping materials, including covers, from the explosion relief vents prior to installation. Failure to remove shipping covers will seriously compromise explosion vent operation.

Explosion venting calculations are based on formulas from NFPA-68 for outdoor applications only, with no duct or obstructions on the explosion vent panel.

Contact Donaldson Torit for assistance in calculating specific venting requirements for equipment.

Troubleshooting

Problem	Probable Cause	Remedy
Power pack fan and motor do not start	Improper motor wire size	Rewire using the correct wire gauge as specified by national and local codes.
	Not wired correctly	Check and correct motor wiring for supply voltage. See motor manufacturer's wiring diagram. Follow wiring diagram and the National Electric Code.
	Unit not wired for available voltage	Correct wiring for proper supply voltage.
	Input circuit down	Check power supply to motor circuit on all leads.
	Electrical supply circuit down	Check power supply circuit for proper voltage. Check for fuse or circuit breaker fault. Replace as necessary.
Power pack fan and motor start, but do not stay running	Incorrect motor starter installed	Check for proper motor starter and replace if necessary.
	Access doors are open or not closed tight	Close and tighten access doors. See Filter Replacement.
	Hopper discharge open	Check that dust container is installed and properly sealed.
	Damper control not adjusted properly	Check airflow in duct. Adjust damper control until proper airflow is achieved and the blower motor's amp draw is within the manufacturer's rated amps.
	Electrical circuit overload	Check that the power supply circuit has sufficient power to run all equipment.
Clean-air outlet discharging dust	Filters not installed correctly	See Filter Installation.
	Filter damage, dents in the end caps, gasket damage, or holes in media	Replace filters as necessary. Use only genuine Donaldson replacement parts. See Filter Installation.
	Access cover(s) loose	Tighten access doors securely. See Filter Installation.
Insufficient airflow	Fan rotation backwards	Proper fan rotation is clockwise from the top of the unit. The fan can be viewed through the back of the motor. See Preliminary Start-Up Check.
	Access doors open or not closed tight	Check that all access doors are in place and secured. Check that the hopper discharge opening is sealed and that dust container is installed correctly.
	Fan exhaust area restricted	Check fan exhaust area for obstructions. Remove material or debris. Adjust damper flow control.
	Filters need replacement	Remove and replace using genuine Donaldson replacement filters. See Filter Removal and Installation.

Troubleshooting

Problem	Probable Cause	Remedy
Insufficient airflow continued	Lack of compressed air	See Rating and Specification Information for compressed air supply requirements.
	Pulse cleaning not energized	Use a voltmeter to check the solenoid valves in the control panel. Check pneumatic lines for kinks or obstructions.
	Dust storage area overfilled or plugged	Clean out dust storage area. See Dust Disposal.
	Pulse valves leaking compressed air	Lock out all electrical power to the unit and bleed the compressed air supply. Check for debris, valve wear, pneumatic tubing fault, or diaphragm failure by removing the diaphragm cover on the pulse valves. Check for solenoid leaks or damage. If pulse valves or solenoid valves and tubing are damaged, replace.
	Solid-State timer failure	Using a voltmeter, check supply voltage to the timer board. Check and replace the fuse on the timer board if necessary. If the fuse is good and input power is present but output voltage to the solenoid is not, replace the timer board. See Solid-State Timer Installation.
	Solid-State timer out of adjustment	See Solid-State Timer and Solid-State Timer Wiring Diagram.
No display on the Delta P Controller	No power to the controller	Use a voltmeter to check for supply voltage.
	Fuse blown	Check the fuse in the control panel. See wiring diagram inside the control panel. Replace if necessary.
Display on Delta P Controller does not read zero when at rest	Out of calibration	Recalibrate as described in Delta P Maintenance Manual.
	With collector discharging outside, differential pressure is present from indoor to outdoor	Recalibrate with the pressure tubing attached as described in the Delta P Maintenance Manual.
Delta P Controller ON, but cleaning system does not start	Pressure tubing disconnected, ruptured, or plugged	Check tubing for kinks, breaks, contamination, or loose connections.
	Not wired to the timing board correctly	Connect the pressure switch on the timer board to Terminals 7 and 8 on TB3.
	Faulty relay	Using a multimeter, test relay for proper closure. Replace if necessary.

Problem	Probable Cause	Remedy
Pulse cleaning never stops	Pressure switch not wired to the timer board correctly	Connect the pressure switch on the timer board to Terminals 7 and 8 on TB3.
	Pressure switch terminals on the timer board jumpered	Remove jumper wire on Solid-State Timer board before wiring to the Delta P Control.
	High Pressure On or Low Pressure Off setpoint not adjusted for system conditions	Adjust setpoints to current conditions.
	Pressure tubing disconnected, ruptured, plugged, or kinked	Check tubing for kinks, breaks, contamination, or loose connections.
Alarm light is ON	Alarm setpoint too low	Adjust to a higher value.
	Excess pressure drop	Check cleaning system and compressed air supply. Replace filters if filters do not clean down.
	Pressure tubing disconnected, ruptured, plugged, or kinked	Check tubing for kinks, breaks, contamination, or loose connections.
Delta P arrow keys to not work	Improper operation	Press and hold one of the three setpoint keys to use arrow keys.
	Programming keys disabled	Remove the Program Disable jumper from Terminals 3 and 4 on TB2.
Cleaning light is ON, but cleaning system not functioning	Improper wiring	Check wiring between the Delta P Control and the timer board, and between the timer board and solenoid valve coils.
	Defective solenoids	Check all solenoid coils for proper operation.
	Timer board not powered	Check power ON light on timer board's LED display. If not illuminated, check the supply voltage to the timer board. Check the fuse on the timer board. Replace if necessary.
	Timer board defective	If LED is illuminated, observe the output display. Install a temporary jumper across the pressure switch terminals. Output levels should flash in sequence. Check output using a multimeter set to 150-Volt AC range. Measure from SOL COM to a solenoid output. The needle will deflect when LED flashes for that output if voltage is present. If LED's do not flash, or if no voltage is present at output terminals during flash, replace the board.

The Donaldson Torit Warranty

Donaldson does not warrant against damages due to corrosion, abrasion, normal wear and tear, product modification, or product misapplication. Donaldson also makes no warranty whatsoever as to any goods manufactured or supplied by others including electric motors, fans and control components. After Donaldson has been given adequate opportunity to remedy any defects in material or workmanship, Donaldson retains the sole option to accept return of the goods, with freight paid by the purchaser, and to refund the purchase price for the goods after confirming the goods are returned undamaged and in usable condition. Such a refund will be in the full extent of Donaldson's liability. Donaldson shall not be liable for any other costs, expenses or damages whether direct, indirect, special, incidental, consequential or otherwise. The terms of this warranty may be modified only by a special warranty document signed by a Director, General Manager or Vice President of Donaldson. Failure to use genuine Donaldson replacement parts may void this warranty. THERE EXIST NO OTHER REPRESENTATIONS, WARRANTIES OR GUARANTEES EXCEPT AS STATED IN THIS PARAGRAPH AND ALL OTHER WARRANTIES INCLUDING MERCHANTABILITY AND FITNESS FOR A PARTICULAR PURPOSE, WHETHER EXPRESS OR IMPLIED ARE HEREBY EXPRESSLY EXCLUDED AND DISCLAIMED.



Donaldson
FILTRATION SOLUTIONS

Parts and Service

For genuine Donaldson replacement filters and parts, call the Parts Express Line. For faster service, have unit's model and serial number, quantity, part number, and description available.

Donaldson Australasia
Tel: 1800 503 878 (AU)
Tel: 0800 743 387 (NZ)
Website: www.donaldsonfilters.com.au

Donaldson China
Tel: 400 820 1038
Website: www.donaldson.cn

Donaldson South Asia
Tel: +91 124 480 7536
Website: www.india.donaldson.com

Donaldson Japan
Tel: +81 42 540 4114
Website: www.donaldson.co.jp

Donaldson Korea
Tel: +82 251 733 33
Website: www.donaldson.co.kr

Donaldson Europe
Tel: +32 16 383 811
Website: www.donaldson.com

Donaldson Southeast Asia
Tel: +65 6349 8168
Website: www.asia.donaldson.com

Donaldson USA
Tel: +1 800 365 1331
Website: www.donaldson.com

Donaldson Company, Inc. is the leading designer and manufacturer of dust, mist, and fume collection equipment used to control industrial-air pollutants. Our equipment is designed to help reduce occupational hazards, lengthen machine life, reduce in-plant maintenance requirements, and improve product quality.