

Vibra-Shake™

VS-550, VS-1200, VS-1500, VS-2400 and VS-3000

Installation and Operation Manual

Installation, Operation, and Service Information

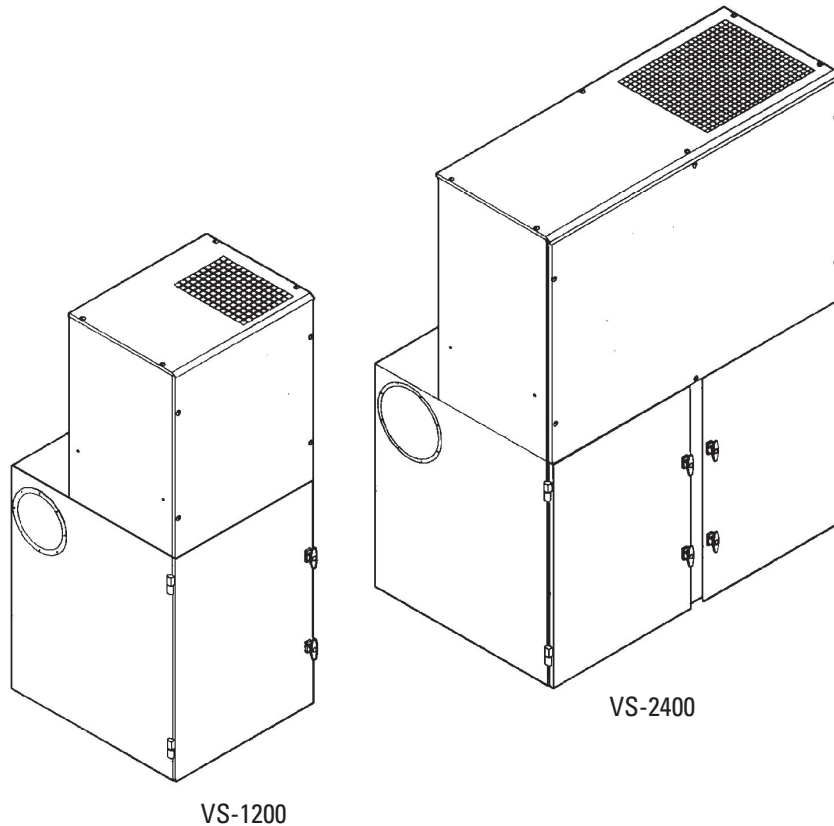

This manual contains specific precautions related to worker safety. The hazard alert image denotes safety related instructions and warnings in this manual. DO NOT install, operate, or perform maintenance on this collector until you have read and understood the instructions, precautions and warnings contained within this manual.

IMPORTANT NOTES

This manual has been supplied to assist with the installation, operation and maintenance for the collector purchased. Please read the manual before installing, operating, or performing maintenance on the collector as it contains specific precautions for worker safety. It is the owner's responsibility to ensure that this manual is available for use by installers, operators and maintenance personnel that will be working with this collector. This manual is the property of the owner and should be left with the collector when installation has been completed. **DO NOT** operate this collector until you have read and understood the instructions and warnings located in this manual.

For additional copies of this manual, contact Donaldson Torit.



The Safety Alert Symbol indicates a hazardous situation which, if not avoided could result in death or serious injury. Obey all safety messages following this symbol to avoid possible injury or death. The possible hazards are explained in the associated text messages.

NOTICE

NOTICE indicates a potential situation or practice which is not expected to result in personal injury, but which if not avoided, may result in damage to equipment.

Contents

1	Safety Communication	1
2	Product Description	3
	Collector Design	3
	Standard Equipment	3
3	Operation	4
4	Product Service	5
	Dust Disposal	5
	Filter Replacement	6
	Troubleshooting	7
	Appendix A - Installation	10
	Installation	11
	Lifting Information	12
	Hopper and Leg Installation	12
	Cabinet Assembly	14
	Electrical Wiring	15
	Options and Accessories	17
	Hopper Discharge Accessories	17
	5-Gallon Pail Pack	17
	55-Gallon Drum Pack	18
	Control Box with Solid State Timer	19
	Control Box with PLC	20
	Clean Cycle Selection Instructions	20
	PLC Selection Instructions	21
	Stop Mode Recovery Instructions	22
	Shaker Assembly	24
	Pressure Switch Connection	24
	Start-up / Commissioning	25
	Decommissioning Alternate	26
	Product Information	27
	Service Notes	27
	Donaldson Industrial Air Filtration Warranty	28

1 Safety Communication



Improper operation of dust collectors and/or dust control systems may contribute to conditions in a work area or facility which could result in severe personal injury, and product or property damage. All dust collection equipment should be used only for its intended purpose and should be properly selected and sized for its intended use.

Process owners have important responsibilities relating to identifying and addressing potential hazards in their processes. When the potential for handling combustible dust exists within a process the process owner should include combustion hazards in their risk management activities and should comply with applicable codes and standards related to combustible dust.

Electrical installation must be performed by a qualified electrician.

This equipment is not designed to support site ducts, piping, or electrical services. All ducts, piping, or electrical services must be adequately supported to prevent injury and/or property damage.

Site selection must account for wind, seismic zone, and other load conditions.

Equipment may reach peak sound pressure levels above 80 dB (A). Noise levels should be considered when selecting collector location.

Most dusts present safety and health hazards that require precautions. Wear eye, respiratory, head and other protection equipment suitable for the type of dust.

Some components may be heavier than they appear. Use appropriate lifting methods to avoid personal injury and/or property damage.

Combustible Dust Hazards

Among other considerations, the current NFPA standards require owners whose processes involve potentially combustible materials to have a current Dust Hazard Analysis, which can serve as the foundation for their process hazard mitigation strategy. Mitigation may include but is not limited to:

- Prevention of all ignition sources from entering any dust collection equipment.
- Selection and implementation of fire and explosion mitigation, suppression, and isolation strategies appropriate for the risks in their process.
- Development and use of work practices to maintain safe operating conditions, and to ensure combustible dust does not accumulate within their plant or process equipment.

Donaldson designs, manufactures, and sells industrial air filtration products for a wide variety of applications. Some applications may include processes or materials with inherent fire and explosion hazards. Donaldson is neither an expert nor a certified consultant in fire, spark, or explosion detection, suppression, or control. Donaldson does not provide engineering consulting services related to process or dust hazard analyses, or code and standard compliance. Complying with applicable codes and standards and managing the risks associated with the process or materials remains the responsibility of the process owner/operator. Donaldson may provide referrals to consultants, suppliers of equipment or services related to the detection and/or mitigation of sparks, fires and/or explosions, but Donaldson does not assume responsibility for any such referrals, nor does Donaldson assume any liability for the fitness of a mitigation strategy or product for a particular installation or application. The process owner's final selection of dust collectors and risk mitigation strategies should be based on the outcome of a Dust Hazard / Process Hazard Analysis performed by the process owner. Although early engagement of a dust collector supplier provides helpful insights on the availability and features of various products, process owners should consult with a combustible dust expert and/or a process safety expert before making actual product and mitigation strategy selections.

Donaldson recommends that all industrial air filtration system designs be reviewed and approved by an expert consultant who is responsible for the integrity of the system design and compliance with applicable codes and standards. It is the process owner's responsibility to understand the risks in their process and mitigate those risks in accordance with all applicable laws, regulations and standards, including those published by the NFPA. Donaldson also recommends that proper maintenance and housekeeping procedures and work practices be evaluated, developed, and followed to maintain any industrial air filtration products in safe operating condition.

Many factors beyond the control of Donaldson can affect the use and performance of Donaldson products in a particular application, including the conditions under which the product is used. Since these factors are uniquely within the user's knowledge and control, it is essential the user evaluate the Donaldson products to determine whether the product is fit for the particular purpose and suitable for the user's application. All products, product specifications, and data (airflow, capacity, dimensions, or availability) are subject to change without notice, and may vary by region or country.

2 Product Description

The Vibra Shake, Model VS Collectors are high-efficiency, intermittent-duty dust collectors with cartridge-style filters for airflow ranging from 550 to 3,000 cfm. The patented, self-contained collector uses a high frequency, vibration filter cleaning system. A cellulose-based filter cartridge with a nylon mesh pre-filter provides optimum efficiency and ease of maintenance. The nylon mesh pre-filter accumulates a dust cake, and the cartridge acts as a cleanable secondary filter. The Vibra Shake dust collectors standard features include an acoustic-lined blower chamber and automatic filter cleaning.

Designed to increase the versatility of the collector, standard options include a variety of discharge arrangements, dust drawer or hopper-style cabinets, and 5- or 55-gallon dust disposal options.

The two-stage filter design makes the VS collector especially effective on fibrous particulate or bimodal dust, which is a mixture of large and small particulate. The VS is for use on negative pressure systems only.

VS collectors are not recommended for applications with very fine, mono-sized nonagglomerative particulate such as welding fume. The filter cartridge will effectively filter the dust, but the high air-to-media ratios will not release the fine particulate from the filter during cleaning.

Typical VS applications include metal working, pharmaceutical, composite and precious metals industries.

Rating and Specification Information

General rating and specification information can be found in the product literature provided with the collector and is available on the Donaldson website. For specific load values for a collector, see the Specification Control Drawing shipped with the collector.

Collector Design

Standard Equipment

Standard dust drawer collectors consist of a self-contained collector housing the filters, blower, clean and dirty-air chambers and dust drawers.

3 Operation

Dust enters through the cabinet inlet and passes through a fine mesh pre-filter on the outside of the filter. The pre-filter is spaced 1-in from the filter cartridge and is designed to catch fibrous dust while fine particulate passes through to collect on the outside surfaces of the filter cartridge. Clean, filtered air flows up through the center of the filter cartridge to the blower, through the silencer, and exits through the top clean-air outlet.

Model VS is an intermittent-duty collector, which means that cleaning starts when the fan is turned OFF and the appropriate fan run-down time is complete. The solid-state timer automatically starts the cleaning sequence 60-seconds after the fan is turned OFF for the VS-550, VS-1200, and VS-1500 and 180-seconds for Models VS-2400 and VS-3000. This is the fan run-down time. Power to controls must remain ON to operate cleaning mechanism.

The vibration motor starts and filter cleaning begins for a preset time of 30-, 60- or 90-seconds. A diaphragm at the bottom of the filter cartridge opens when the fan is turned OFF which allows fine dust particles to fall into the dust drawer or optional hopper for disposal.

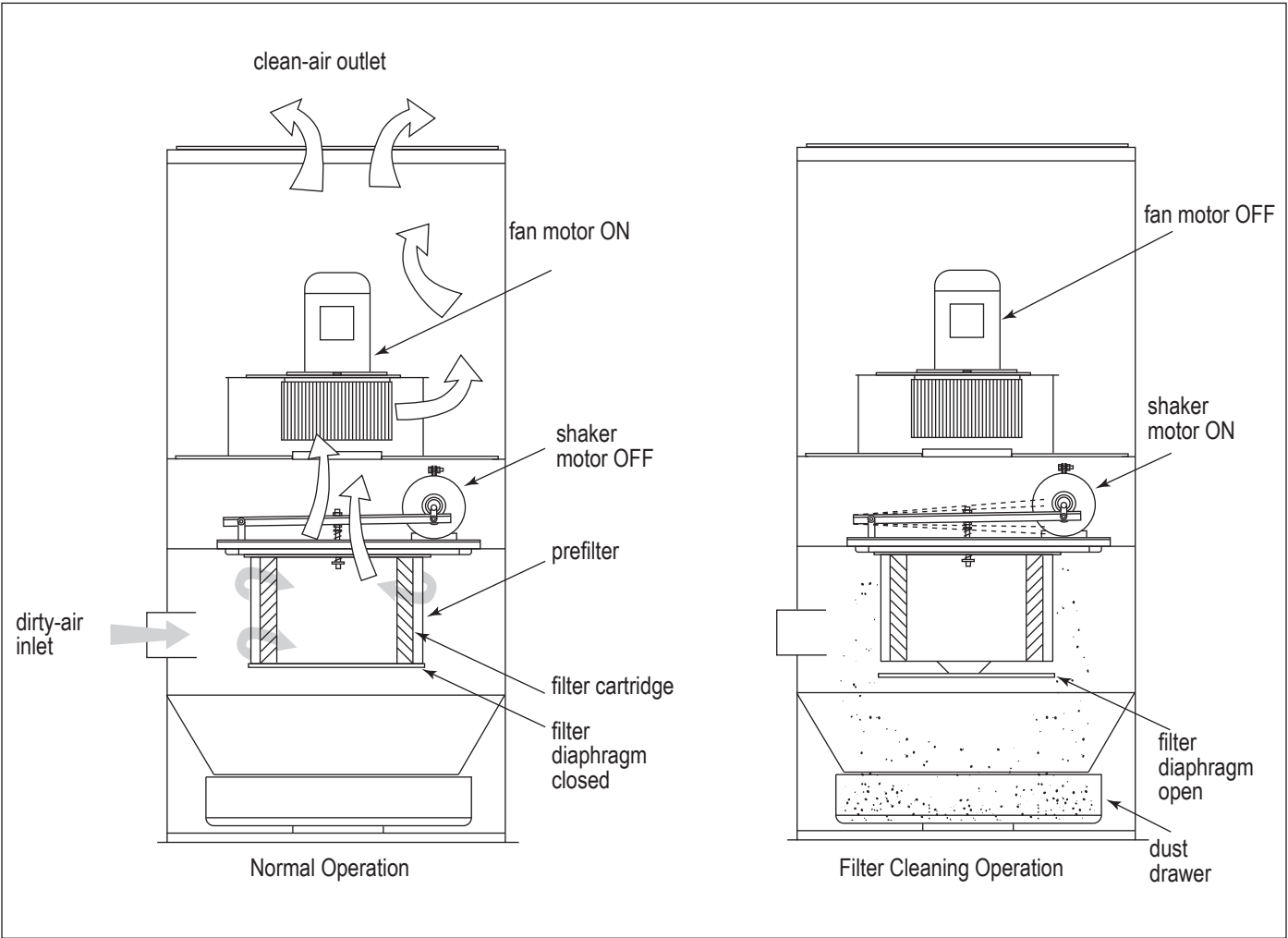

Collector Operation

4 Product Service



During service activities there is some potential for exposure to the dust in the collector. Most dusts present safety and health hazards that require precautions. Wear eye, respiratory, head and other protection equipment suitable for the type of dust when performing any service activities.

Use appropriate access equipment and procedures.

LOCK-OUT all energy sources prior to performing any service or maintenance on the equipment.

Electrical service or maintenance work must be performed by a qualified electrician and comply with all applicable national and local codes.

Operational Checklist

1. Monitor the physical condition of the collector and repair or replace any damaged components.

Routine inspections will minimize downtime and maintain optimum system performance. This is particularly important on continuous-duty applications.

2. Monitor pressure drop across filters.

Abnormal changes in pressure drop may indicate a change in operating conditions and possibly a fault to be corrected.

3. Monitor exhaust.

4. Monitor dust disposal. Empty the dust drawers at the end of each shift, or more frequently if necessary. Dust drawers should be emptied when they are more than 2/3 full.

Dust Disposal

1. Shut the collector OFF prior to emptying the dust container (bin, pail, or drum).
2. Transfer dust from the dust container to a suitable disposal site and dispose of dust in accordance with local requirements for the materials being collected.
3. Empty when dust container is 2/3 full. Check integrity of gasket under container cover. Replace gasket if worn or damaged.
4. If optional slide gate is used, close gate before servicing the container.



Sharp edge of slide gate may result in personal injury while closing the slide gate. Keep hands clear when operating the slide gate.

5. Replace or reinstall dust container, reclamp to the collector and open slide gate (if applicable).

NOTICE

To avoid possible damage to the fan motor, maintain a seal below the collector if servicing the dust storage device while the fan is running.

6. The collector can now be returned to service.

Filter Replacement



Most dusts present safety and health hazards that require precautions. Wear eye, respiratory, head and other protection equipment suitable for the type of dust.

Use proper safety and protective equipment when removing contaminants and filters.

Dirty filters may be heavier than they appear. Use appropriate lifting methods to avoid personal injury and/ or property damage.

Turn all power OFF and lock out all power before performing service or maintenance work.

Do not operate with missing or damaged filters.

Prefilter

1. Turn all power to collector OFF.
2. Remove the nylon mesh prefilter.
3. Reinstall the prefilter placing the top edge against the upper end cap of the filter cartridge. Stretch the screen for a tight fit and secure using a hook-and-loop fastener.

Note: The prefilter must cover all holes in the perforated liner. Stretch to fit.

Filter Cartridge

1. Turn all power to collector OFF.
2. Open the bottom access door.
3. Loosen four filter support knobs.
4. Turn the retaining ring counterclockwise to release the ring and filter.
5. Remove the retaining ring and filter and dispose of filter in accordance with local requirements for the materials being collected.
6. Check integrity of gasket on the shaker panel. Replace gasket if worn or damaged.
7. Install new filter reusing the retaining ring and tighten the four filter support knobs by hand.
8. Check integrity of door gasket. Replace gasket if worn or damaged.
9. Close bottom access door and secure latches.

Note: Slight bleed-through on new filters is normal and will disappear as the filter seasons.

12. The collector can now be returned to service.

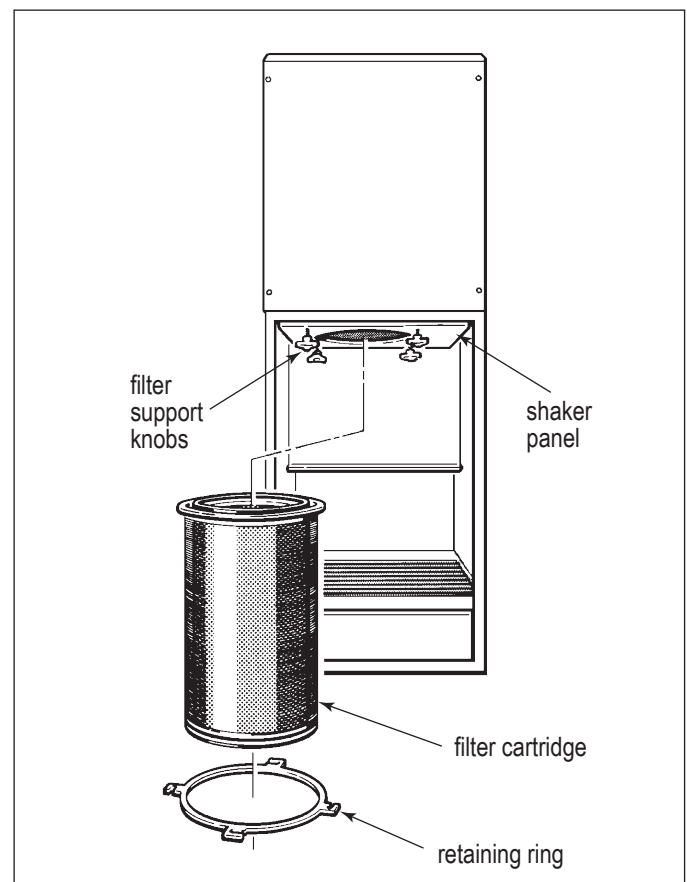

Filter Replacement

Troubleshooting

Problem	Probable Cause	Remedy
Fan blower and motor do not start	Improper motor wire size	Rewire using the correct wire gauge as specified by national and local codes.
	Not wired correctly	Check and correct motor wiring for supply voltage. See motor manufacturer's wiring diagram. Follow wiring diagram and the National Electric Code.
	Collector not wired for available voltage	Correct wiring for proper supply voltage.
	Input circuit down	Check power supply to motor circuit on all leads.
	Electrical supply circuit down	Check power supply circuit for proper voltage. Check for fuse or circuit breaker fault. Replace as necessary.
	Damaged motor	Replace damaged motor.
Fan blower and motor start, but do not stay running	Incorrect motor starter installed	Check for proper motor starter and replace if necessary.
	Access doors are open or not closed tight	Close and tighten access doors. See Filter Installation.
	Hopper discharge open	Check that dust container is installed and properly sealed.
	Damper control not adjusted properly	Check airflow in duct. Adjust damper control until proper airflow is achieved and the blower motor's amp draw is within the manufacturer's rated amps.
	Electrical circuit overload	Check that the power supply circuit has sufficient power to run all equipment.
	Inlet too large	Contact Donaldson Torit for assistance.
Clean-air outlet discharging dust	Filters not installed correctly	See Filter Installation.
	Filter damage, dents in the end caps, gasket damage, or holes in media	Replace filters as necessary. Use only genuine Donaldson replacement parts. See Filter Installation.

Problem	Probable Cause	Remedy
Insufficient airflow	Fan rotation backwards	Proper fan rotation is clockwise when viewed from the motor side or counterclockwise when viewed through the inlet cone. See Preliminary Start-Up Check.
	Access doors open or not closed tight	Check that all access doors are in place and secured. Check that the hopper discharge opening is sealed and that dust container is installed correctly.
	Fan exhaust area restricted	Check fan exhaust area for obstructions. Remove material or debris. Adjust damper flow control.
	Filters need replacement	Remove and replace using genuine Donaldson replacement filters. See Filter Removal and Installation.
	Collapsed or obstructed ductwork	Remove and clean duct. Replace collapsed duct.
	Improper duct size or too much flexible duct	Contact Donaldson Torit for assistance.
	Collapsed or obstructed ductwork	Remove and clean duct. Replace collapsed duct.
	Improper duct size or too much flexible duct	Contact Donaldson Torit for assistance.
	Dust storage area overfilled or plugged	Clean out dust storage area. See Dust Disposal.
	Nylon mesh prefilter plugged or not in place	Remove the nylon mesh filter. See Filter Removal and Installation.
	Shaker ring not gapped correctly	Check and reset the shaker ring gap. See Shaker Assembly illustration.
	Shaker arm restricted	Disconnect the shaker bar and check the nylon link and bearing - it should pivot in the shaker channel easily. With the shaker bar disconnected, allow the shaker motor to run and check the amp draw. If over 2.5 amps, replace the shaker motor.

Troubleshooting

Problem	Probable Cause	Remedy
Control board indicator light not flashing	No input voltage to transformer	Check and correct voltage at the transformer's primary and secondary terminal. See Electrical Connection.
	No output voltage from transformer	Replace transformer fuse with identical fuse only. Other types may cause shaker motor damage.
	Faulty transformer	Check for 115 to 120-Volts at the transformer's secondary terminals. Replace transformer if no output voltage is present.
Control board indicator light flashing, but shaker motor does not start	Transformer not wired correctly.	Correct transformer wiring.
	Shaker motor not wired correctly	See Electrical Connection.
	Faulty shaker motor	Replace shaker motor.
	Pressure switch tubing not installed correctly	Check tubing connection and condition. Do not kink or pinch tubing. Note: The main blower fan must be ON for a minimum of 30-seconds for the timing sequence to start.
	Check pressure switch adjustment (if adjustable)	Turn screw clockwise until it stops and back out approximately three turns counterclockwise.
	Faulty pressure switch	With power to the solid state timer ON, remove the two wires from the pressure switch. Using a small wire, jumper across the end of the two white wires and maintain contact for at least 30-seconds. Remove the jumper wire and wait 60-seconds for VS-550, 1200, and 1500 or 180-seconds for VS-2400 and 3000. If the shaker motor starts, replace the pressure switch.
Control board flashing light stops	Primary or secondary transformer fuse blown	Replace transformer fuse with identical fuse only. Other types may cause shaker motor damage.
	Solid State Timer fuse blown	Replace with Littlefuse™ 3-amp, 3AG 125 VAC MDX Slow Blo only.
	Shaker mechanism malfunctioning	Disconnect the black and white wires from the shaker motor M1/J3 circuit on the control board. Connect the shaker motor to 115-Volt power from a separate source and check amp draw. If over 2.5 amps, replace the shaker motor. See Electrical Connection, Control Box and Shaker Assembly.

Appendix A - Installation

Installation



Electrical Installation (including bonding and grounding of the collector) must be performed by a qualified electrician.

This equipment is not designed to support site ducts, piping, or electrical services. All ducts, piping, or electrical services must be adequately supported to prevent injury and/or property damage.

Do not install in classified hazardous atmospheres without an enclosure rated for the application.

Service must be performed by trained and qualified maintenance personnel.

Turn all power off and lock out all power before performing service or maintenance work. It is not unusual for the equipment to be operated from a remote location, so equipment may start or stop unexpectedly.

Equipment may reach peak sound pressure levels above 80 dB (A). Noise levels should be considered when selecting equipment location.

Location and Site Selection



Codes may regulate recirculating filtered air in your facility. Consult with the appropriate authorities having jurisdiction to ensure compliance with all national and local codes regarding recirculating filtered air.

Equipment location must conform to all codes and standards, should be suitable for the type of dust being handled and should ensure easy access for service and utility connections. Site selection must account for wind, seismic zone and other load conditions.

The equipment must be anchored once in final position. Anchors must comply with local code requirements. Anchors, foundation or support framing must be capable of supporting dead, live, wind, seismic, and other applicable loads. Consult a qualified engineer for final selection of foundation or support framing.

Note: Ensure the inlet has at least five diameters of straight duct prior to the collector inlet including a transition to the full inlet dimensions. Inlet transition should have a taper with a maximum of a 90-degree included angle.

Follow industry practice relative to clean air velocity into a fan.

Provisional Anchor Bolt Recommendations

The quantity of anchor bolts should match the number of holes provided in the base plates of the collector. Anchor diameter is typically 1/8-inch less than the baseplate hole diameter. Anchors should project a minimum of 1 3/4 -inch and account for nut, washer, baseplate, and shims/grout.

Delivery and Inspection

Upon arrival inspect equipment and report any damage to delivery carrier. File any damage claims with the delivery carrier. Request a written inspection report from the Claims Inspector to substantiate all damage claims.

Compare the equipment received with the description of product ordered. Report any incomplete shipments to the delivery carrier and your Donaldson Torit representative.

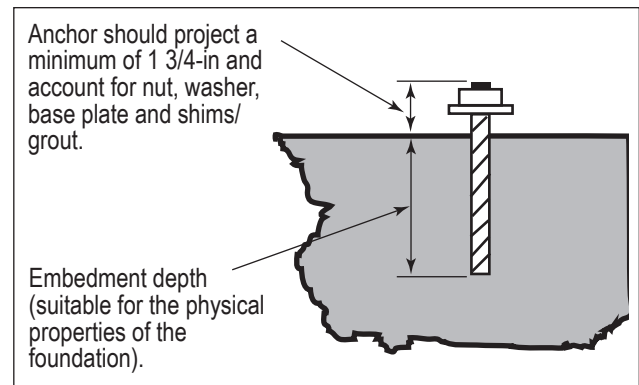

Typical Foundation Anchor

Unloading and Positioning



Equipment should be lifted only by qualified crane or fork truck operators.

Failure to lift the equipment correctly can result in severe personal injury and/or property damage.

1. Remove any crates or shipping straps.
2. Lift the packaged collector from transport container.
3. Inspect for any damage and/or missing parts and report to freight carrier.
4. Check for any hardware which may have become loose during shipment and tighten as necessary.

Lifting Information



Failure to lift the equipment or sub-assemblies correctly can result in severe personal injury and/or property damage.

Only qualified crane or forklift operators should be allowed to lift equipment.

1. Use all lifting points provided.
2. Use clevis connectors, not hooks, on lifting slings.
3. Use spreader bars to prevent damage to equipment.
4. Check the Specification Control drawing for weight and dimensions of the collector and components to ensure adequate crane capacity.
5. Lift collector and accessories separately and assemble after collector is in place.
6. Use drift pins to align holes in section flanges during assembly.

Hopper and Leg Installation



Anchors must comply with local code requirements and be capable of supporting dead, live, wind, seismic and other applicable loads.

Anchor sizes shown are provisional, as final anchor sizing will depend on jobsite load conditions, equipment location, foundation/framing design variables and local codes.

Consult a qualified engineer for final selection of suitable anchors.

Temporary support is required until all legs and cross-bracing are in place.

Reference Typical Foundation Anchor and leg assembly drawing shipped with the collector prior to starting assembly.

1. Prepare the foundation or support framing in the selected location. Locate and install anchors.

2. Lift the hopper using a crane.
3. Stand each leg on its pad in position under hopper.
4. Use drift pins to align holes in the hopper with the holes in the legs.
5. Secure legs to hopper using bolts, washers, and nuts provided. Do not tighten hardware at this time. Do not remove crane.
6. Position and bolt the cross brace in place using the hardware provided. Do not tighten hardware.
7. Bolt inside and outside cross braces together where they form a X. Do not tighten hardware.
8. Lift the hopper and leg assembly and lower slowly to the anchor bolts.
9. Level the hopper at the top flange using steel shims if necessary. Secure leg pads to anchor bolts with the appropriate customer-supplied washers and nuts.
10. Tighten all hardware on the legs, cross braces, and anchor bolts. Recheck level and adjust as necessary.
11. Remove crane.

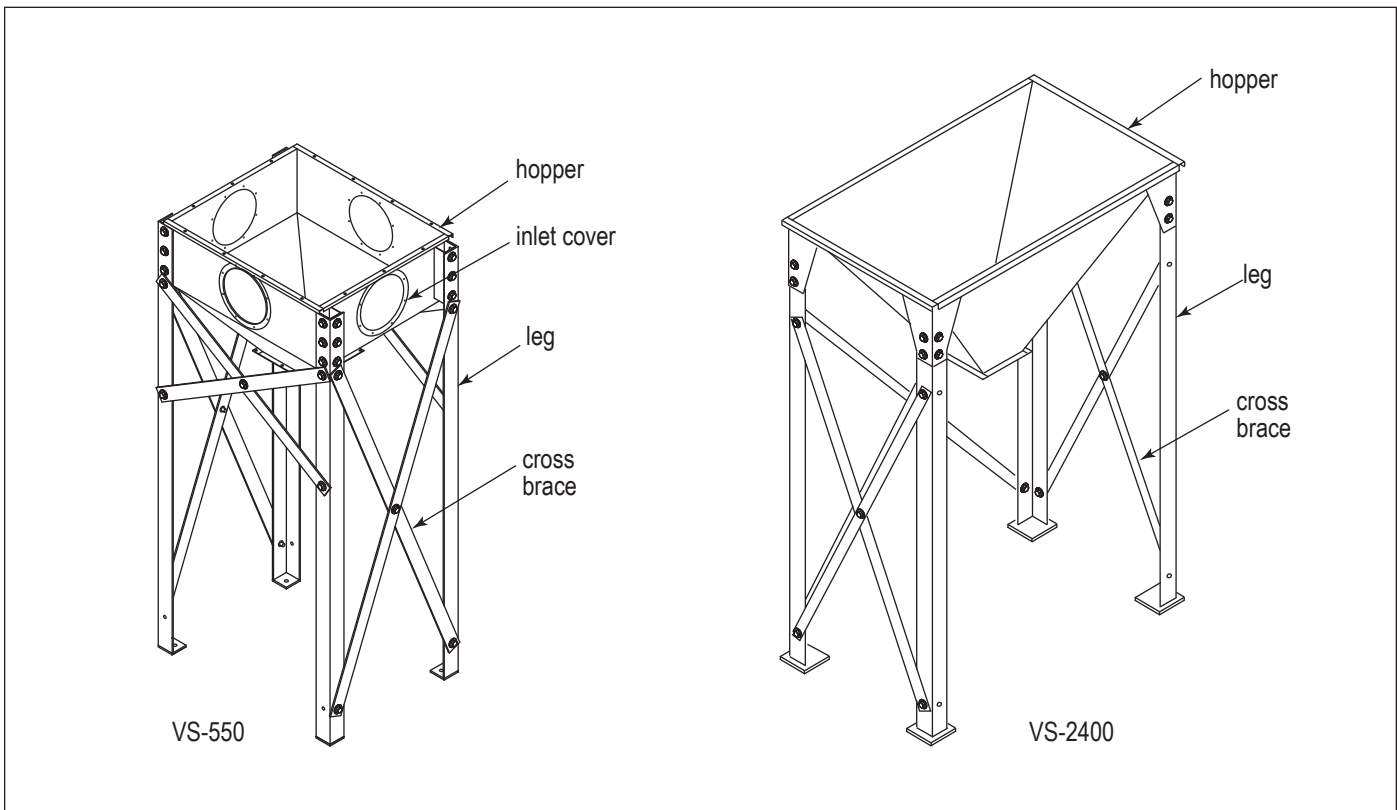

Hopper and Leg Installation

Cabinet Assembly

1. Place 1/4-in diameter, rope-type sealant around the hopper's top flange toward the outside of the bolt pattern.
2. Lift the cabinet into position over the leg and hopper assembly and lower slowly.

Note: Access the lifting lugs on VS-2400 and VS-3000 by removing the top cover panel. Lifting lugs are located on the blower support panel.

3. Align the holes in the hopper flange with the holes in the cabinet and secure using the hardware supplied.

Note: Inlet collars can be located on any side of the VS-500, -1200, or -1500 hopper by removing the cover plate.

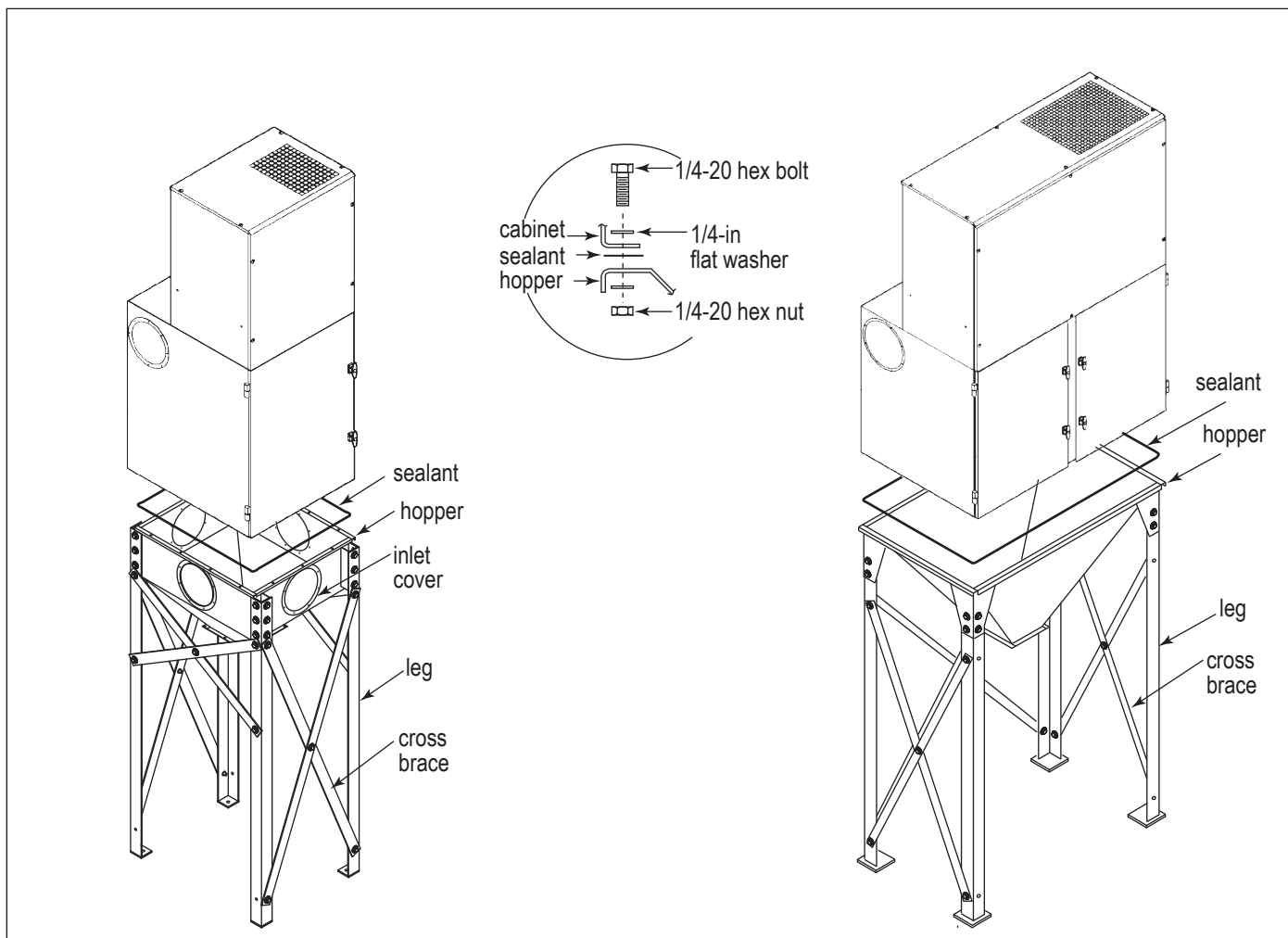

Cabinet Assembly

Electrical Wiring



Electrical installation, service, or maintenance work must be performed by a qualified electrician and comply with all applicable national and local codes.

Turn all power off and lock out all power before performing service or maintenance work. It is not unusual for the equipment to be operated from a remote location so equipment may start or stop unexpectedly.

The appropriate wiring schematic and electrical rating must be used. See collector's rating plate for required voltage.

Do not install in classified hazardous atmospheres without an enclosure rated for the application.

1. Using the wiring diagram supplied, wire the customer-supplied disconnect switch and fan starter. Make the connections to the fan motor, and control box. Use appropriate wire gauge for rated amp load as specified by local codes.
2. Turn the fan motor ON then OFF to check for proper rotation by referencing the rotation arrow located on the motor's mounting plate.

To reverse rotation, three-phase power supply:
Switch any two leads on the motor junction box.



Do not look into fan outlet to determine rotation. View the fan rotation through the back of the motor.

Check that the exhaust plenum is free of tools or debris before checking blower/fan rotation.

Stand clear of exhaust to avoid personal injury.

Do not interchange a power lead with the ground wire. Severe personal injury and/or property damage may result.

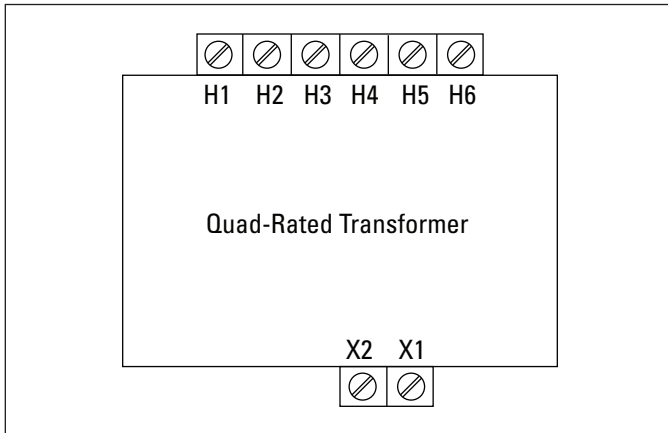

Quad-Rated Transformer

Input Voltage				
H1-H2	H1-H3	H1-H4	H1-H5	H1-H6
200	220	380	440	550
208	230	400	460	575
	240	415	480	600
Output Voltage				
120-Volt Nominal				

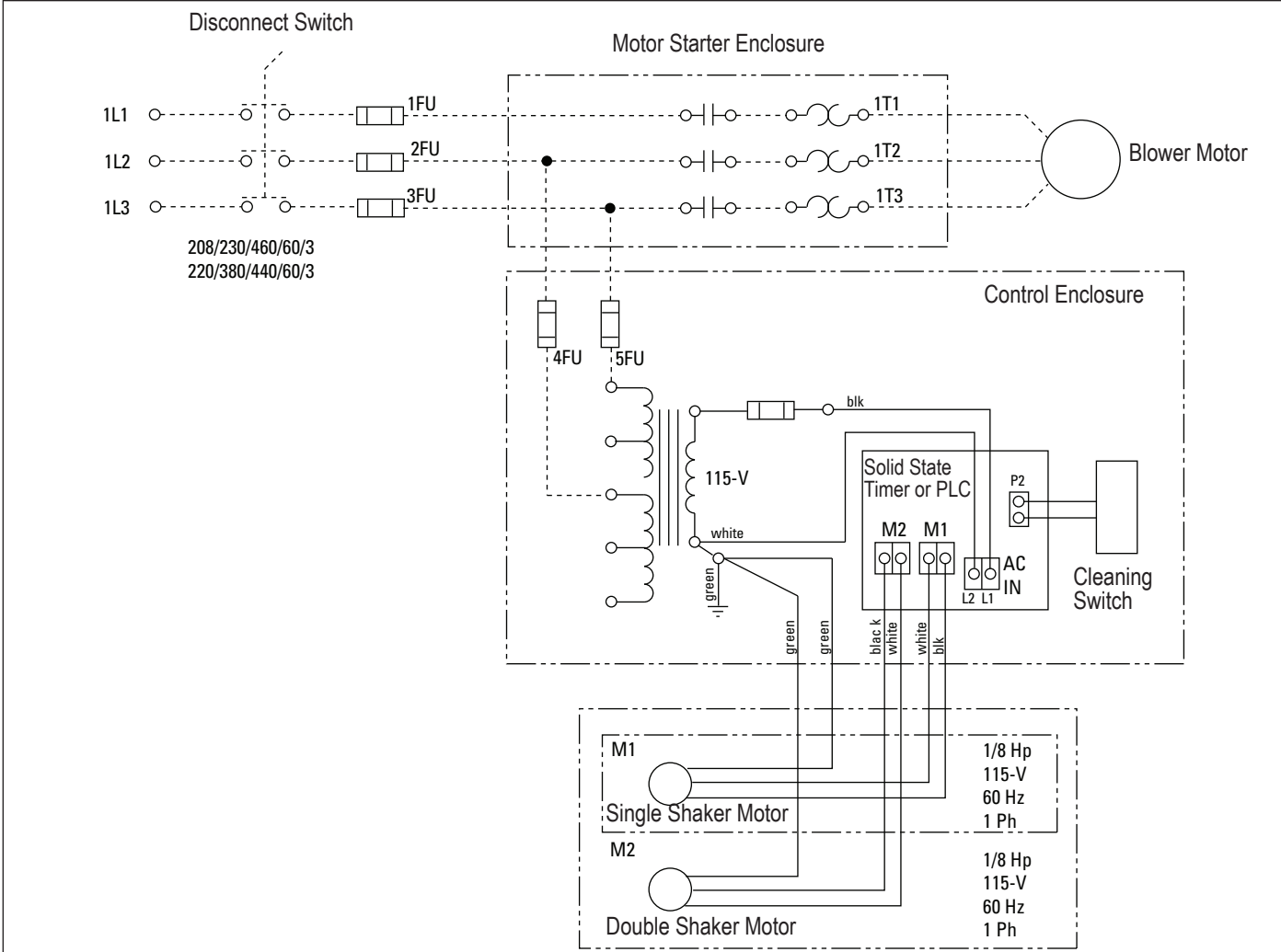

Cleaning Operation

1. Collector shutdown.
2. Rundown time: 60-second, single shaker motor, 180-second, double shaker motor.
3. 60-second cleaning cycle.
4. No time delay on start-up. If start-up is initiated during the cleaning operation, the shaker motor will turn OFF.

Timer Connection

- M1 White and black motor leads factory wired, single and double shaker motor.
 - M2 White and black motor leads factory wired - double shaker motor only.
 - L1 Black 115-Volt line voltage IN, factory wired.
 - L2 White 115-Volt line voltage IN, factory wired.
- Note: In grounded systems, connect L2 to the transformer's 110-V neutral terminal.
- L3 Factory wired pressure switch.

Typical Wiring Diagram

Options and Accessories

Hopper Discharge Accessories

5-Gallon Pail Pack

1. Apply sealant to the hopper flange or the pail cover mounting plate flange toward the inside edge of the bolt pattern.
2. Fasten the pail pack to the hopper using the bolts, washers, and nuts supplied.
3. Place pail beneath seater mechanism.
4. Tighten clamps on either side by pulling down.

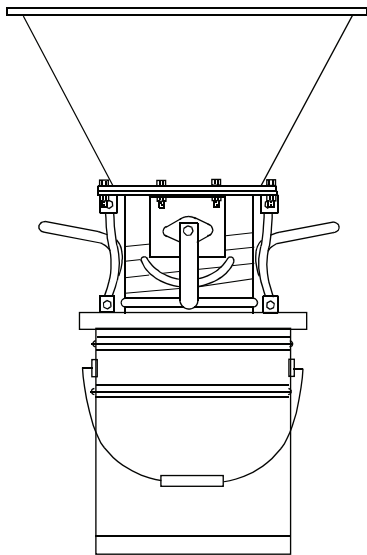

Pail Pack
with Gate Valve

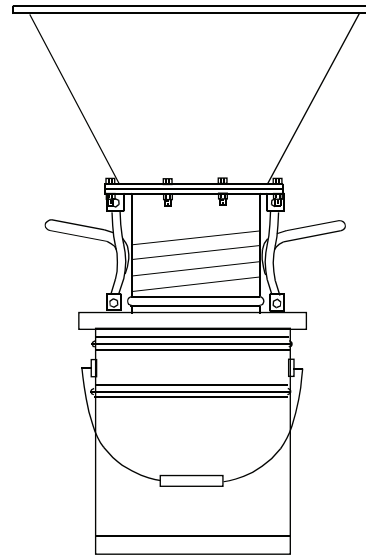

Pail Pack
without Gate Valve

5-Gallon Pail Pack with and without Slide Gate

55-Gallon Drum Pack



Sharp edge of slide gate may result in personal injury while closing the slide gate. Keep hands clear when operating the slide gate.

With Slide Gate

1. Place the 1/8-in gasket spacer between the hopper flange and slide gate as shown.
2. Attach the drum pack and slide gate to the hopper flange using 3/8-16 bolts, washers and hex nuts.
3. Attach the drum cover to the 55-gallon drum.
4. Use latches to secure the cover to the drum, if equipped.
5. Connect the flexible hose between the drum cover and slide gate. Secure with hose clamps.

Without Slide Gate

1. Place 1/4-in diameter rope-type sealant between the hopper flange and the drum cover mounting flange toward the inside edge of the bolt pattern.
2. Fasten using the bolts, washers, and nuts supplied.
3. Attach the drum cover to the 55-gallon drum.
4. Use latches to secure the cover to the drum, if equipped.
5. Connect the flexible hose between the drum cover and the adapter. Secure with hose clamps.

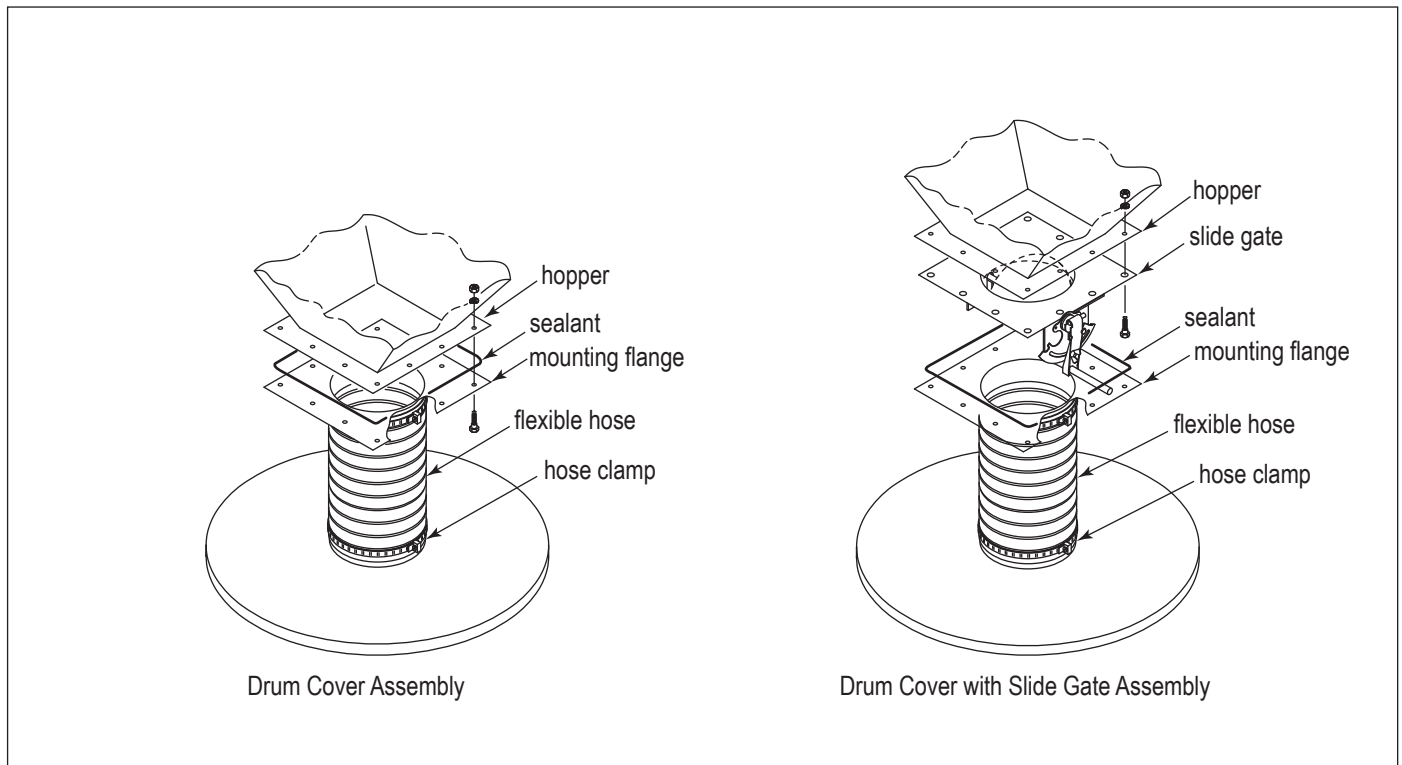

55-Gallon Drum Pack with and without Slide Gate

Control Box with Solid State Timer

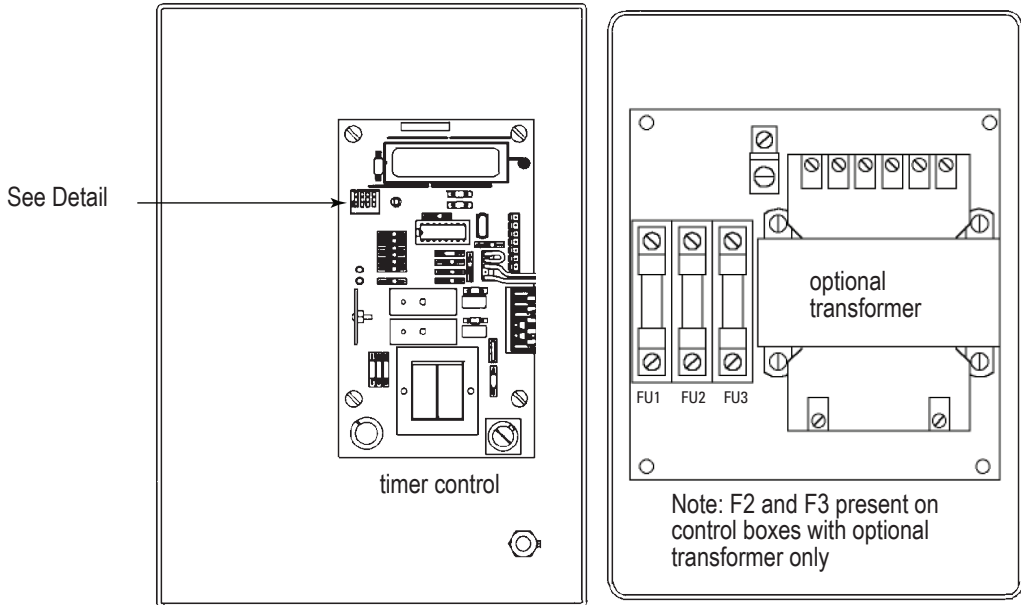

Control Box Assembly

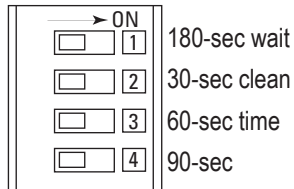

Single VS-550, 1200 and 1500
 Switches preset to OFF position
 Default set to 60-sec wait, 60-sec clean

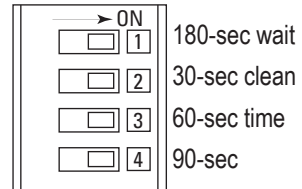

Double VS-2400 and 3000
 Switch 1 to ON position
 Set to 180-sec wait, default 60-sec clean

Control Box Assembly

Control Box with PLC

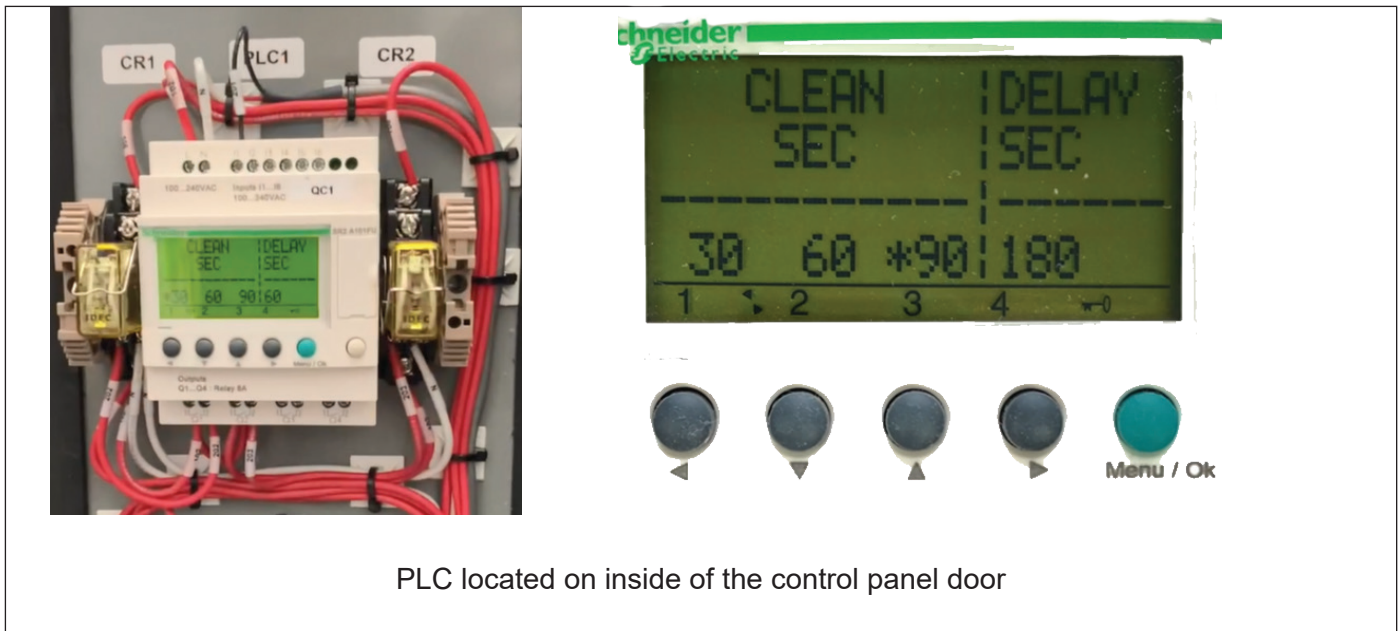

Clean Cycle Selection Instructions

Default delay time: 60 sec single shaker (VS-550, 1200, 1500), 180 sec dual shaker (VS-2400, 3000).

Default clean/shake time: 60 second dual and single shakers.

Power must be on the make selections.

A certified electrician should make selections as panel door must be open with panel on.

1. Turn fan OFF.
2. If PLC is in stop mode, see Stop Mode Recovery Instructions.
3. Select a clean/shake time of 30, 60 90 seconds by pressing the buttons under desired time in the clean section of the PLC. See PLC Selection Instructions for more details.
4. Select a delay time of 60 or 180 seconds by pressing the button in the delay section of the PLC. Delay time will toggle between 60 and 180 each time the button is pushed. See PLC Selection Instructions for more details.
5. Close and lock the control panel.
6. Turn fan on to continue normal dust collection.
7. Turn fan OFF to start cleaning cycle. Fan must run for at least 1 minute before turning off for cleaning cycle.

PLC Selection Instructions

Length of Shake Cycle

To select the length of the Shake Cycle, press the corresponding button on the face of the PLC to the number of seconds desired. 30, 60, or 90 seconds are selectable. The selection is set once the * is shown next to the number. Current selection is shown at 60 seconds.

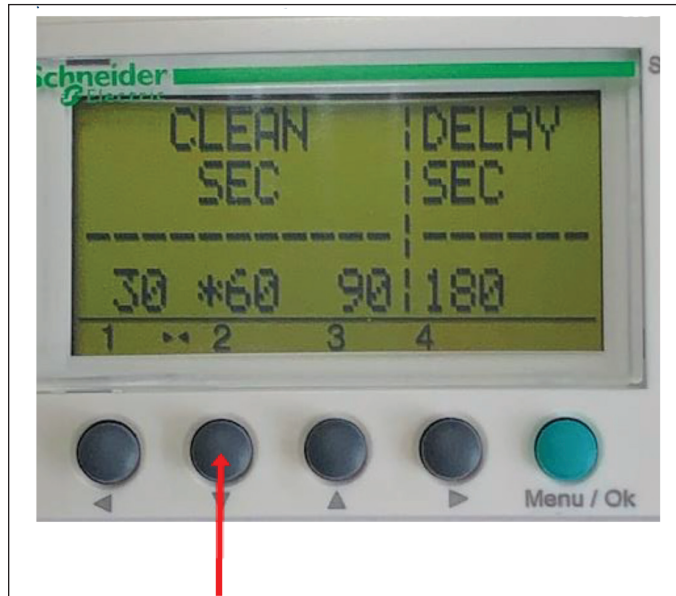

Delay Before Shake Cycle Begins

To select the length of the delay before the Shake Cycle begins. Pressing the DELAY SEC button (as indicated by the red arrow) toggles between 60 and 180 seconds of delay. Selection is set (no need to press any other buttons).

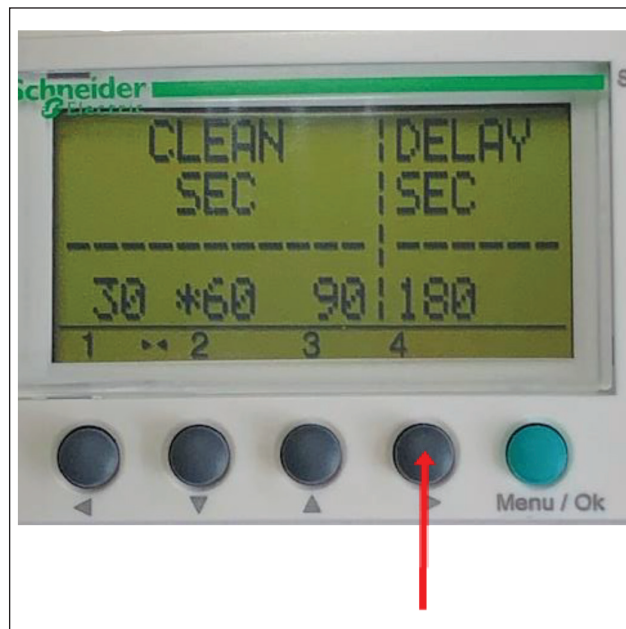

Stop Mode Recovery Instructions

PLC Screen

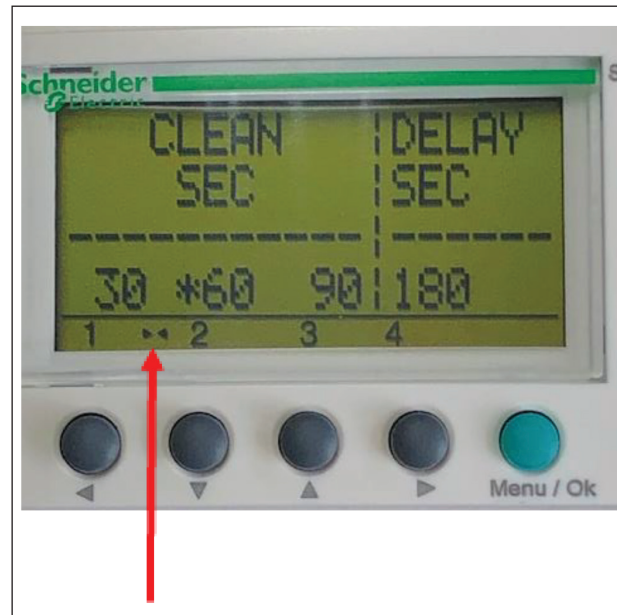

If these arrows are not spinning, this is an indication the PLC is in STOP mode.

To put the PLC back in RUN mode, press the green Menu/Ok button on the face of the PLC.

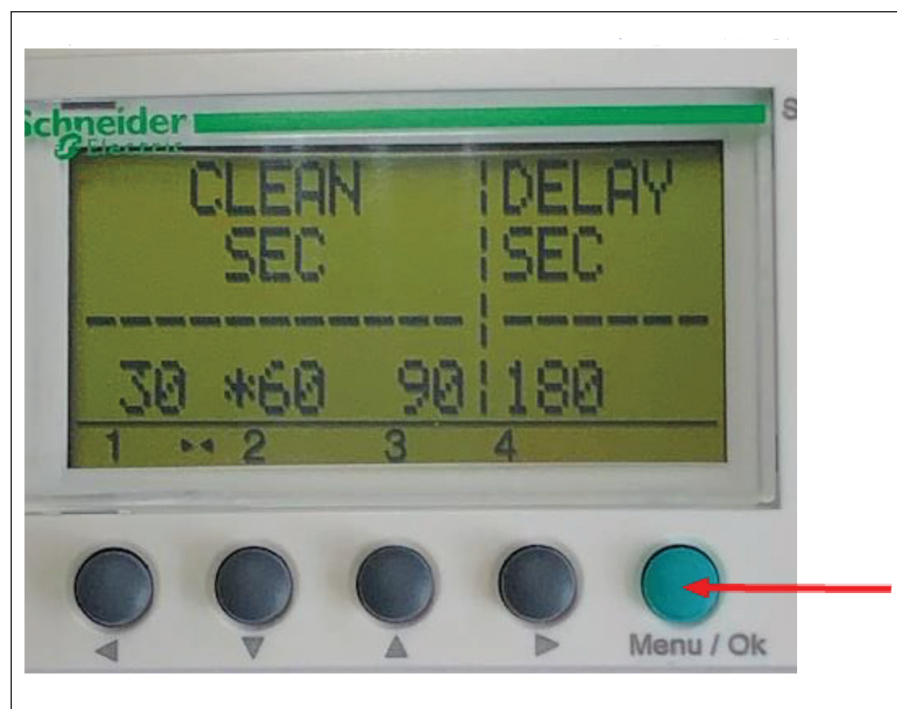

Press the down arrow key on the face of the PLC to select "RUN/STOP". When RUN/STOP is flashing, press the green "Menu/OK" button on the PLC.



The display will now show the screen below. The top menu option "WITH NONVOLAT INI" should be flashing. Press the green "MENU/OK" key to select this option.

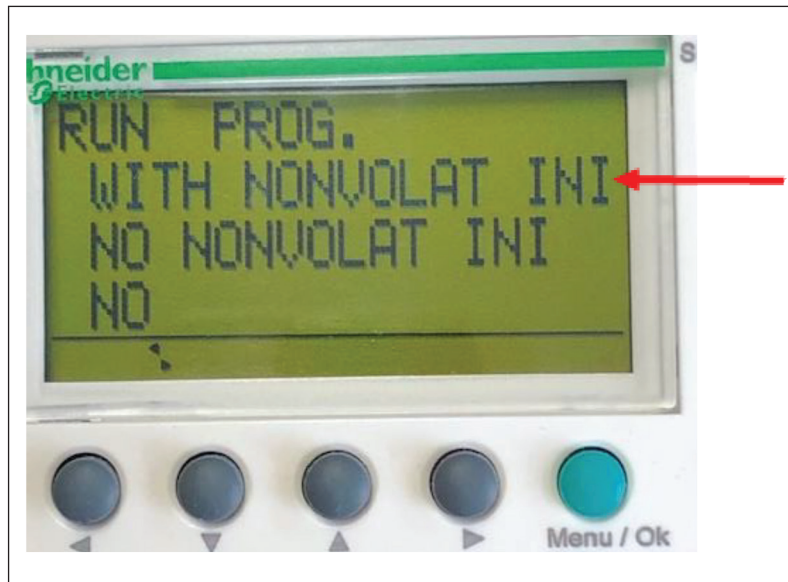

Shaker Assembly

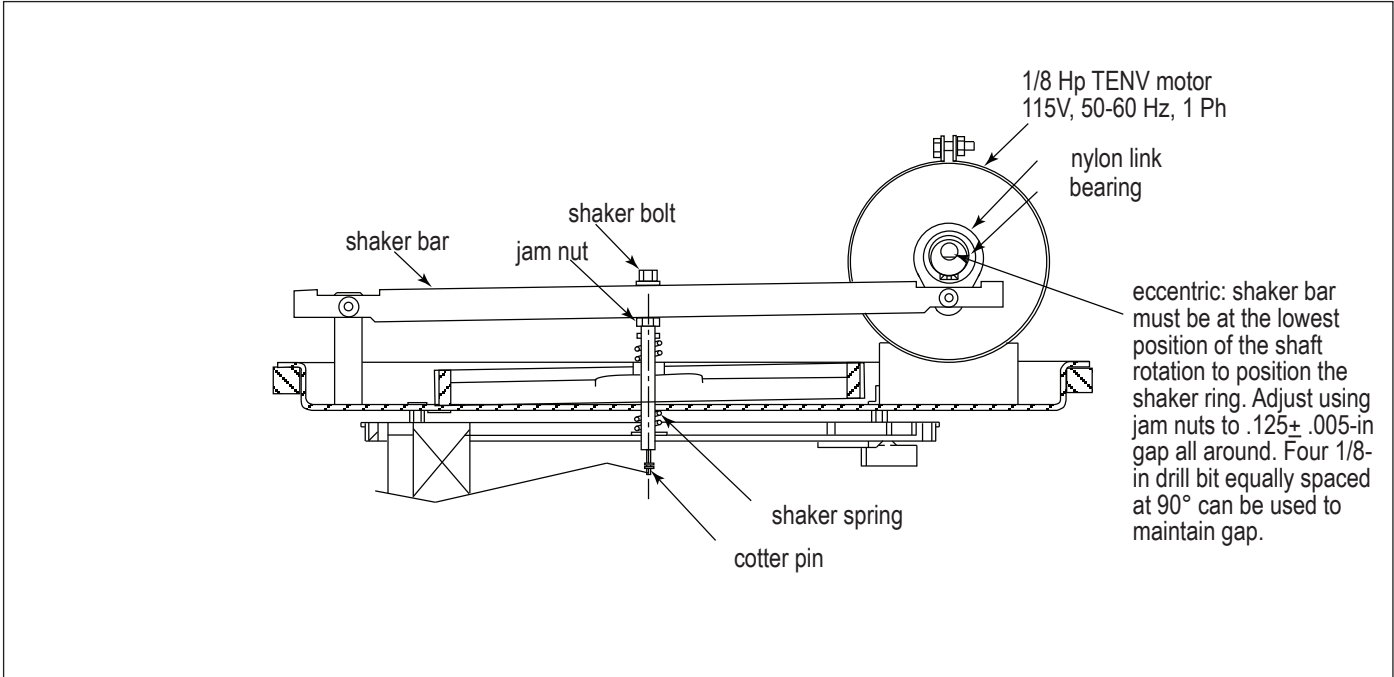

Single and Double Shaker Assembly

Pressure Switch Connection

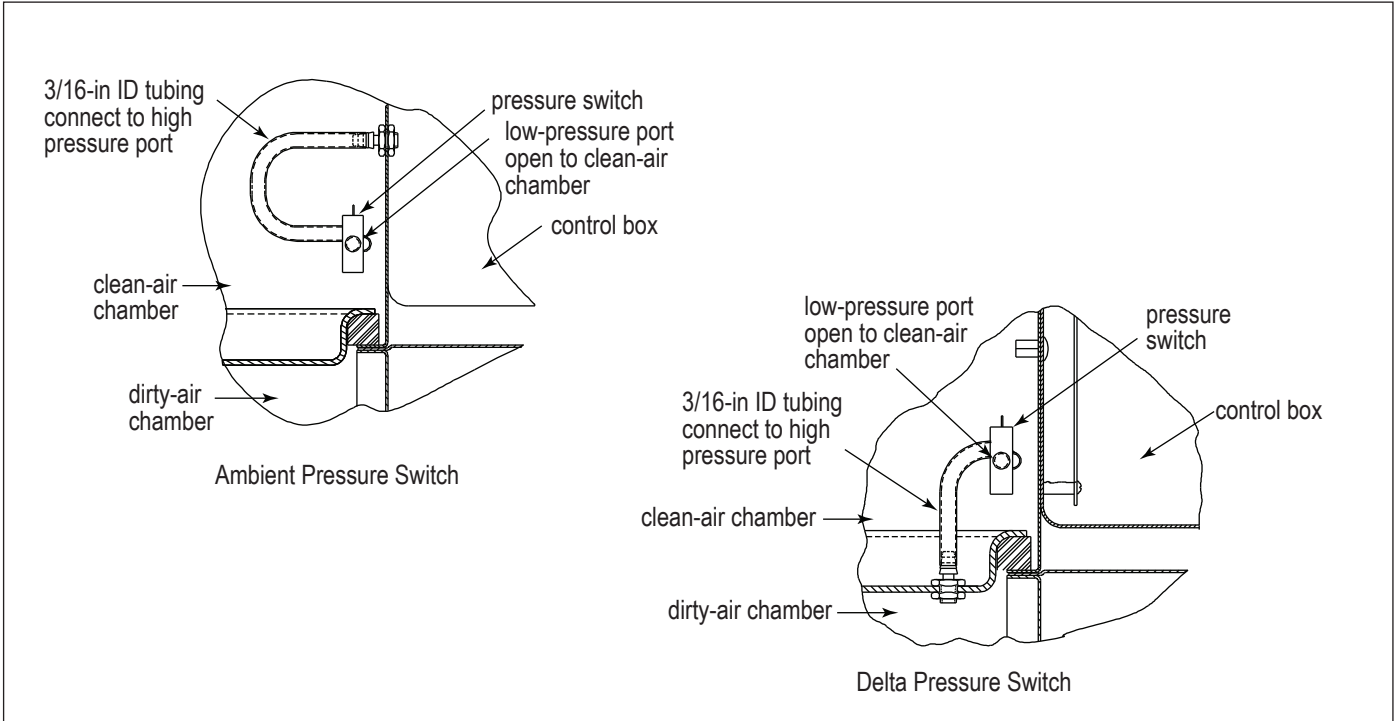

Pressure Switch Connection

Start-up / Commissioning

Instruct all personnel on safe use and maintenance procedures.



Electrical installation, service, or maintenance work must be performed by a qualified electrician and comply with all applicable national and local codes. This equipment may start or stop unexpectedly from a remote location.

Turn all power off and lock out all power before performing service or maintenance work.

Turn compressed air supply OFF, bleed and lock out lines before performing service or maintenance work.

Check that the collector is clear and free of all debris before starting.

Do not operate in classified hazardous atmospheres without an enclosure rated for the application.

Optional fans over 600 lbs must be independently supported.

1. Check all electrical connections for tightness and contact.
2. Check for proper rotation on all motors as described below.



Do not look into fan outlet to determine rotation. View the fan rotation through the back of the motor.

Check that the exhaust plenum is free of tools or debris before checking fan rotation.

Stand clear of exhaust to avoid personal injury.

Do not interchange a power lead with the ground wire. Severe personal injury and/or property damage may result.

- a. "Bump" the fan to initiate rotation.
 - b. As the fan is winding down () compare fan rotation to the rotation label (located on fan housing) direction.
3. If the fan rotation is reversed, correct the rotation.

To reverse rotation, single-phase power supply: Follow manufacturer's instructions on the motor's nameplate.

To reverse rotation, three-phase power supply: Switch any two leads on the motor junction box.

- a. Turn off the collector and Lock-Out all energy sources.
- b. Within the junction box, swap the connection location of two power leads on the terminal block, making certain not to swap a power lead and the ground wire.



Do not interchange a power lead with a ground wire or severe personal injury and/or property damage may result.

4. Check that the dust container is properly sealed and clamped.
5. Check and remove all loose items in or near the inlet and outlet of the collector.
6. Check that all remote controls and solenoid enclosures (if applicable) are properly wired and all service switches are in the OFF position.
7. Check that all optional accessories are installed properly and secured.
8. Turn power ON at source.
9. Turn fan motor ON.

Decommissioning Alternate

Once the collector has reached the end of operational life it will need to be decommissioned.



During decommissioning, there is potential for exposure to the dust in the collector. Most dusts present safety and health hazards that require precautions. Wear eye, respiratory, head, and other protection equipment suitable for the type of dust when performing any decommissioning activities.

LOCK-OUT all energy sources prior to performing any decommissioning activities on the equipment.

Electrical service must be performed by a qualified electrician.

Disconnection of ducts must be performed by a qualified contractor.

1. Lock-Out all energy sources to the collector, material handling system and other associated equipment.
2. Remove all filters from the collector and dispose of in a suitable fashion for the dust in the collector. (See Filter Replacement for removal instructions).
3. Disconnect electrical power from the collector and material handling system components and remove any associated conduit or from the exterior of the collector.
4. Disconnect all ducts from the collector.
5. Once all cross-bracing has been taken down, remove anchor bolts and lower leg pack columns.
6. Secure all collector components to a suitable transport carrier and transport to a disposal site suitable for the dust in the collector.

Product Information

(Process Owner to complete and retain for your records)

Model Number _____ Serial Number _____
Ship Date _____ Installation Date _____
Filter Type _____
Collected Dust _____
Dust Properties: Kst _____ Pmax _____ MIE _____ MEC _____
Accessories _____
Other _____

Service Notes

Date	Service Performed	Notes
------	-------------------	-------

Donaldson Industrial Air Filtration Warranty

Donaldson warrants to the original purchaser only that the Goods will be free from defects in material and manufacture for the applicable time periods stated below: (1) Major structural components for a period of ten (10) years from the date of shipment; (2) Non-Structural, Donaldson-built components and accessories including Donaldson Airlocks, TBI Fans, TRB Fans, Fume Collector products, Donaldson built electrical control components, and Donaldson-built Afterfilter housings for a period of twelve (12) months from date of shipment; and (3) Donaldson-built filter elements for a period of eighteen (18) months from date of shipment.

Buyer is solely responsible for determining if goods fit Buyer's particular purpose and are suitable for Buyer's process and application. Seller's statements, engineering and technical information, and recommendations are provided for the Buyer's convenience and the accuracy or completeness thereof is not warranted. If, after Seller receives written notice, within the warranty period, that any goods allegedly do not meet Seller's warranty, and Seller, in its sole discretion, determines that such claim is valid, Seller's sole obligation and Buyer's exclusive remedy for breach of the foregoing warranty or any Seller published warranty, will be, at Seller's option, either: (i) repair or replacement of such goods or (ii) credit or refund to Buyer for the purchase price from Seller. In the case of repair or replacement, Seller will be responsible for the cost of shipping the parts but not for labor to remove, repair, replace or reinstall the allegedly defective goods. Refurbished goods may be used to repair or replace the goods and the warranty on such repaired or replaced goods shall be the balance of the warranty remaining on the goods which were repaired or replaced. Any repair or rework made by anyone other than Seller is not permitted without prior written authorization by Seller, and voids the warranty set forth herein. Seller warrants to Buyer that it will perform services in accordance with the Sales Documents using personnel of required skill, experience and qualifications and in a professional and workmanlike manner in accordance with generally recognized industry standards for similar services. With respect to any services subject to a claim under the warranty set forth above, Seller shall, in its sole discretion, (i) repair or re-perform the applicable services or (ii) credit or refund the price of such services at the pro rata contract rate and such shall be Seller's sole obligation and the exclusive remedy for breach of the foregoing warranty on services. Products manufactured by a third party ("Third Party Product") may constitute, contain, be contained in, incorporated into, attached to or packaged together with, the goods. Buyer agrees that: (a) Third Party Products are excluded from Seller's warranty in this Section 7 and carry only the warranty extended by the original manufacturer, and (b) Seller's liability in all cases is limited to goods of Seller's design and manufacture only. EXCEPT FOR SELLER'S WARRANTY OF TITLE TO THE GOODS, SELLER EXPRESSLY DISCLAIMS AND EXCLUDES ALL OTHER WARRANTIES WHATSOEVER, WHETHER, EXPRESSED OR IMPLIED, ORAL, STATUTORY, OR OTHERWISE, INCLUDING BUT NOT LIMITED TO MERCHANTABILITY, FITNESS FOR A PARTICULAR PURPOSE, NON-INFRINGEMENT OF THIRD PARTY INTELLECTUAL PROPERTY AND ANY WARRANTIES ARISING FROM TECHNICAL ADVICE OR RECOMMENDATIONS, COURSE OF DEALING OR OF PERFORMANCE, CUSTOM OR USAGE OF TRADE. Seller's obligations do not cover normal wear and tear or deterioration, defects in or damage to any goods resulting from improper installation, accident or any utilization, maintenance, repair or modification of the goods, or any use that is inconsistent with Seller's instructions as to the storage, installation, commissioning or use of the goods or the designed capabilities of the goods or that, in its sole judgment, the performance or reliability thereof is adversely affected thereby, or which is subjected to abuse, mishandling, misuse or neglect or any damage caused by connections, interfacing or use in unforeseen or unintended environments or any other cause not the sole fault of Seller, and shall be at Buyer's expense. Seller's warranty is contingent upon the accuracy of all information provided by Buyer. Any changes to or inaccuracies in any information or data provided by Buyer voids this warranty. Seller does not warrant that the operation of the goods will be uninterrupted or error-free, that the functions of the goods will meet Buyer's or its customer's requirements unless specifically agreed to, or that the goods will operate in combination with other products selected by Buyer or Buyer's customer for its use.

The terms of this warranty may only be modified by a special warranty document signed by a Director, General Manager or Vice President of Donaldson. To ensure proper operational performance of your equipment, use only genuine Donaldson replacement parts.

This Product is provided subject to and conditioned upon Donaldson's Terms of Sale ("Terms"), a current copy of which is located at termsofsale.donaldson.com. These Terms are incorporated herein by reference. By purchasing or using this Product, the user accepts these Terms. The Terms are available on our website or by calling our customer service line at 1-800-365-1331.

Significantly improve the performance of your collector with genuine Donaldson Torit replacement filters and parts. **Call Donaldson Torit at 800-365-1331.**

Important Notice: Many factors beyond the control of Donaldson can affect the use and performance of Donaldson products in a particular application, including the conditions under which the product is used. Since these factors are uniquely within the user's knowledge and control, it is essential the user evaluate the products to determine whether the product is fit for the particular purpose and suitable for the user's application. All products, product specifications, availability and data are subject to change without notice, and may vary by region or country.



Donaldson.

Donaldson Company, Inc.
Minneapolis, MN
donaldsontorit.com • shop.donaldson.com

North America
Email: donaldsontorit@donaldson.com
Phone: (USA): +1-800-365-1331 • (MX): +1-800-343-3639

Australasia
Email: marketing.australia@donaldson.com
Phone: +61-2-4350-2000
Toll Free: (AU) +1800-345-837 • (NZ) +0800-743-387

China
Email: info.cn@donaldson.com
Phone: +86-400-820-1038

Donaldson Europe B.V.B.A
Email: IAF-europe@donaldson.com
Phone: +32-16-38-3811

India
Email: info.dfis@donaldson.com
Phone: +91-124-4807-400 • +1-800-103-5018

Japan
Email: jp-ndl.ifswweb@donaldson.com
Phone: +81-42-540-4112

Korea
Email: iaf-kr@donaldson.com
Phone: +82-2-517-3333

Latinoamerica
Email: IndustrialAir@donaldson.com
Phone: +52-449-300-2442

South Africa
Email: SAMarketing@donaldson.com
Phone: +27 11 997 6000

Southeast Asia
Email: IAF.SEA@donaldson.com
Phone: (65) 63117373

IOM 4077700 (ENG), Revision 12 (January 2022) ©2002 Donaldson Company, Inc. Donaldson, Torit, and the color blue are marks of Donaldson Company, Inc. All other marks belong to their respective owners.