



Donaldson  
FILTRATION SOLUTIONS

## DATA SHEET

### Replacement Elements

Cartridges – Square Flange (426 × 533) – Open Closed

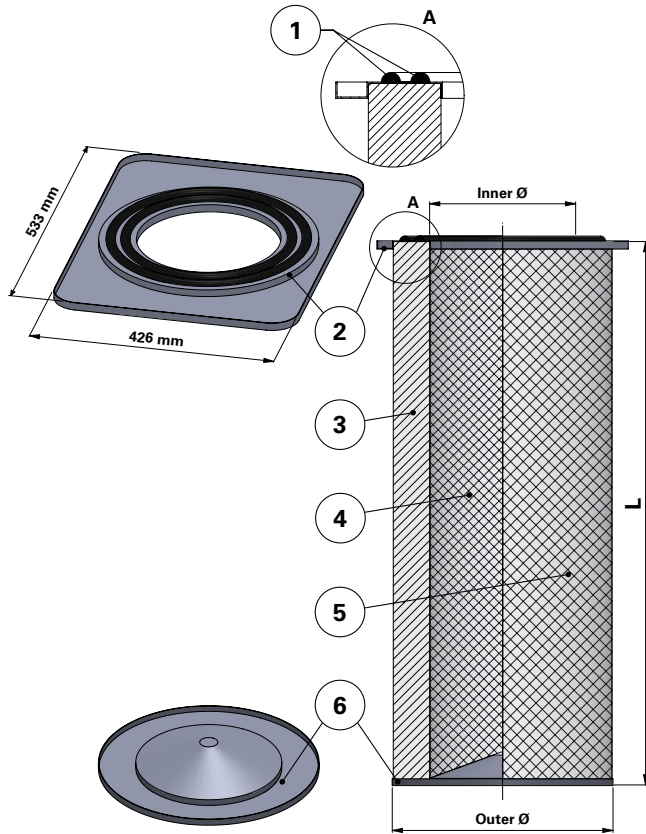
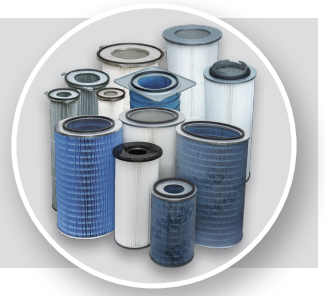

### Square Flange (426 × 533) – Open Closed

Cartridge Filter with square top end cap with 426 mm by 533 mm rectangle flange

Special feature: Double gasket for Camfil and other brands of cartridge collectors

With outer liner

Item	Description
1	Gaskets
2	Top flange
3	Media pack
4	Inner liner
5	Outer liner
6	Bottom end cap closed

#### Dimensions [mm]

Outer Ø	380
Inner Ø	248
L	995
Flange	426 × 533

Order online

shop.Donaldson.com

Contact us

Donaldson.com

Publication DOCAM0827701 • Rev. 00 • 0218

Donaldson reserves the right to change or discontinue any model or specification at any time and without notice. Freedom from patent restrictions must not be assumed.