



HPK02

Max Flow: 20 gpm (76 lpm)



## HPK02 In-Line Cartridge Filters

### Working Pressures to:

2000 psi / 13,790 kPa / 137.9 bar

### Rated Static Burst to:

4500 psi / 31,030 kPa / 310.3 bar

### Flow Range To:

20 gpm / 76 lpm

### Applications

- High Pressure Circuits
- In-Plant Systems
- Meets HF2 Specification
- Mobile Equipment
- Power Steering Circuits
- Servo Valve Circuits

### Features

The HPK02 is a heavy-duty filter built for high pressure applications, with cast aluminum head and impact-extruded aluminum housing for strength and durability at relatively lightweight.

Take advantage of our mix and match system of in-stock heads, housings and cartridges – so you can get exactly what you need. HPK02 is available with your choice of visual or AC/DC electrical indicators. Likewise, choose the bypass option that's right for your application – 50 psi (3.5 bar) bypass, or no bypass. Seals made of fluorocarbon or nitrile are available with HPK02.

All HF2-sized HPK02 filters contain Synteq™, our synthetic filter media designed especially for hydraulic filtration.



### Beta Rating

- Performance to  $\beta_{<40} = 1000$

### Porting Size Options

- SAE-12 O-Ring

### Replacement Filter Lengths

- 4.37" / 111mm
- 8.12" / 206mm

### Standard Bypass Ratings

- 50 psi / 345 kPa / 3.5 bar
- No Bypass

### Assembly Weight

- 4.3 lbs / 1.95 kg (short)
- 5.5 lbs / 2.49 kg (long)

### Operating Temperatures

- -45° to 250°F (-43° to 121°C)

### Filter Collapse Ratings

- 290 psi / 1999 kPa / 20.0 bar (standard)
- 3000 psi / 20,700 kPa / 206.9 bar (high collapse)

## HPK02 Specification Illustrations

### ASSEMBLY - SIDE VIEW

All dimensions are shown in inches [millimeters].

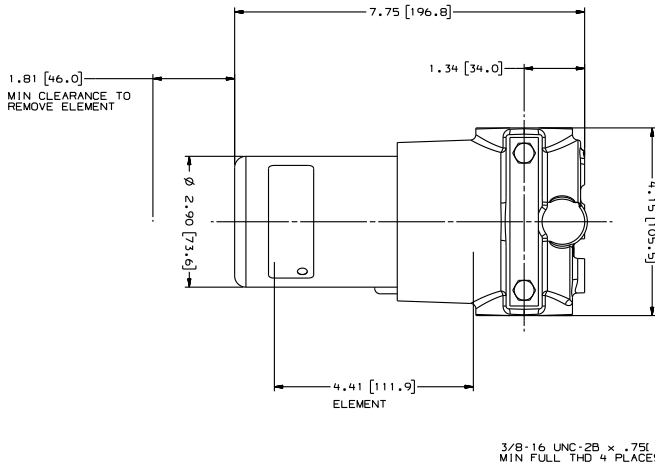

### HEAD - TOP VIEW

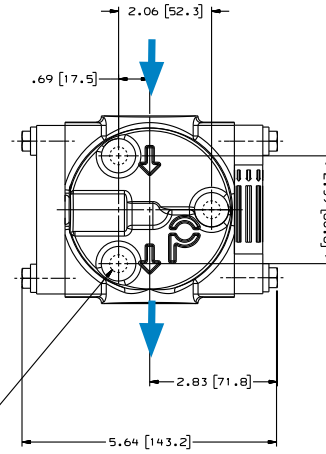

### HPK02 with Visual Service Indicator

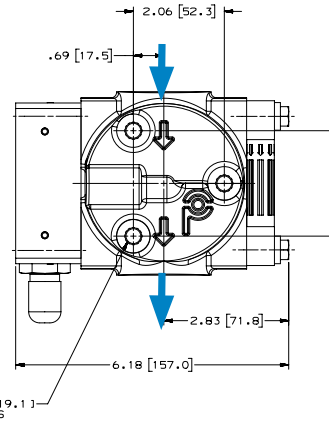
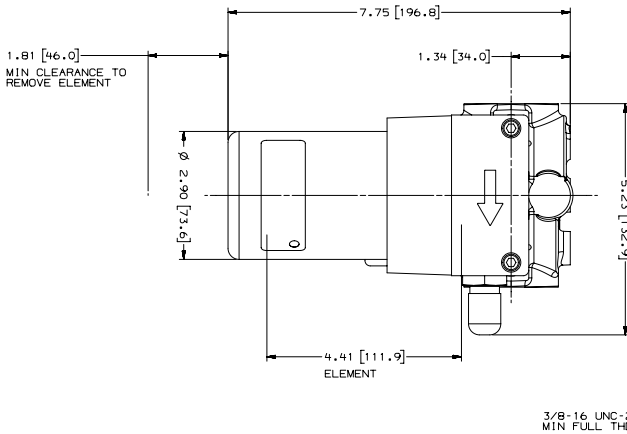

### HPK02 with AC/DC Electrical Service Indicator

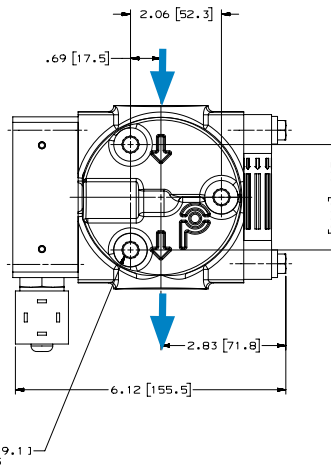
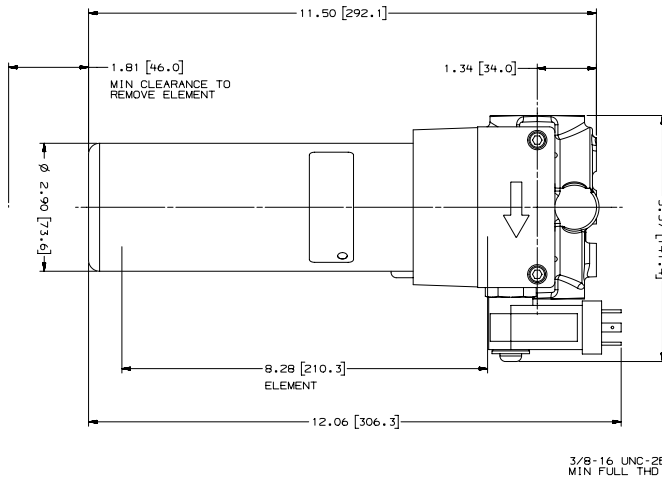



HPK02

Max Flow: 20 gpm (76 lpm)



## HPK02 Components

### Filter Choices

Media Type	$\beta_{x(e)} = 1000$	Length		Part No.	Comments
	Rating based on ISO 16889	in	mm		
DT Synthetic	<4 $\mu\text{m}$	4.39	112	P566194	DT-9020-4-2UM
	5 $\mu\text{m}$	4.39	112	P566195	DT-9020-4-5UM
	5 $\mu\text{m}$	4.46	113	P167180	DT-9021-4-5UM, High Collapse
	8 $\mu\text{m}$	4.39	112	P566196	DT-9020-4-8UM
	12 $\mu\text{m}$	4.39	112	P566197	DT-9020-4-14UM
	12 $\mu\text{m}$	4.46	113	P167181	DT-9021-4-14UM, High Collapse
	23 $\mu\text{m}$	4.39	112	P566198	DT-9020-4-25UM
	<4 $\mu\text{m}$	8.18	208	P566199	DT-9020-8-2UM
	5 $\mu\text{m}$	8.18	208	P566200	DT-9020-8-5UM
	5 $\mu\text{m}$	8.18	208	P167182	DT-9021-8-5UM, High Collapse
	8 $\mu\text{m}$	8.18	208	P566201	DT-9020-8-8UM
	12 $\mu\text{m}$	8.18	208	P566202	DT-9020-8-14UM
	12 $\mu\text{m}$	8.18	208	P167183	DT-9021-8-14UM, High Collapse
	23 $\mu\text{m}$	8.18	208	P566203	DT-9020-8-25UM

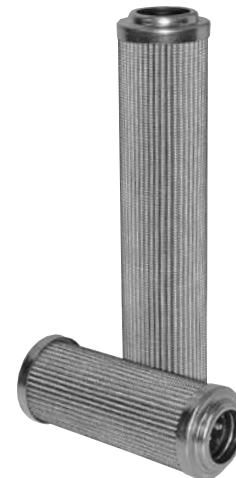

Filter Notes: All Donaldson DT filters utilize glass fiber media with an acrylic-based resin system for the ultimate in chemical compatibility. All Donaldson DT filters are potted with acrylic-based adhesives. Standard collapse DT designs are double wire-backed using acrylic-coated steel mesh for maximum pleat support and dirt capacity. Refer to the table in the Technical Reference Guide for fluid compatibility with our filter media. If filtering diester, phosphate ester fluids, water glycol, water/oil emulsions, or HWCF over 150°F/83°C, use filters with seals made of fluorocarbon. Donaldson "high collapse" filters, with their steel end caps and wire-backed media, are rated to withstand up to 3000 psi/ 20,700 kPa before collapsing. High collapse designs are also potted into machined aluminum endcaps for greater filter integrity in critical applications. The fluorocarbon seal/high collapse filters also use acrylic potting and media seam seals for added chemical compatibility. High collapse designs are double wire-backed using stainless steel mesh.

### Housing Choices

Length	Part No.
Short	P167443
Long	P167452

### Head Choices

Port Size	Bypass Rating	Indicators'	Part No.
SAE-12 O-Ring	50 psi/3.5 bar	Visual indicator, left side	P167728
SAE-12 O-Ring	No bypass	Visual indicator, left side	P167730

Notes on Indicators: Donaldson uses the inlet port as the reference point. "Left side," for instance, means that the indicator mounts on the side of the filter head that is on your left when you face the inlet port.

### Service Indicator Kits (All kits include indicator with mounting block)

Part No.	Bypass Valve Pressure of:	Description
<b>Visual Service Indicators</b>		
P569632	60 psi / 4.1 bar	35 psi/2.4 bar indicator kit auto reset pop-out button
P569633	90 psi / 6.2 bar	70 psi/4.8 bar indicator kit auto reset pop-out button
P567988	60 psi / 4.1 bar	35 psi/2.4 bar indicator kit auto reset pop-out button with thermal lockout and surge control
P567989	90 psi / 6.2 bar	70 psi/4.8 bar indicator kit* auto reset pop-out button with thermal lockout and surge control
<b>AC/DC Visual/Electrical Service Indicators</b>		
P569634	60 psi / 4.1 bar	35 psi/2.4 bar indicator kit Hirschmann receptacle 115 VAC/28 VDC, 2 amps
P569635	90 psi / 6.2 bar	70 psi/4.8 bar indicator kit Hirschmann receptacle 115 VAC/28 VDC, 2 amps
P567986	60 psi / 4.1 bar	35 psi/2.4 bar indicator kit with thermal lockout and surge control, Hirschmann receptacle, 115 VAC/28 VDC, 2 amps, 4 pin DIN 43650
P567987	90 psi / 6.2 bar	70 psi/4.8 bar indicator kit with thermal lockout and surge control, Hirschmann receptacle, 115 VAC/28 VDC, 2 amps, 4 pin DIN 43650



### Indicator Choices (Replacement Indicator Only)

Part No.	Description	Part No.	Description
P567458	Visual/Electrical indicator with thermal lockout and surge, 35 psid/2.4 bar	P569638	Visual/Electrical Indicator, 35 psid/2.4 bar
P567459	Visual/Electrical indicator, with thermal lockout and surge, 70 psid/4.8 bar	P569639	Visual/Electrical Indicator, 70 psid/4.8 bar
P567456	Pop-Up Visual Indicator, with thermal lockout and surge, 35 psid/2.4 bar	P164315	Visual Indicator, bar style, 35 psid/2.4 bar
P567457	Pop-Up Visual Indicator, with thermal lockout and surge, 70 psid/4.8 bar	P166603	Visual Indicator, bar style, 70 psid/4.8 bar
P569636	Pop-Up Visual Indicator, 35 psid/2.4 bar	P166134	Blanking plate
P569637	Pop-Up Visual Indicator, 70 psid/4.8 bar		

Indicator Mounting Block	
P573495	Mounting Block Assembly

### Performance Data



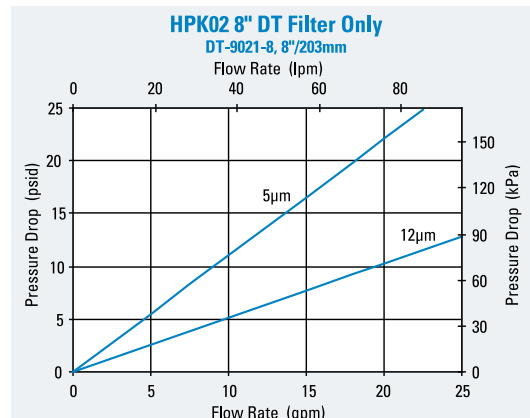
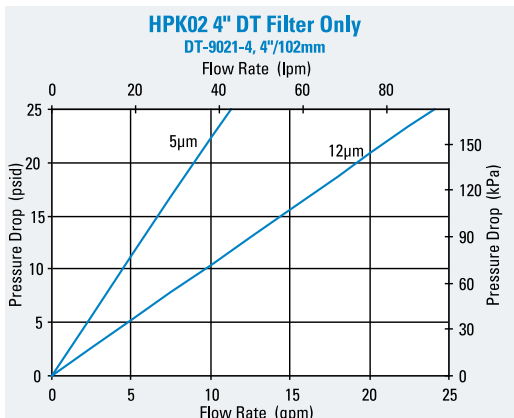
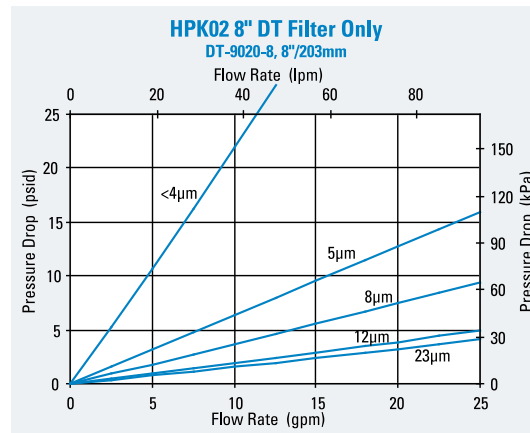
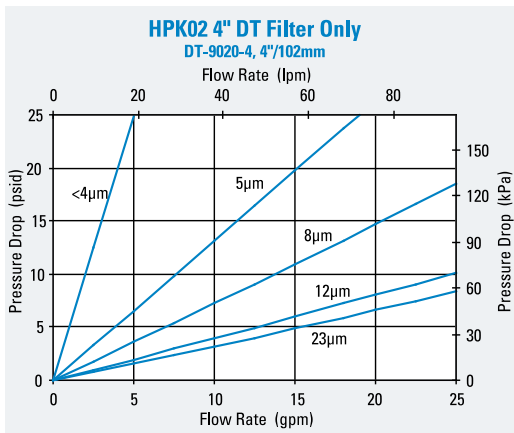
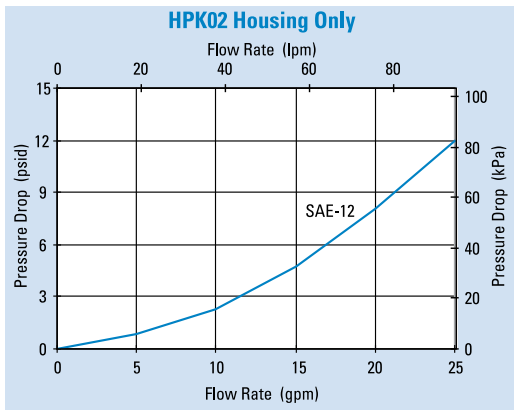

HPK02

Max Flow: 20 gpm (76 lpm)



# HPK02 Service Parts

**SERVICE PARTS NOTE:**

Some service parts may not be stocked. Please contact your Donaldson sales representative for lead time details.

