



The All-in-One STB Strata™ System Air Cleaner and Pre-Cleaner In One Package

Applications

- Allows 1050 to 1400 cfm airflow throughput per air cleaner
- For severe dust conditions, usually off-road applications: crawler tractors, scrapers, loaders, large agricultural tractors
- Horizontal installation

Air Cleaner Features

- Air cleaner and pre-cleaner in one package (exhaust ejector, scavenge hose and clamps sold separately)
- Pre-cleaned dust is ejected with the engine exhaust through an aspirated muffler or exhaust ejector
- Airflow pattern "B" air through the pre-cleaner, out the end of the air cleaner
- Perfect for:
 - turbocharged engines
 - intercooled engines
 - naturally aspirated engines
- Fitting for filter service indicator on all models
- Finished in corrosion-resistant paint
- Weight: 78 lbs. (35.4 kg)



The STB Strata™ System protects heavy-duty engines (like this one operating in severe dust conditions) with two-stage filtration and the convenience of aspirated dust ejection.

Ejector muffler, hose and clamps not included with B160071 — order parts separately.

Filter Features

- Two replacement filter choices: standard life filter for shops that service air cleaners on scheduled maintenance (shipped with STB initially), or extended life filter for those who measure restriction to obtain full filter life
- Safety filter on all models provide continuous protection during primary filter change out

For installation instructions on the STB system, see the Technical Reference section.

How the STB System Works

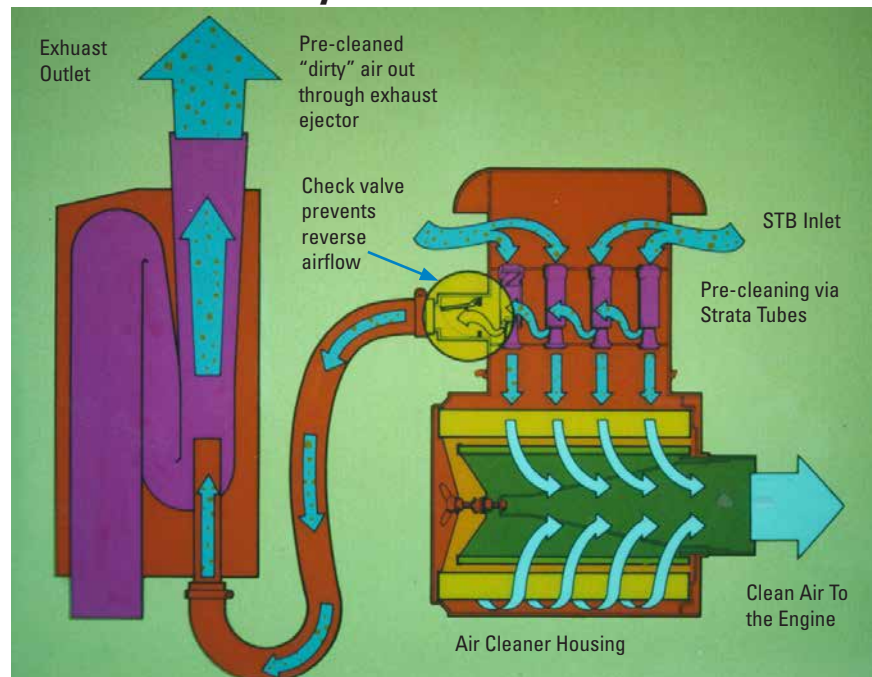

When Selecting an Air Cleaner . . .

Determine the airflow requirements of your engine, then find the corresponding cfm airflow in the table at right. The restriction numbers (shown in inches of water) indicate the approximate initial restriction of each model air cleaner at that cfm. If there are two air cleaner models that fit your parameters, choosing the one with the lower restriction will provide longer filter service life. When calculating total initial restriction of the entire air intake system, include the restriction caused by ducting, elbows, and pre-cleaners. See pages 257-258 for ducting restriction estimates.

Initial Airflow Restriction

6"	CFM @ "H ₂ O		Air Cleaner Model
	8"	10"	
1050	1225	1400	B160071

Airflow Pattern "B"

Air in through the pre-cleaner, out the end of the air cleaner (lower) portion.

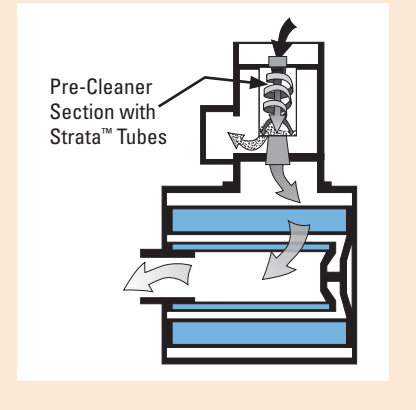

STB Air Cleaner Performance Curve (Restriction & Dust Capacity)*

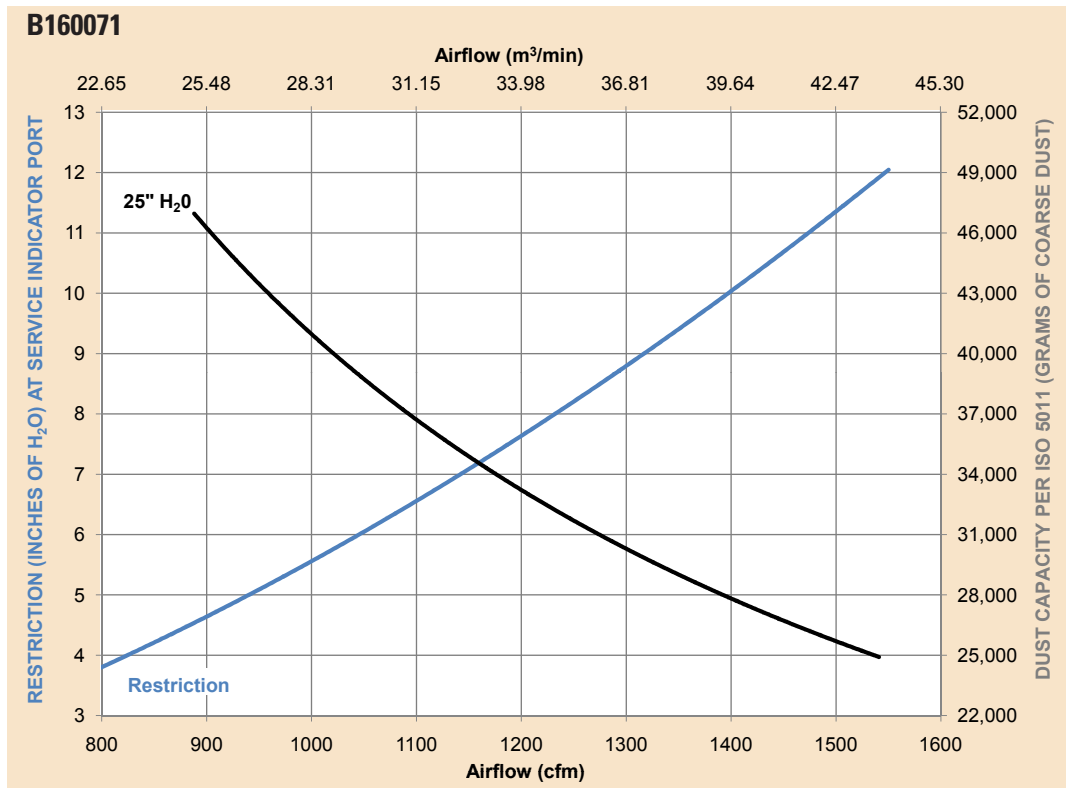

*Results generated using laboratory testing pursuant to ISO5011. Actual performance during use may vary depending on multiple factors, including specific product configuration, external conditions and application.



STB B160071 Specifications

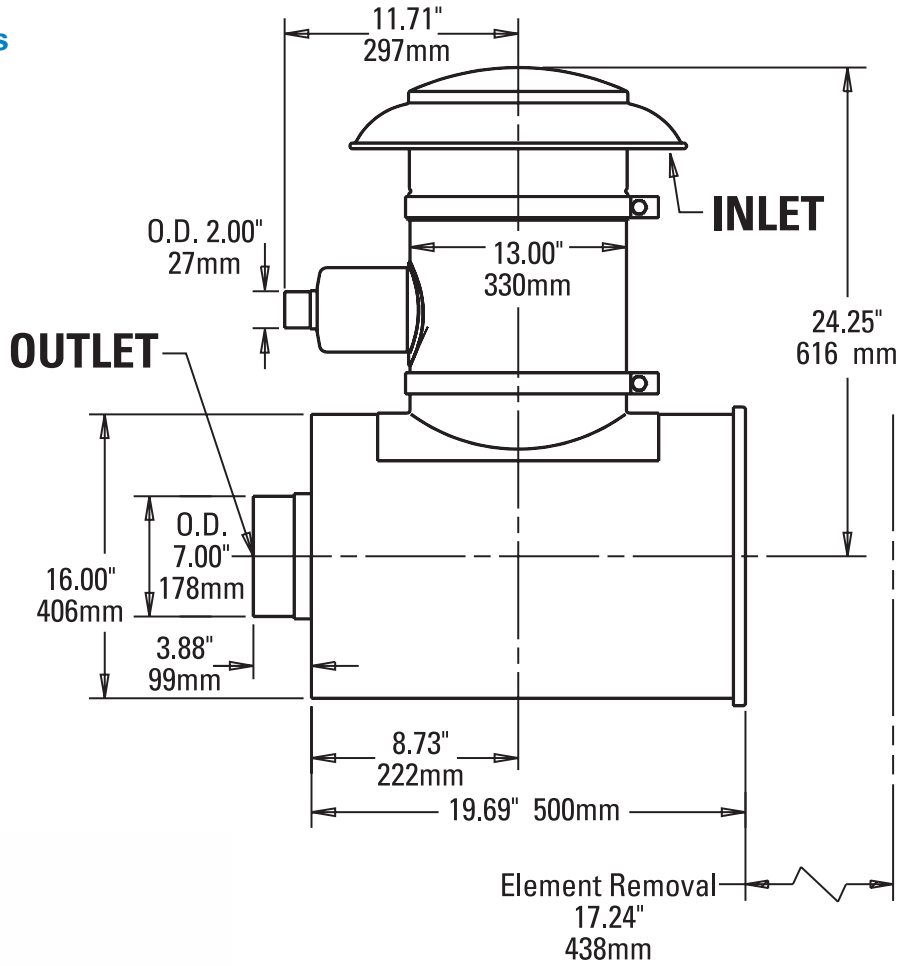

B160071 Service Parts

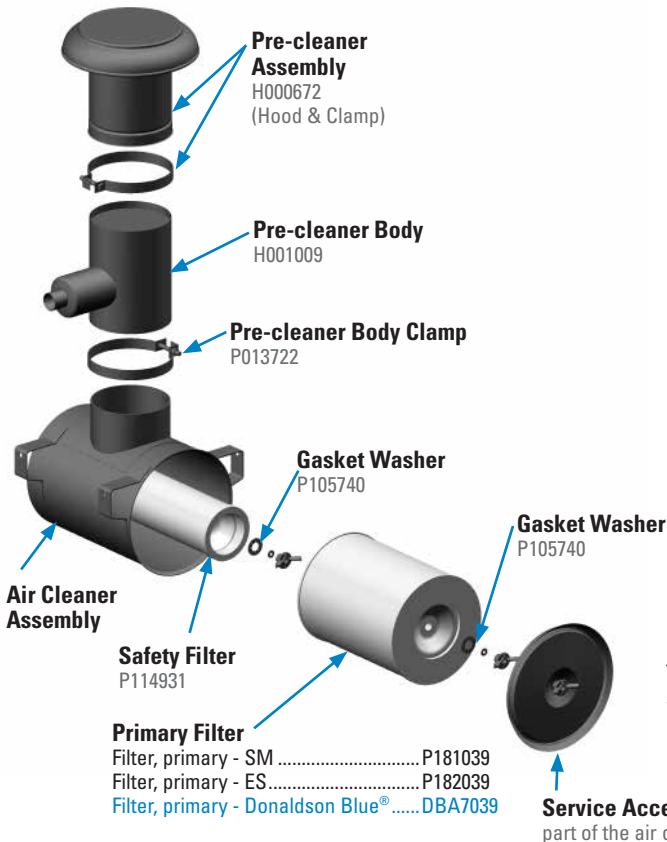

The STB is tapped to accept a filter service indicator

SM = Scheduled Maintenance
 ES = Extended Service
 Donaldson Blue® = High Efficiency, Extended Service