



## Donaldson Delivers **Reservoir Air Dryer** Clean Fuel & Lubricant Solutions

### Dry Fluid Is Better

Water/moisture in fluid tanks and reservoirs is a big problem. It creates corrosion, pump cavitation, viscosity changes, additive dropout, oxidation and a host of other major system issues. Our new **Reservoir Air Dryer** removes damaging water, while eliminating the need to continually replace conventional desiccant breathers, or to dry fluids with vacuum dehydration units.

**How it works.** The **Reservoir Air Dryer** combats ambient ingress of moisture by introducing a steady flow of clean, dry air to the reservoir/tank. This flow of air keeps the relative humidity low in the headspace, driving moisture from the fluids and preventing condensation.

**Easy Installation.** With no electrical hookups, installation is easy. Just connect compressed air to the inlet and the outlet to the top of the reservoir. A coalescing pre-filter (the only part that needs servicing – takes seconds to replace) and outlet regulator are pre-installed.

**Don't Forget The T.R.A.P.™.** When you combine the **Reservoir Air Dryer** with a T.R.A.P. Breather – the complete system keeps moisture and contamination out, even if fluid flow rate out of the tank surpasses the Reservoir Air Dryer flow rate into the tank. The Reservoir Air Dryer also regenerates the T.R.A.P. Breather, increasing life and reducing the total cost of ownership.

If you've got a water problem in your reservoirs or storage tanks, or would like to prevent moisture from entering your system, contact your Donaldson distributor or representative for a complete site audit or for more information.



## Features of the Donaldson Reservoir Air Dryer

- Designed to operate with *Standard Plant Air* — instrument quality air is not required!
- *Submicron Coalescing Air Filter* — collects oil and water droplets and fine particles present in the inlet air.
- *Automatic Drain* — purges captured liquid. No intervention required
- *Visual Indicator* — monitors filter condition
- *Membrane Air Dryer* — reduces the plant air dew point by as much as 150°F (66°C)
- *Pressure Regulator* — depressurizes the air and ensures that the proper volume of air is introduced into the reservoir
- The *Clean Dry Air Sweep* dehydrates the reservoir headspace and removes dissolved moisture from exposed oils and fuels\*



## P575852 - Reservoir Air Dryer

Specifications	
Efficiency	Reduces dew point as much as 150°F (66°C)
Fluid Compatibility	Petroleum & Phosphate Ester Fluids, Diesel Fuels*
Outlet Flow Volume @100 psi and dew point suppression	0.5 scfm (14.2 slpm) maximum
Inlet Air required @ 100 psi	0.8 scfm (22.7 slpm) maximum
Inlet/Outlet	¼" NPT
Pre-Filter Condition	Visual Indicator (Green/Red)
Pressure Regulator	Dial Gauge
Drain Plug	¼" NPT
Coalescer Drain	Automatic Float Type
Electrical	N/A
Max Working Pressure	116 psi (800 kPa / 8.00 bar)
Max Operating Temperature	125°F (52°C)
Mounting Bracket	3/8" - 16 UN Threaded Nut
Weight	<5 lbs (<3kgs)

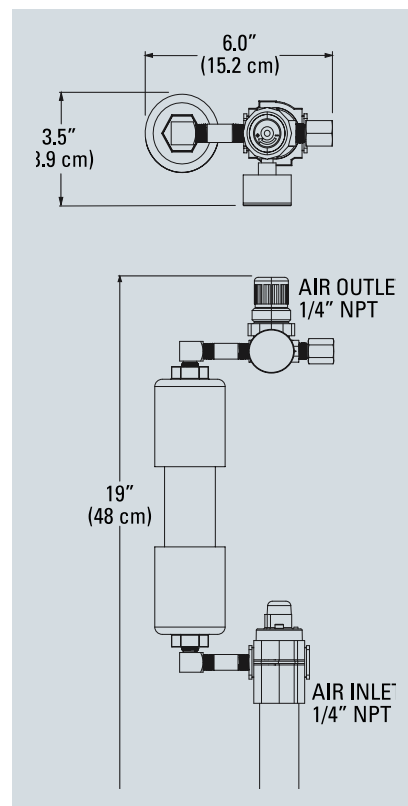

\*The Reservoir Air Dryer is not recommended for use on gasoline holding tanks, or for the head space of any flammable liquid (Flash Point below 100°F / 38°C)



Donaldson Company, Inc.  
Minneapolis, MN

[donaldson.com](http://donaldson.com)  
[shop.donaldson.com](http://shop.donaldson.com)

North America 800-374-1374  
Mexico, Latin America, &  
Caribbean 52-449-300-2400  
Brazil 55-11-4894-6339  
Europe 32-16-38-3811  
South Africa 27-11-997-6000

Southeast Asia 65-6311-7373  
Greater China 86-400-650-0610  
Japan 81-42-540-4112  
Korea 82-2-517-3333  
Australasia 61-02-4350-2033  
India 91-124-4807-400

Brochure No. F111427 ENG (4/18)

© 2018 Donaldson Company, Inc. All rights reserved.  
Donaldson Company, Inc. reserves the right to change or discontinue any model or specification at any time and without notice. Printed in the U.S.A.