

The Effect of Hard Particle Wear on Diesel Injectors

Summary of Industry Cooperative Diesel Injector Hard Particle Wear Testing Conducted at Southwest Research Institute (SwRI)

Since the late 1990s, diesel engine fuel system and equipment manufacturers along with filter manufacturers have cooperated in research efforts at Southwest Research Institute (SwRI) to determine the level of filtration required to protect fuel system components from hard particle damage. During the last 15 years, fuel injection technology has changed dramatically to meet rapidly evolving emissions requirements.

This document summarizes the research used to identify filtration requirements and encompasses two series of testing. The first series was completed in 2000 on traditional unit injectors; the second was completed in 2011 on the latest high pressure common rail (HPCR) systems introduced to the market to meet the new, more stringent emissions requirements.

Unit Injector Wear Testing Completed in 2000

The first series of unit injector testing consisted of running very narrow particle size distribution samples of dust at a concentration of 2-3 mg/l in low sulfur diesel through the injection systems. Degradation of performance was measured and unit injectors were inspected for damage. The hypothesis was that very fine dust would pass through without causing harm, and that larger particle size dust would begin to cause component wear. Testing was repeated with more typical representative fuel dust concentrations and size distributions in conjunction with various fuel filters to protect components. This was done

to identify the type of filters that are capable of preventing damage and performance degradation to the fuel injectors. Filters were tested in a single pass configuration in vibration on a diesel engine.

Unit injector performance degradation is determined by a decrease in fuel injection pressure. A measurement known as “push tube load loss” (PTLL) determines the decrease of in-cylinder fuel injection pressure. The decrease is caused by abrasive wear of the unit injector’s moving components and shows up as an increase in PTLL.

Exhibit 1 outlines “push tube load loss” in psi over 40 hours of run time, as unit injectors were exposed to fuel contaminated with various very narrow cuts of test dust and filtered fuel.

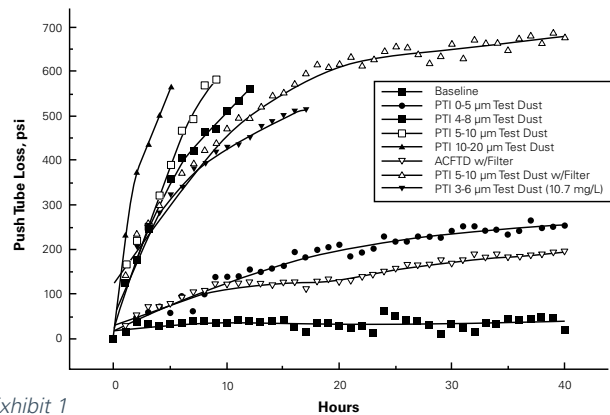

Exhibit 1

The **Baseline** (black squares across the bottom line ■), run with completely clean fuel, shows no increase in push tube load loss over the run time of the test.

The **PTI 0-5 µm Test Dust** (black circles ●) caused at most a modest increase in push tube load loss.

The **PTI 4-8 µm Test Dust** (black squares ■) caused a dramatic increase in push tube load loss almost immediately.

The **PTI 5-10 μm Test Dust** (white squares \square) also caused a dramatic increase in push tube load loss.

The **PTI 10-20 μm Test Dust** (black triangles \blacktriangle) caused the most dramatic increase in push tube load loss.

The **ACFTD** (AC fine test dust) with Filter (upside down white triangle ∇), is an example of contaminated fuel with a filter of sufficient efficiency to protect the injector from damage over the course of the test.

The **PTI 5-10 μm Test Dust w/ Filter** (white triangle Δ), is an example of a cut of dust that did damage without filtration and again did damage with a filter of insufficient efficiency in place that failed to protect the unit injectors.

The **PTI 3-6 μm Test Dust** (10.7mg/l) is a sample with a contamination levels on the high end of average for real world fuel and is shown to do rapid, severe damage to the injectors.

Based on this data, it was determined that particulate 6-7 μm and larger was likely to cause significant “push tube load loss”, due to abrasive wear. This correlates to a decrease in fuel injection pressure.

Additional Important Facts Learned in the Unit Injector Wear Testing

- Filters tested per traditional multi-pass standards have varying performance in on engine application. Test methods used in this research were able to identify performance differences in on-engine application for filters that were essentially identical in standard multi-pass testing.
- Work was also done to assess the role of fuel degradation in filtration performance. Aged or thermally stressed fuel produces soft sticky solid breakdown products that form in the liquid and can be captured by filters. The loading of this material in filter media tended to improve other hard particle retention to some degree.

High Pressure Common Rail (HPCR) Injector Wear Testing Completed in 2011

A second series of testing was done by many of the same participating manufacturers due to the emergence of new HPCR injection systems that operate at much higher pressures than previous Unit Injector systems. The higher pressures and tighter tolerances were expected to require significantly finer filtration media to protect injector systems.

Testing Approach

A similar approach to the earlier series of testing was used to assess dust sensitivity and filtration needs. A range of very narrow cuts of dust were prepared and run through operating fuel injection systems. During and after testing, various performance parameters and mechanical inspections were done to examine damage and in-system component behavior.

A test bench was built to:

- operate 6 common rail fuel injectors at 24,650 psi
- measure fuel cleanliness before and after filtration
- feed test dust and evaluate filters in vibration and flow related to the real world conditions.

A 50HP electric motor with a pump at 1,400 RPM ran the injector system with fuel temperature in operation at 86°F.

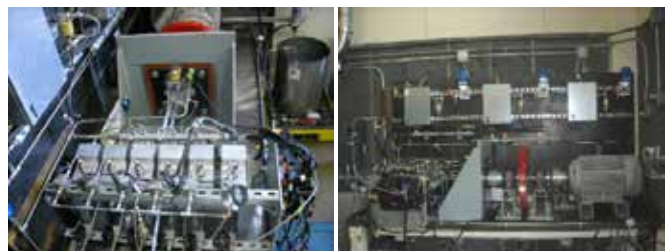

Test bench with 6 common rail fuel injectors at 24,650 psi.

Electric motor and pump injector system test bench.

Fuel in the test stand was Ultra Low Sulfur Diesel (ULSD). Lubricity was tested and verified to be within the American Society for Testing and Material (ASTM) standard D6079 for HFRR wear scar limit $<460 \mu\text{m}$ to ensure it was not contributing to wear in the system. Fuel conductivity was also measured and noted to be about 300 pS/m to ensure it was within specification over the course of testing.

At the time this series of tests was conducted, liquid particle counters were not certifiable per the International Organization for Standardization (ISO) 4406:1999 standard to discern particle size and distribution in the range that was of greatest concern for the HPCR systems (below 4 μm). Thus, another means of determining particle size was required. Testing was to be conducted with known distributions and concentrations of test dust. The dust manufacturer provided dry particle size results for each cut of dust so the expected result was known for any given dust sample and could therefore confirm the accuracy of another test method. This allowed for establishing an alternate particle sizing method by understanding if the new technique was producing results that could be related to prepared concentrations and distributions of particulate in a liquid. This alternate technique used an optical microscope capable of scanning a dust loaded filter patch (dust filtered from a known volume of fuel). The images were analyzed with software that counts the number and discerns the sizes of particulate. The count from the microscope, along with the known volume of filtered fluid, can be used to derive a dust concentration and distribution in a sample of fuel from the test stand.

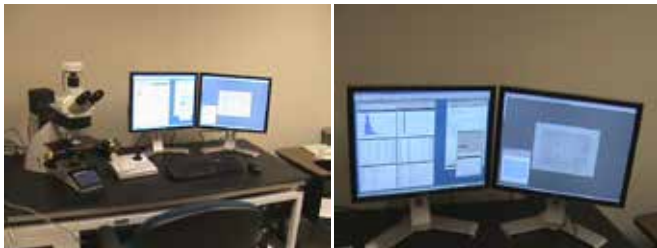

Digital Optical microscope system for scanning dust particulates.

This method is essentially a controlled, automated version of the ISO 4406 dust loaded filter manual/optical hard particle size concentration and distribution determination. However, the scope and software were able to accurately produce size and distribution results down below 4 μm to sizes as small as 0.8 μm . This ability was crucial for this round of injector wear testing because particles in this size range were theorized to be of concern for the new HPCR systems. Exhibit 2 shows an example of analysis for one of the cuts of test dust referred to as 0.8 μm to 2.5 μm dust. This technique was also used in this series of testing to evaluate post filter fluid samples to understand what size particulate may have passed through the filter and contributed to damage.

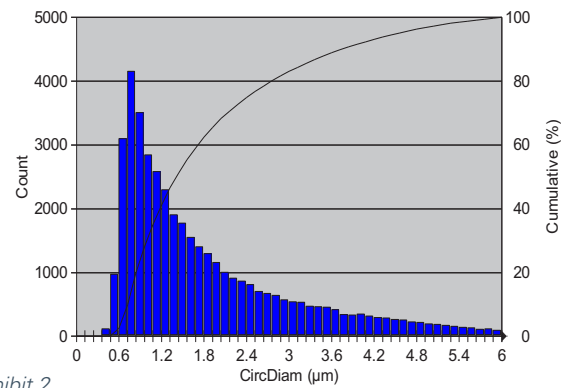

Exhibit 2

Note: The distribution is not exactly 0.8-2.5 μm , but is very narrow in comparison to typical test dusts and real world distributions that range from 0.7 μm to 85 μm with the vast majority of particles at a size less than about 15 μm .

Three separate samples of narrow cuts of test dust were used to test potential damage to the new HPCR injector systems. The cuts of dust included 0.8-2.5 μm , 2-6 μm , and 1.5-3.5 μm .

Baseline Testing With Clean Fuel

Before introduction of test dust, the test bench with a new set of 6 HPCR injectors was run with clean fuel for approximately 20 hours to assess break-in wear and note any changes in system operation parameters. The critical parameters for the HPCR systems are fuel flow to the engine and bypass flow from the injectors back to the fuel tank. An increase in bypass flow correlates to injector seal surface damage and results in poorly controlled fuel flow out of the injector tip into the cylinder. HPCR injectors typically do not wear at the injector tip, but in the 3-way valve section shown in the illustration below. This portion of the injector has very tight flow paths with tolerances in the range of 2-3 μm . Fuel is controlled at very high pressures (24,650 psi in this case).

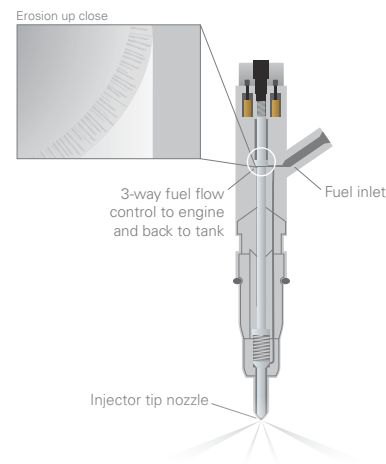

Scanning Electron Microscope (SEM) images were taken of the upper and lower valve surface after disassembly to evaluate their condition and correlate with the fuel flow data collected during the system run.

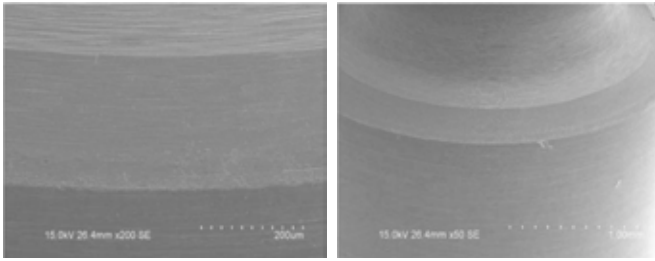

SEM: 0.8 -2.5 μm highest leakage upper valve seat at 200X magnification on left and 50X on the right.

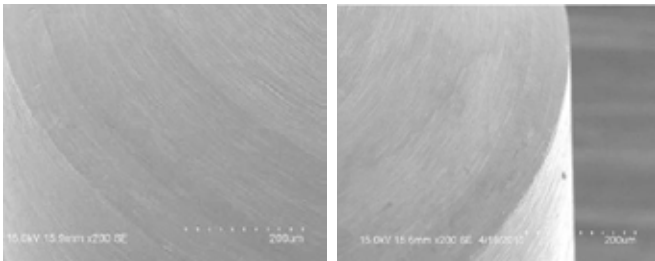

SEM: 0.8 -2.5 μm highest leakage lower valve seat at 200X magnification.

The valve seat images above show only a few extremely mild signs of wear from particulate after testing on the 0.8-2.5 μm dust loaded fuel. There are some very minor particle indentations along the upper valve seat, and the lower valve housing shows only break in wear and original machining marks.

Exhibit 3 shows fuel injector flow rates to the engine (FLO_ENG) and flow back to the fuel tank (BFLO_ENG) over time during the break in base line test on ULSD.

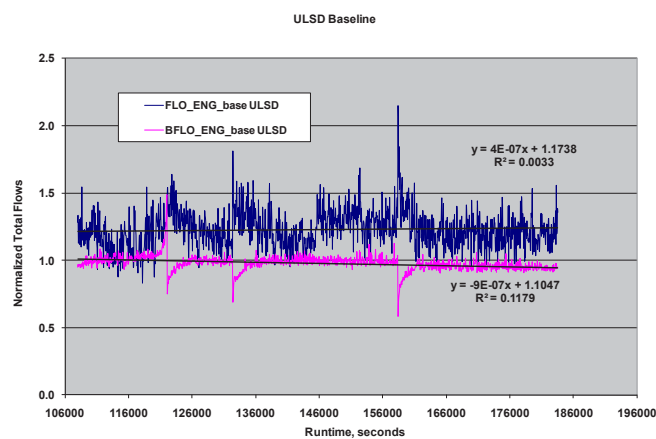

Exhibit 3

Note that the flow rates are staying essentially stable and parallel over time. This is the expected behavior for injector flow performance on fuel that does not contain sufficient hard particulate to cause damage. The 3 corresponding peaks over the course of this test are start-up condition related. The test bench was not run continuously, but stopped overnight and testing resumed again the next day. Once the base line performance and behavior were established on pristine clean fuel, the introduction of known cuts and concentrations of test dust into the fuel system could be done to assess damage.

0.8-2.5 μm Test Dust Without Filtration

A new set of injectors was run on clean fuel for 20 hours for break in prior to the introduction of 0.8-2.5 μm test dust. The test dust was blended into the fuel to a level of approximately 1 mg/l. This is a typical concentration of dust in grams, but is much finer than what is found in real world fuel. A fuel ISO cleanliness of 18/16/13 is on the cleaner side of average in real world situations. This fuel with the 0.8-2.5 μm test dust in it would not have an ISO count to describe the fuel's hard particulate contamination, because all of the particulate is smaller than 4 μm . The minimum size particulate accounted for in the ISO 4406:1999 standard method for coding the level of contamination by solid particles is 4 μm .

The system with 0.8-2.5 μm dust-contaminated fuel was run for 41 hours, disassembled and inspected for damage. Data from the run shown in Exhibit 4 indicates that there was little to no change in flow of fuel to the injector or bypass flow back to the tank.

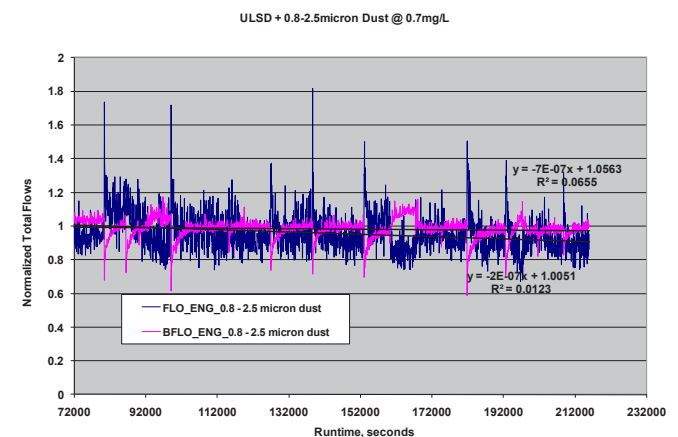
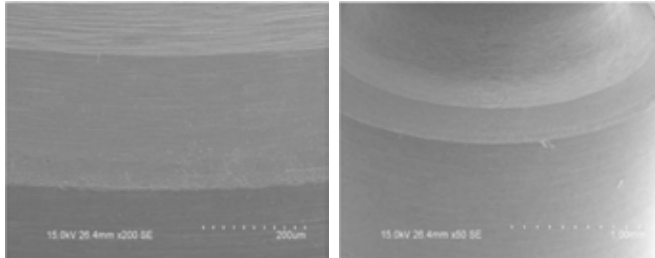

Exhibit 4

This indicates that the majority of particles in the 0.8-2.5 μm contaminated fuel are not likely to be a concern for the HPCR fuel system components. This correlates nicely with the SEM images of the highest leakage valve seats.

Scanning Electron Microscope (SEM) images were taken of the valve upper and lower valve surfaces after disassembly to evaluate their condition first hand and correlate with the fuel flow data collected during the system run.



SEM: 0.8 -2.5 μm highest leakage upper valve seat at 200X magnification on the left and 50X on the right.

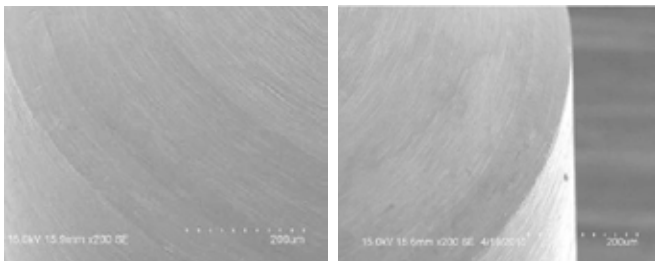

SEM: 0.8 -2.5 μm highest leakage lower valve seat at 200X magnification.

The above valve seat images above show only a few extremely mild signs of wear from particulate after testing on the 0.8-2.5 μm dust loaded fuel. There are some very minor particle indentations along the upper valve seat, the lower valve housing shows only break in wear and original machining marks.

2-6 μm Test Dust Without Filtration

Another new set of injectors was installed and run through the 22 hour break-in on clean fuel prior to the addition of 2-6 μm test dust. Dust was again added to the fuel at a concentration of 1mg/l.

The system with 2-6 μm dust contaminated fuel was run for 41 hours, disassembled and inspected for damage. Data from the run shown in Exhibit 5 indicates that there was an immediate change in flow of fuel to the injector or bypass flow back to the tank. This change continued over the entire test run. This indicates that damage is being done to the HPCR system.

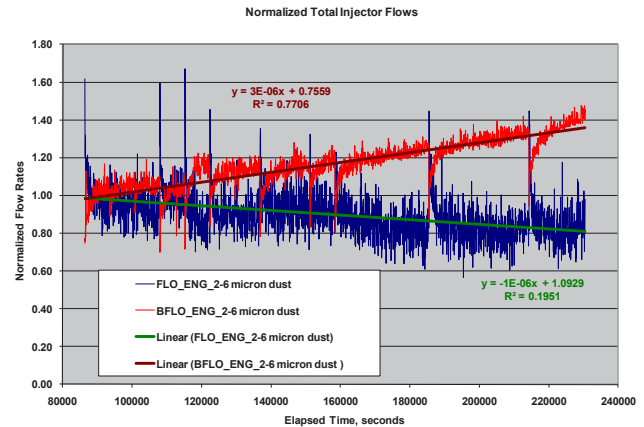
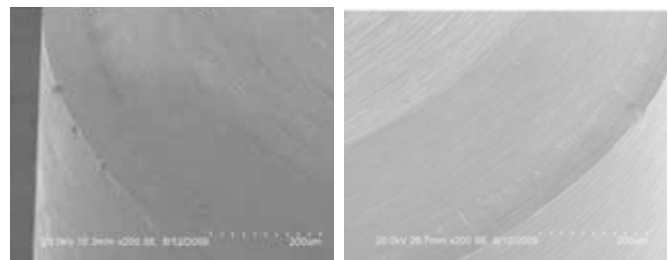

Exhibit 5

As seen in Exhibit 5, the constant increase in back to tank flow (BFLO_ENG_2-6 micron dust) in this case started immediately and continued for roughly 41 hours. This behavior tends to correlate with injector seat damage.

In the upper seat images, particle indentations can be seen having formed as the surfaces come together with particles present between them causing initial damage. There is the beginning indications of erosion, visible as a thin, straight line across the sealing surface. In the lower seat image on the right, the development of a significant



SEM: 2 -6 μm highest leakage Lower/ Upper valve seat both at 200X magnification.

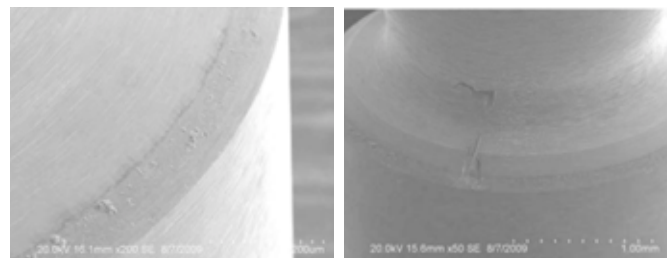

SEM: 2 -6 μm lowest leakage lower valve seat at 200X on the left and 50X magnification on the right.

erosion channel can be seen. This is caused by the flow of high pressure liquid containing particulate beginning to pass from one side of the seal to the other, even when closed; thus eroding the channel as flow continues. These channels develop when the small, round impact indentations formed when particles are initially trapped between the mating surfaces, increase in number to the point that they connect together and flow begins passing through the damage channels.

1.5-3.5 µm Test Dust Without Filtration

A new set of injectors was installed and run through the 22 hour break-in on clean fuel prior to the addition of 1.5-3.5 µm test dust. Dust was again added to the fuel at a concentration of 1 mg/l.

As shown in Exhibit 6, the constant increase in back to tank flow (BFLO_ENG_1.5-3.5 micron dust) started immediately and continued as the system continues operation for roughly 41 hours.

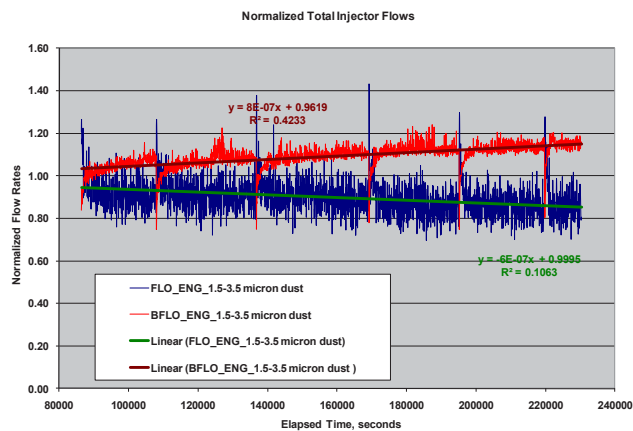
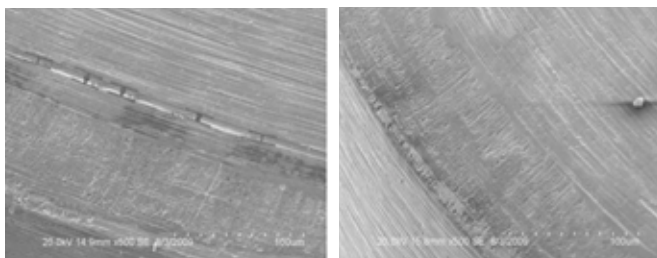
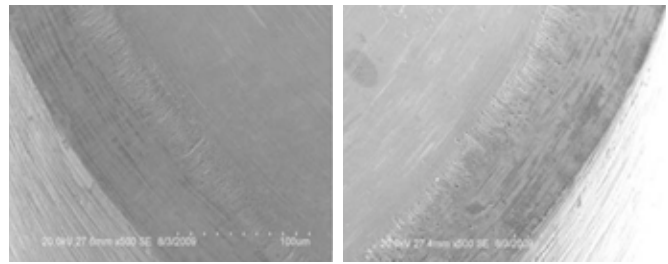

Exhibit 6

In both the lower and upper seat images a high number of indentations can be seen that are caused by hard particles being present as the seal faces close. On the upper seat images the beginnings of erosion channels are visible. The lower seal faces also show small indentations beginning to connect due to erosion.



SEM: 1.5 -3.5 µm lowest leakage lower valve seat both at 500X magnification.



SEM: 1.5 -3.5 µm highest leakage upper valve seat at 500X magnification.

The 0.8-2.5 µm dust did very little damage, likely because it was small enough to pass through without causing the indentations that lead to erosion. The 2-6 µm dust did cause indentation damage. The 1.3-3.5 µm dust caused extensive indentations. Therefore, it was concluded that particulate in the range of 2-3 µm was of most concern for causing indentations and eventually catastrophic erosive wear in the HPCR system.

Validation of Filtration Protection

After establishing a basic understanding of the sensitivity to particulate size based on the test results described above, further testing was initiated to evaluate filtration performance and protection of the HPCR injection system. A more typical real world fuel test dust distribution of ISO 12103 A1 ultra-fine 0-10 µm test dust was used for filter evaluation. The dust was also dosed at a higher level than in the un-filtered narrow cut of dust trials at 1 mg/l. In the filtration evaluation trials a dust load of 5 mg/l was used. This concentration is on the high end of average for dust contamination in real world fuel applications. Before each filtration trial, the wear components in the injectors were replaced followed by a 2 hour break-in run on clean fuel to establish baseline performance and ensure no mechanical issues. The target run time for each filtration trial was 80 hours. If fuel flow back to tank exceeded the maximum allowed or the filter plugged, the trial would be terminated early.

In addition to the injector fuel flows and SEM images of the injector valve seats to assess damage, the filtration testing also monitored the ISO 4406 code for particulate 4 µm and larger and 6 µm and larger, producing a somewhat unconventional 2 ISO code number reporting a $\geq 4 \mu\text{m}/\geq 6 \mu\text{m}$ number of the fuel downstream on the filter in the system. In these tests, since ISO ultrafine test dust with particulate sized from 1-10 µm was used,

there are no 14 µm and larger particles to report. A 5 mg/L concentration of ISO ultra-fine dust produces a 2 ISO code number of approximately 22/21. A controlled volume of fuel flowing downstream of the filter was passed through a filter patch to produce a distribution and density of particles that would then be evaluated by the optical microscope method outlined earlier in the report. This technique allowed for the production of a fuel ISO cleanliness assessment, percent removal efficiency at 1-10 micron sizes over time and an ability to estimate total particles passed through the injectors over the course of the test.

Filter Test #1

Filter test #1 was conducted with a current technology (2009), high efficiency fuel filter that was later found to have a known minor manufacturing issue.

Exhibit 7 depicts filtration efficiency at each µm size over the duration of test #1. The filter starts at a very low efficiency, then increases quickly to about 75%, only to drop off significantly and then reach an efficiency again of about 65% before the test run ended at about 37 hours due to excessive leakage back to tank.

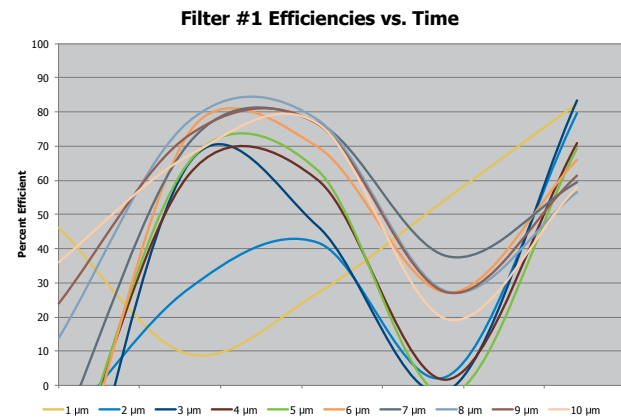

Exhibit 7

It is important to note that in Exhibit 7 the general efficiency begins to crash around 30 hours for all µm sizes.

Exhibit 8 below shows the injector flow rate data. Around 30 hours, the normalized total injection leakage flowing back to tank increases dramatically. As noted before, this tends to correlate directly to particulate damage, first indentations and then erosion of the injector seat surfaces.

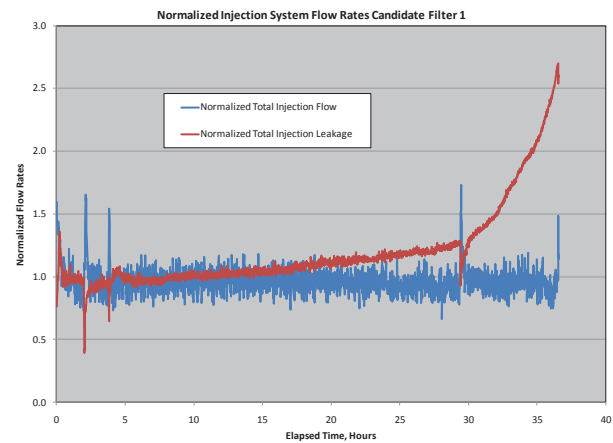
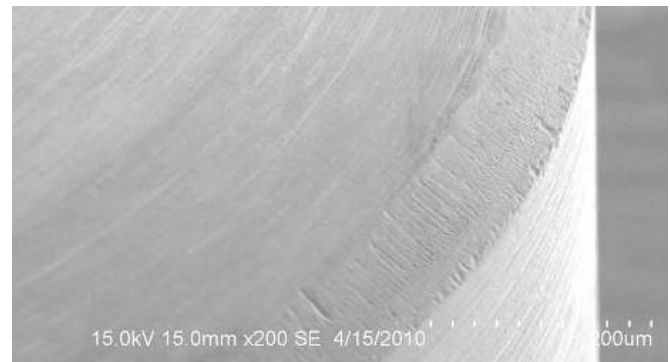

Exhibit 8

In this case, the injector failed at 37 hours and testing was terminated. The average 2 digit $\geq 4 \mu\text{m}/\geq 6 \mu\text{m}$ ISO code determined by optical patch counting method for this test was ISO 20/20 to 19/19. This is perhaps a 1-2 ISO code drop from the pre-filter concentration, indicating the filter was not removing nearly enough material to protect the injectors.

The SEM images of the injectors show severe damage from hard particulate.



SEM: Test #1 lowest leakage lower valve seat at 200X magnification.

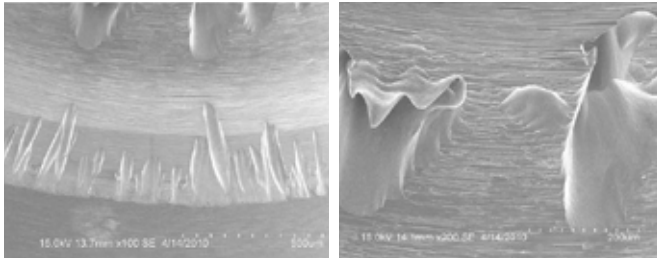

SEM: Test #1 highest leakage lower valve seat at 100X on left and 200X on right.

Note the severe erosive channels on the sealing surfaces from hard particulate in the fuel at high pressures cutting the surface. These erosion channels are created after minor indentations initially form and begin to connect together, establishing a leak path that erodes severely if particulate continue to pass through the system.

Filter Test #2

Filter test #2 was conducted with a large filter element to reduce face velocity.

In Exhibit 9, the graph depicting filtration efficiency at each μm size over the duration of test #2. The filter starts at approximately 80% efficiency, decreases quickly to 20-40%, only to recover and then slowly drop off until the end of the test run at 80 hours. The filter produced 2 digit $\geq 4 \mu\text{m}/\geq 6 \mu\text{m}$ ISO cleanliness downstream of the filter ranging from ISO 18/17 to 20/18.

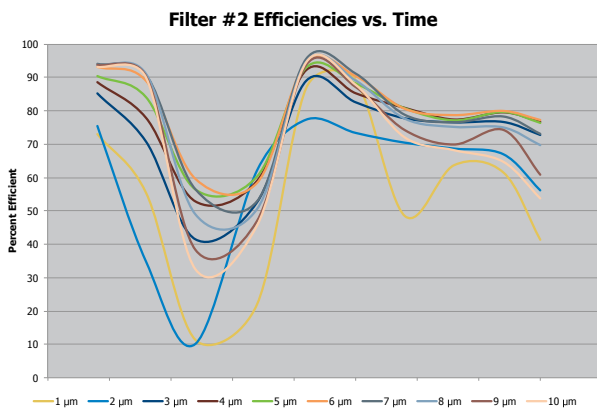

Exhibit 9

Overall, the filter had an efficiency in the 70% range throughout the 80 hour test. The test was run to completion, because the injector leakage back to tank did not increase to a point that the fuel system would fail. In the injector data Exhibit 10, there appears to be at least a slight correlation with the efficiency data in Exhibit 9 in that the normalized injector leakage back to tank changes when the efficiency does. However, there is no telltale spike in leakage at catastrophic failure, only evidence of hard particle impacts on the seat surfaces, which indicates that damage has occurred but erosion has not yet developed extensively.

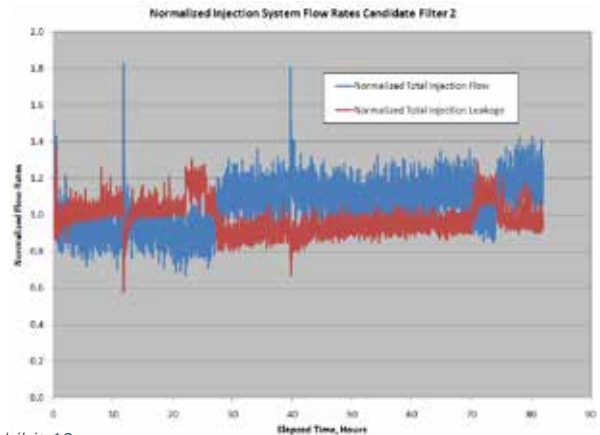
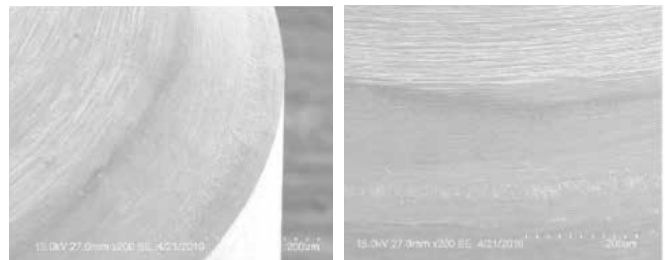

Exhibit 10

This test ran to completion and injectors were disassembled for inspection and SEM imaging.



SEM: Test #2 highest leakage upper valve seat at 200X magnification.

The highest leakage lower valve seat had one extreme channel of erosion (not pictured) and pitting at the seal faces. This is similar to the initial damage seen in the shorter duration narrow cuts of dust testing done as

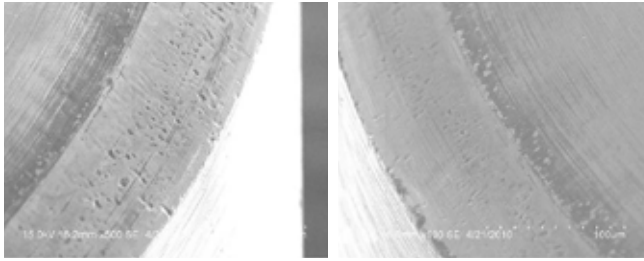

SEM: Filter test #2 highest leakage lower valve seat at 500X magnification.

preliminary work in the project. A continuation of this level of contamination would likely lead to numerous erosion channels across the seal surfaces and catastrophic failure. It is not known if this damage occurred as a one-time incident around the 30 hour mark or was ongoing due to the average efficiency over the 80 hour test.

Filter Test #3

Filter #3 was conducted with a current technology (circa 2009) filter with no manufacturing issues.

Exhibit 11 depicts filtration efficiency at each μm size over the duration of test #3. This filter starts at approximately 80% efficiency, then decreases quickly to about 45% only to recover and sharply drop off repeatedly and more severely over the course of the test. The test ran the full 80 hours. The filter produced 2 digit $\geq 4 \mu\text{m}/\geq 6 \mu\text{m}$ ISO cleanliness codes downstream of the filter ranging from ISO 12/12 to 15/15. The filter had excursions of efficiency at times that appear to allow more particles downstream than are entering into the filter, thereby creating negative efficiency on some particle sizes for some periods during the test.

Filter #3 Efficiency vs. Time

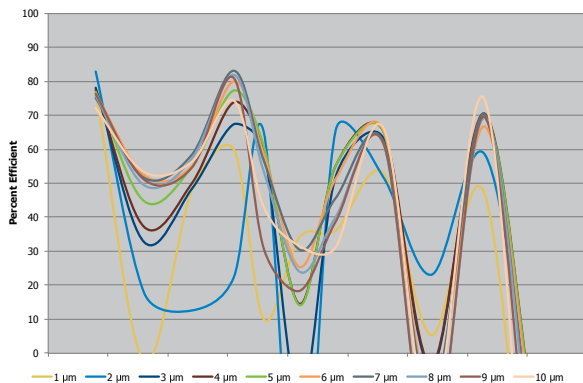

Exhibit 11

The decreases in efficiency seem worsen over time as the test progressed. The overall efficiency of the filter over the course of the test was in the 50% range.

Exhibit 12 shows data on injector flow to cylinder and leakage back to tank. The injector leakage was increasing over the course of the test, but did not spike dramatically towards failure until very late in the 80 hour test.

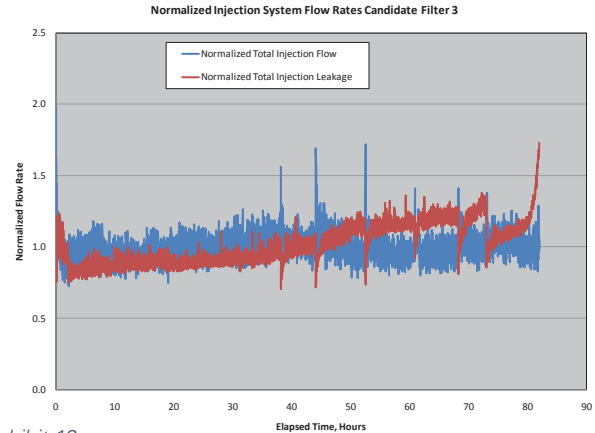
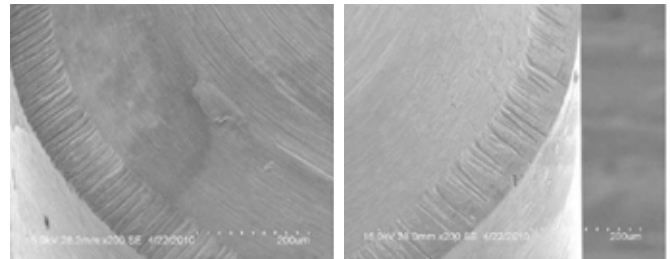
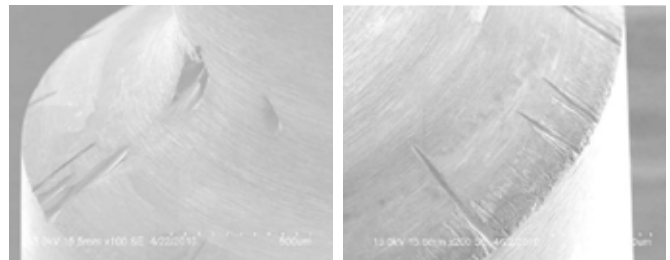

Exhibit 12

Test #3 injectors were disassembled and inspected for damage using SEM imaging. Damage to injectors included significant erosion across the upper valve extending the width of the seat and extensive erosion on the lower valve seat and into the valve stem.



SEM: Highest leakage upper valve seat 200X magnification.



SEM: Highest Leakage lower valve seat 100X magnification on left and 200X magnification on right.

As shown above, significant damage has been done to the seats in the injectors, and their ability to function properly is compromised.

Filter Test #4

Filter test #4 utilized a series fuel filter set up with 2 of the same filters in series.

Exhibit 13 depicts filtration efficiency at each μm size over the duration of test #4. This filter runs at approximately 85% efficiency over the course of the test. The test run lasted the full 80 hours. The filter produced 2 digit $\geq 4 \mu\text{m}/\geq 6 \mu\text{m}$ ISO cleanliness codes downstream of the filter ranging from ISO 12/12 to 11/11. The filter had only a modest excursion of efficiency at about 50 hours, but recovered.

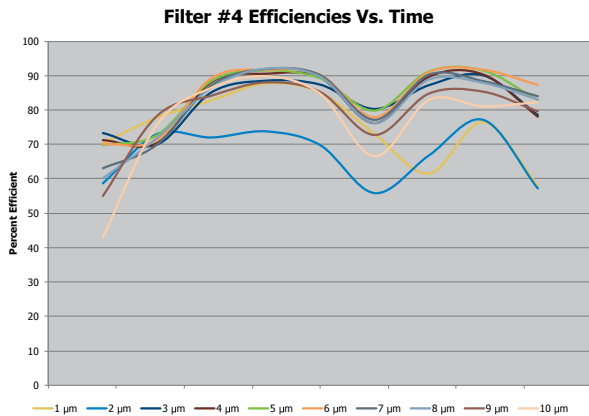

Exhibit 13

As seen in Exhibit 13, the filter system performed well and consistently compared to the previous examples with no large excursions to low efficiency. This should correlate to good protection of the fuel injection system preventing an increase in leakage back to tank.

Exhibit 14 shows data on injector flow to cylinder and leakage back to tank. As shown, the injector leakage did not change significantly over time in the 80 hour test.

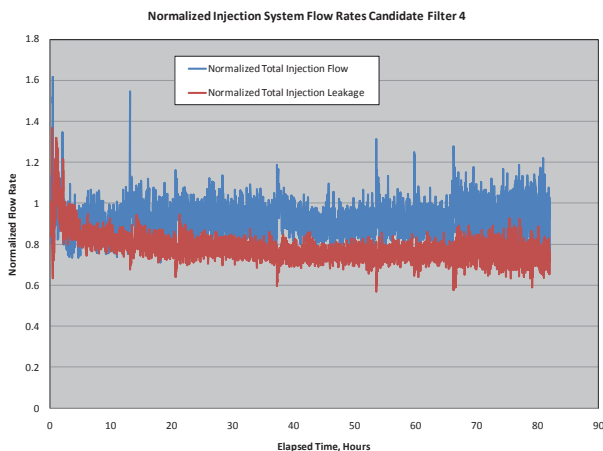
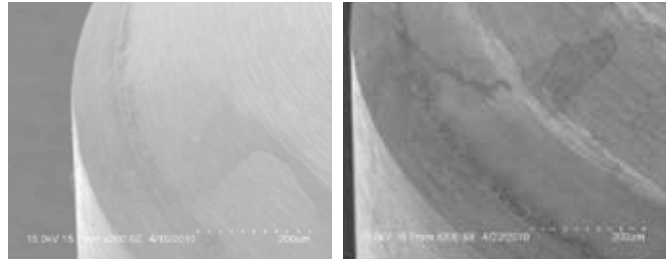
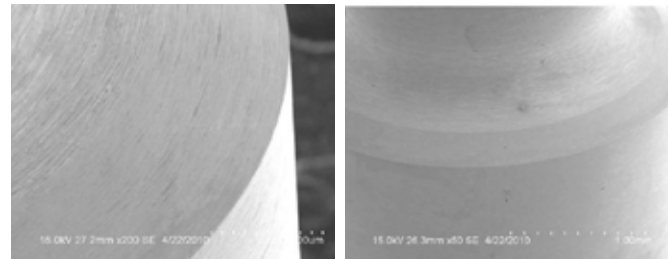

Exhibit 14

The lack of change in leakage should correlate to minimal injector seat damage in the SEM analysis. In the SEM images below there is little more than breaking wear on seal surfaces.



SEM: Lowest (left) and highest (right) leakage lower valve seats at 200X magnification.



SEM: Highest leakage upper valve seat images at 200X magnification left and 50X magnification right.

As seen in the images above, there are only a few hard particle impacts at the seal interface and no evidence of any erosive wear in the system. This example shows no degradation similar to the first three filtration tests with indentations due to seal faces closing, particles being present and then erosion across the seal faces as the indentations connect and allow leakage.

Filtration Test #5

Filter test #5 utilized a large fuel filter to reduce face velocity.

The graph in Exhibit 15 depicts filtration efficiency at each μm size over the duration of test #5. This filter runs at approximately 95% efficiency over the course of the test.

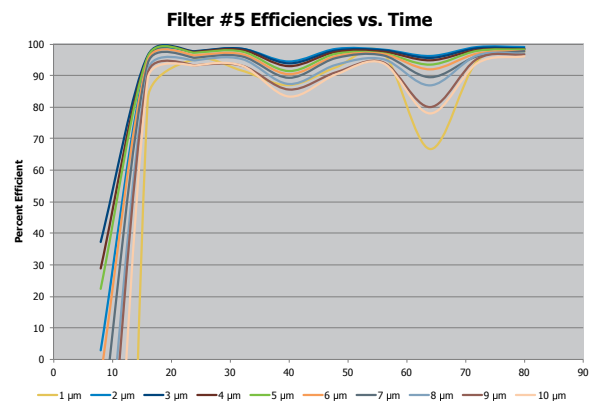

Exhibit 15

The test run lasted the full 80 hours. The filter produced 2 digit $\geq 4 \mu\text{m}/\geq 6 \mu\text{m}$ ISO cleanliness codes downstream of the filter ranging from ISO 10/10 to 13/12. The filter had only a modest excursion of efficiency at about 65 hours but recovered. The initial efficiency measurement appears very low, but the filter quickly increased to approximately 95% efficiency for the duration, suggesting there may have been some contamination in the bench at test start.

The single large filter performed well and consistently compared to the first three examples with no large excursions to low efficiency other than the low efficiency initial data point. The filter ran the remaining duration of the test with efficiency higher than that of the fourth test. This, too, should correlate to good protection of the fuel injection system and prevention of an increase in leakage back to tank.

Exhibit 16 shows the data on injector flow to cylinder and leakage back to tank. As shown, the injector leakage did not change significantly over time in the 80 hour test.

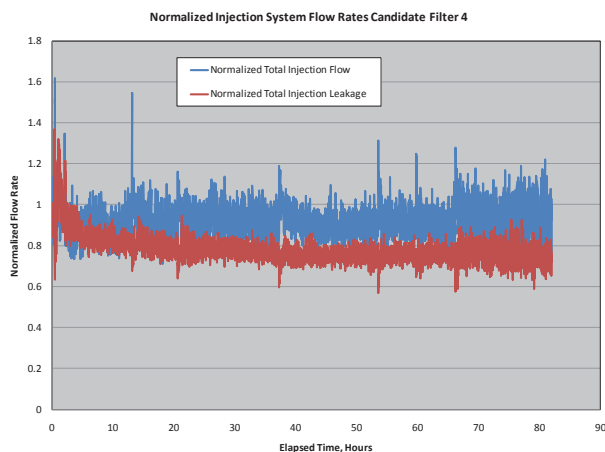
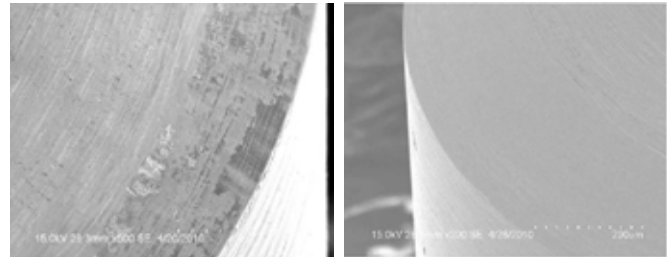

Exhibit 16

It is theorized that the initial debris load identified in the efficiency data correlates to the early initial change in leakage. The system ran consistently for the remainder of the test. A mechanical integrity filter issue or lack of actual filtration efficiency are unlikely causes for this result considering the high efficiency performance during the

remainder of the test. It seems most likely that as the test started, a source of debris was entrained in the fuel beyond the filter. Because any damage did not seem to progress over time, and because the filter continued to remove most of the introduced dust, it appears the filter was functioning properly over the course of the test.

The SEM images below show very little damage other than a possible large impact from a very large, hard particle.



SEM: Lowest leakage Upper Valve Seat 500X magnification left and highest right at 200X magnification.

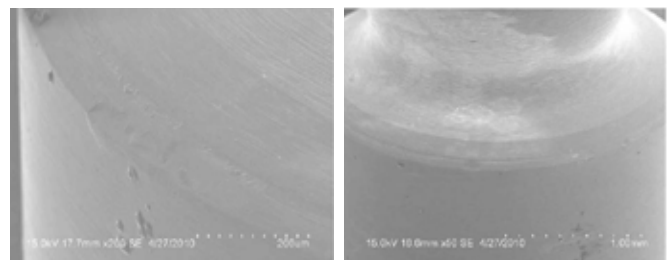

SEM: Highest Leakage lower valve seat 200X magnification left and 50X magnification right showing the large indentation on the edge.

Note that the large indentation on the edge of the surface looks nothing like other damage on the test injectors in the rest of this report. This example also shows no degradation similar to the first 3 filtration tests with indentations due to seal faces closing with particles being present followed by erosion across the seal faces as indentations connect and allow leakage.

Fuel Cleanliness Summary

In Exhibit 17, the graph depicts the average number of particles per minute counted after the filter. This correlates to the average ISO cleanliness of fuel downstream of the filter over the course of the test. The ISO codes were noted above in each case.

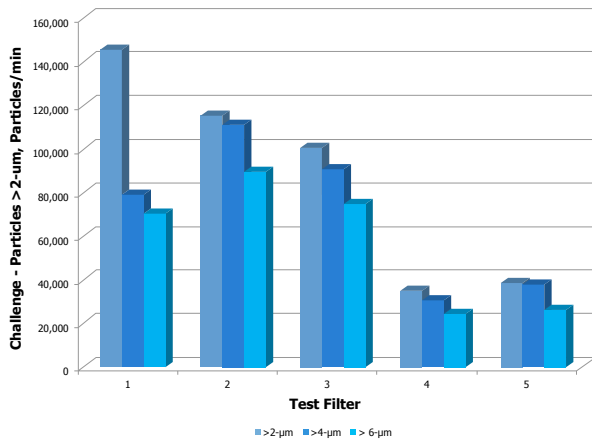

Exhibit 17

There is a notable difference between filters 1-3 and filters 4-5. Filters 1-3 have relatively high average counts compared to filters 4 and 5 with much lower counts. This difference correlates strongly with the damage seen in the HPCR injectors analyzed for each filtration test and the wear particle tests established without filtration.

Conclusion

This testing established:

- Particulate in the range of 2-3 μm produced mechanical damage in a 24,650 psi HPCR system.
- A different type of damage and wear occurred in the HPCR systems compared to lower pressure systems (abrasive wear). Initial impact wear, or indentation, occurs on the seal face. As that damage accumulates, severe erosive wear occurs due to the high pressure leakage of fuel that contains particulate passing across the sealing face when closed.
- Filter integrity and consistent, high-efficiency performance is essential to protect modern HPCR injection systems.
- This test method allowed the differentiation between filters that can protect HPCR injectors from damage in testing from those that cannot. Test filters 4 and 5 did protect the injectors while test filters 1, 2 and 3 did not.

About Southwest Research Institute

Southwest Research Institute (SwRI), headquartered in San Antonio, Texas, is one of the oldest and largest independent, nonprofit, applied research and development (R&D) organizations in the United States. Founded in 1947, SwRI provides contract research and development services to industrial and government clients in the United States and abroad. The Institute is governed by a board of directors, which is advised by approximately 100 trustees.



Donaldson Company, Inc.
Minneapolis, MN

MyCleanDiesel.com
donaldsonfilters.com

North America 800-374-1374
Mexico 52-449-910-6150
Latin Am. & Caribbean 52-449-910-6150
Brazil 55-11-2119-1604
Europe 32-16-38-3811

South Africa 27-11-997-6000
South East Asia 65-6311-7373
Greater China 852-2405-8388
Japan 81-42-540-4112
Korea 82-2-517-3333
Australia 61-02-4350-2033
India 91-124-2290060

Brochure No. F111422 ENG (2/15)

© 2015 Donaldson Company, Inc. All rights reserved. Donaldson Company, Inc. reserves the right to change or discontinue any model or specification at any time and without notice. Printed in the U.S.A.